

Working with Stainless Steels

by Pierre-Jean CUNAT

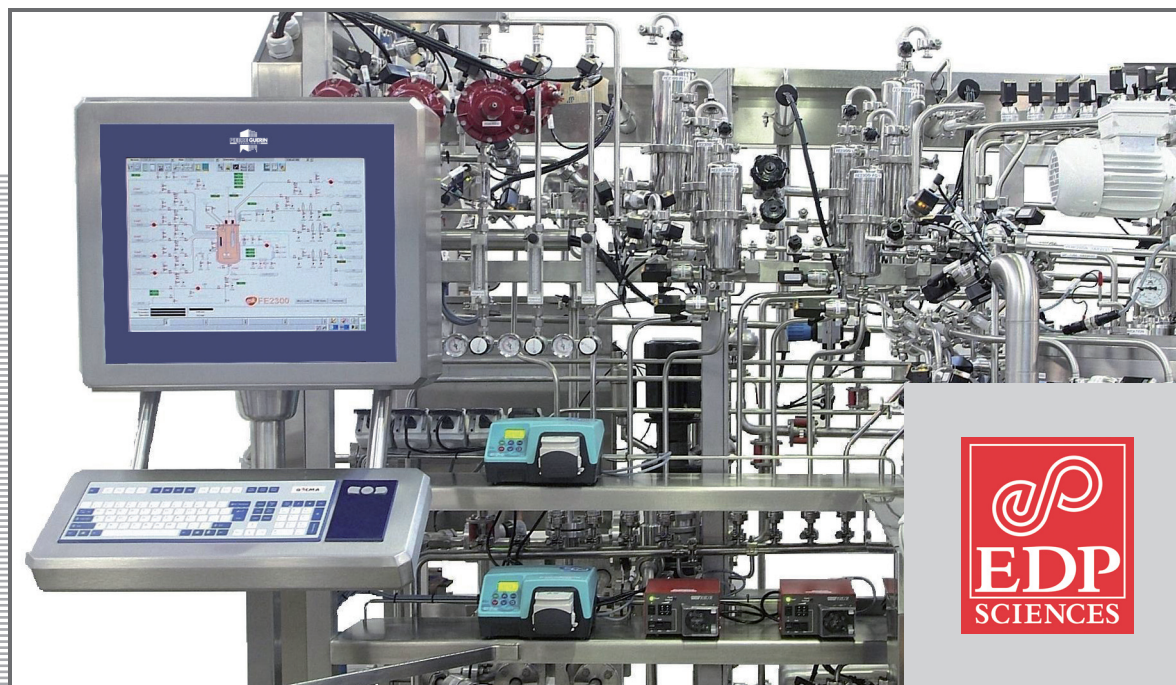

Euro Inox

Euro Inox is the European market development association for stainless steel.

Members of Euro Inox include:

- European stainless steel producers
- national stainless steel development associations
- development associations of the alloying element industries

The prime objectives of Euro Inox are to create awareness of the unique properties of stainless steel and to further its use in existing applications and in new markets.

To achieve these objectives, Euro Inox organises conferences and seminars, issues guidance in printed and electronic form to enable architects, designers, specifiers, fabricators and end users to become more familiar with the material. Euro Inox also supports technical and market research.

Copyright notice

This work is subject to copyright. Euro Inox reserves all rights of translation in any language, reprinting, re-use of illustrations, recitation and broadcasting. No part of this publication may be reproduced, stored in a retrieval system or transmitted in any form or by any means, electronic, mechanical, photocopying, recording or otherwise, without the prior written permission of the copyright owner, Euro-Inox, Luxembourg. Violations may be subject to legal proceedings, involving monetary damages as well as compensation for costs and legal fees, under the French and/or Luxembourg copyright law.

Pierre-Jean CUNAT is hereby identified as the author of this work in accordance with the “code la propriété intellectuelle” (the French copyright law) of March 11, 1957, July 3, 1985 and followings: Art. L121-1 to L121-9, Art. L122-1 to L122-12, Art. L123-1 to L123-12.

Full members

Acciai Speciali Terni
www.acciaiterni.it

Acerinox
www.acerinox.com

Aperam
www.aperam.com

Outokumpu
www.outokumpu.com

Associated members

Acroni
www.acroni.si

British Stainless Steel Association (BSSA)
www.bssa.org.uk

Cedinox
www.cedinox.es

Centro Inox
www.centroinox.it

ConstruirAcier
www.construiracier.fr

Industeel
www.industeel.info

Informationsstelle Edelstahl Rostfrei
www.edelstahl-rostfrei.de

International Chromium Development Association (ICDA)
www.icdacr.com

International Molybdenum Association (IMOA)
www.imoa.info

Nickel Institute
www.nickelinstitute.org

Paslanmaz Çelik Derneği (PASDER)
www.turkpasder.com

Polska Unia Dystrybutorów Stali (PUDS)
www.puds.pl

Stowarzyszenie Stal Nierdzewna
www.stalenierdzewne.pl

SWISS INOX
www.swissinox.ch

Working with stainless steels
Second edition, 2008
ISBN Euro Inox 978-2-87997-181-0
ISBN EDP Sciences 978-2-7598-0375-0
Published by EDP Sciences and Euro Inox
© EDP Sciences and Euro Inox 2008
First published as “Travailler les aciers inoxydables”,
ISBN 2-906643-15-7 © SIRPE 1998, Paris.
English Translation “Working with Stainless Steels”
ISBN 2-906843-16-5 © SIRPE 1998, Paris

Publishers

EDP Sciences
17 avenue du Hoggar
P.A. de Courtaboeuf
BP112
91944 Les Ulis Cedex A
France
Tel.: +33 1 69 18 17 62 / Fax +33 1 69 86 07 65
www.edpsciences.org
Euro Inox
Registered office:
241 route d’Arlon
1150 Luxembourg, Grand Duchy of Luxembourg
Tel.: +352 26 10 30 50 / Fax: + 352 26 10 30 51
Executive office:
Diamant Building, Bd. A. Reyers 80
1030 Brussels, Belgium
Tel.: +32 2 706 82 67 / Fax: +32 2 706 82 69
E-mail: info@euro-inox.org
Internet: www.euro-inox.org

Author

Written and coordinated by Pierre-Jean Cunat, Joinville-
le-Pont (France),
with support from
“Compagnons du Devoir du Tour de France”
Translated from French by James H. Davidson
B Met, Ph D (†)

Contents

Preface
Foreword
1. The stainless Steels
1.1 The forms of corrosion
1.2 The stainless steel family
1.3 Choice of a stainless grade
1.4 Heat treatment
1.5 Commercially available stainless steel products
2. Working with stainless steels
2.1 Cutting – Thermal cutting
2.2 Machining
2.3 Cold forming
2.4 Hot forming
3. Joining operations
3.1 Welding
3.2 Brazing and soldering
3.3 Adhesive bonding
3.4 Mechanical joining
4. Surface condition
4.1 Characterisation of the surface
4.2 Surface preparation and treatments
5. Testing and inspection
5.1 Metallurgical testing and inspection
5.2 Mechanical testing
6. Appendices
6.1 Physical and chemical properties of stainless steels
6.2 Identification and designation of stainless steels
6.3 Index, acronyms and abbreviations
6.4 Reference list of illustrations and photo credits
6.4 Bibliographical references

Disclaimer

EDP Sciences and Euro Inox has made every effort to ensure that the information presented in this book is technically correct. However, the reader is advised that the material contained herein is for general information purposes only. EDP Sciences its referees and Euro Inox its members, specifically disclaim any liability or responsibility for loss, damage, or injury, resulting from the use of the information contained in this book.

Preface to the revised edition

There is no doubt that iron and the art of working it have played an essential role in man's dominance of nature and rise to power. It is generally considered that the Hittites and the Caucasian peoples known as the Chalybites knew how to extract iron from hematite as early as 1700 BC. However, cast iron, which is essentially an alloy of iron and carbon, did not appear before about 1300 AD, while the industrial production of steel really began to become important only in the XIXth century. Although steel is now well established and widely employed in heavy industry, there is still a lack of knowledge and expertise in its use in many small and medium sized enterprises (SMEs) and small workshops. It was in order to meet this need that the handbook *“Working with steel – a manual for craftsmen and technicians”* was published in 1998.

The history of stainless steels is much more recent, the first industrial developments dating to around 1910. The stainless steels have since then become well recognized for their exceptional corrosion resistance, their attractive appearance and the durability of their surface condition. Nevertheless, there remains a need for a better knowledge of not only the intrinsic properties of stainless steels, including their corrosion and oxidation resistance and high temperature mechanical strength, together with all the other characteristics necessary for their use as structural materials, but more particularly, of their capacity to be processed by various cold and hot forming techniques and different methods of joining.

As in the book already mentioned, *“Working with stainless steels”* aims to provide a general background knowledge of

these materials, together with the essential know-how necessary for their choice and implementation, and endeavors to present the information in a readily accessible and practical manner.

Finally, the publication would not have been possible without the expertise and enthusiasm of Roger Drouhin (†), general manager of the Société d'Ingénierie, de Recherche, de Prospective et d'Édition.

The manual *“Working with stainless steels”* is the result of this exemplary collaboration and will undoubtedly achieve the assigned objective.

Pierre-Jean CUNAT

Foreword

The early history of stainless steels is intimately related to that of chromium and to the work of the French chemist Nicolas Louis Vauquelin (1763–1829), which led to the discovery of this metal in 1797.

The first observations of the “stainless” properties of iron-chromium alloys were made by Berthier in 1821.

However, the earliest systematic studies on iron-chromium alloys were those of L. Guillet in France (1904) and W. Giesen in Germany (1909).

In 1909, Guillet published the results of work on Fe-Cr and Fe-Cr-Ni alloys, and classified them according to their structure as either martensitic (13% Cr), ferritic (17% Cr) or austenitic (18% Cr – 8% Ni).

These laboratory studies were not followed by industrial manufacture until after 1910.

The name of the English metallurgist from Sheffield, Harry Brearley, is associated with the first industrial production of martensitic stainless steels, in 1913.

In addition to the people already mentioned, it is now recognized that among the major works carried out between 1900 and 1915 on what were to become the stainless steels were those of A. Portevin (1903) in France, and P. Monnartz, B. Strauss and E. Maurer (1912) in Germany.

While many laboratory studies were performed during the period mentioned, it was not until almost half a century later that stainless steels were produced on a genuinely industrial scale. The major difficulty encountered in their development was the accurate control of certain alloying elements, particularly chromium and carbon.

From the late 1920's, different forms of stainless steel products were employed in architectural applications. One of the most famous of these is the roof of the Chrysler building in New York, which was constructed from sheets of 18% Cr – 9% Ni alloy manufactured in Europe.

Despite the aggressive New York atmosphere, which has a mixed urban and maritime character, the roof is still in perfect condition today, after almost eighty years service.

Another example, dating back to the same period (1928–1930), is the system of bars used to reinforce the base of the dome in Saint Paul's cathedral in London, composed of a circular ring and truss rods linking the inside and outside surfaces. In this application, stainless steel was chosen both for its mechanical properties and for its corrosion resistance. As in the previous case, the material is still in perfect condition and continues to fully perform its function.

Among more impressive constructions, the Geode at the La Villette City of Science and Industry in Paris, built in 1985, is particularly noteworthy.

It is a 36 meter diameter sphere composed of 6433 triangles of 1.5 mm thick 17% Cr – 11,5% Ni – 2% Mo austenitic stainless steel sheet. In order to obtain the desired effect, a “mirror polish” surface condition was employed, giving the finished building an absolutely remarkable reflectivity.

Finally, the Brussels based Atomium – built in 1958 – underwent a complete refurbishment of its outer skin during 2005. This time, 1.2 mm stainless steel sheet of the

type X₂CrNiMo₁₇₋₁₂₋₂ / 1.4404, cut and curved into hundreds of triangles, was used for the cladding. The triangles were electropolished in order to ensure a smooth surface and hence resistance to sticking of foreign particles. Obviously, this technique also enhances the ease of cleaning and an attractive, durable shiny mirror finish is obtained.

A number of specific requirements of particular applications have been indicated by the trade guild craftsmen Messrs. Prusvot, Robinet and Gaubert, and toge-

ther with the vigilant and accurate coordination of André Malicot, suggest that future versions of “Working with stainless steels” should become even more relevant to the real problems encountered with these materials on the shop floor. Grateful thanks are therefore due to the “Compagnons du Devoir” for their contribution.

Pierre-Jean CUNAT

1 Stainless steels

1.1 Forms of corrosion

The alteration of metals and alloys due to interaction with the surrounding medium is called *corrosion*. The attack begins at the surface of the metal, i.e. at its boundary with the environment, and then propagates inwards by different mechanisms.

Among the metallic materials that withstand corrosion, the stainless steels show excellent resistance in a large number of media, due to a phenomenon known as *passivity*. Stainless steels are protected from their environment by the formation of a very thin *passive film* or *passive layer* at the surface, strongly bonded to the substrate, which prevents further direct contact between the

metal and its more or less aggressive surroundings.

In order for the passivity phenomenon to occur in a stable manner, the stainless steel must contain a minimum amount of chromium of the order of 11%. Moreover, with this level of chromium, if the passive film is damaged locally, for example due to a scratch, it has the fundamental property of being able to heal itself in numerous different media. However, if the stainless steel grade has been poorly chosen for the medium concerned, *passivity breakdown* can occur, and the material corrodes.

There are a number of characteristic types of corrosion, and these are outlined below.

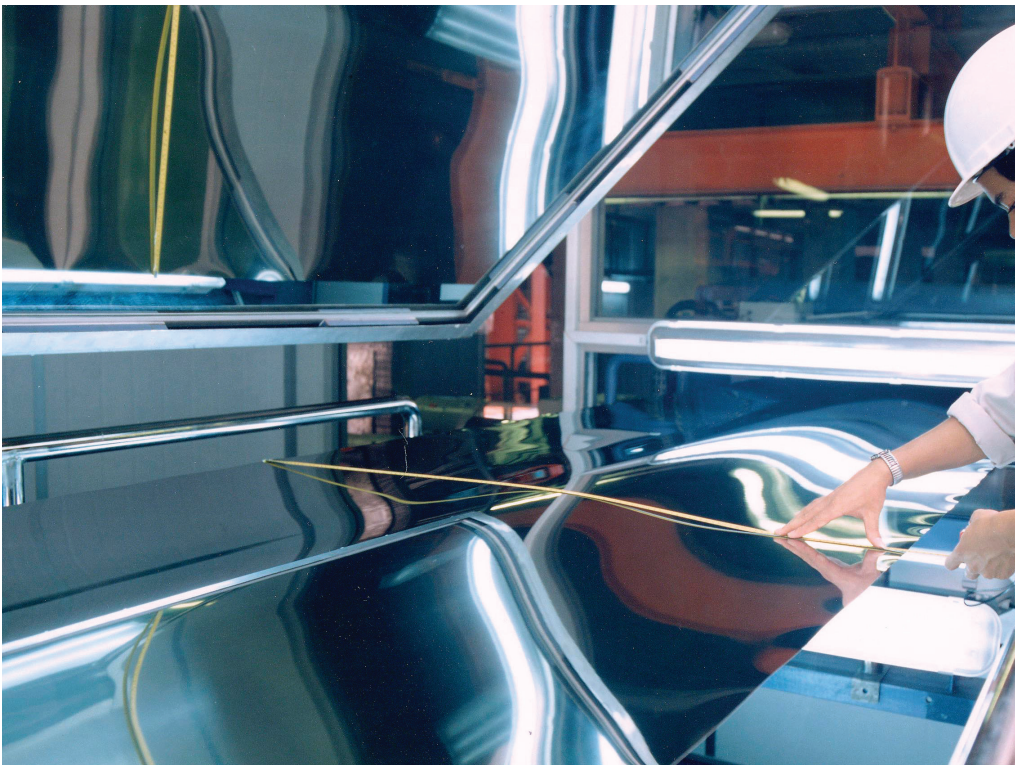

Photo 1: Bright annealing line – inspection stand



Photo 2: Atomium
Brussels. The renovated
spheres are now clad with
sandwich panels made of
1.2 mm outer skin of
X2CrNiMo17-12-2/t.4404
stainless steel grade –
Brussels (B)

Uniform corrosion

Strictly speaking, uniform corrosion is observed only when the stainless steel is in the active state, i.e. when a passive layer is unstable. In this case, dissolution occurs uniformly over the whole of the surface, leading to a regular decrease in metal thickness and a loss in weight.

Data concerning uniform corrosion are collected in corrosion tables giving the

behaviour of stainless steels in different *acid media*, generally free from impurities. Consequently, these data are not valid for all the possible media in which the steels are liable to be employed. They merely serve as guidelines for orienting the initial choice of material, which must be confirmed by consulting a corrosion specialist.

Localized corrosion

Stainless steels can undergo four types of localized corrosion, namely pitting, crevice

corrosion, intergranular corrosion and stress corrosion cracking.

Pitting corrosion

This type of attack occurs in a very limited region of the steel surface, the remainder of which is protected by a passive film. Local

rupture of the passive film is observed, and if self healing does not occur, a corrosion *pit* develops and can eventually lead to

complete perforation of the metal. It is therefore important to avoid the occurrence of this phenomenon by choosing the appropriate grade of stainless steel for the prevailing service conditions (fig. 1.1.1).

The type of medium most liable to promote pitting corrosion is undoubtedly sea water, but so-called “tap” or “fresh” waters can also be aggressive. The parameters that affect the resistance to pitting corrosion are :

- the surface condition of the material (low roughness is beneficial);
- the major alloying elements, namely chromium, molybdenum and nickel;
- the “minor” elements capable of modifying the non-metallic inclusions present in the metal.

From an electrochemical standpoint, it can be shown that a critical *pitting potential* exists on the anodic polarization curve for an alloy, beyond which localized corrosion can be initiated. For a given medium (e.g. tap water, sea-water), the pitting potential can be used to rank different steel grades in terms of their resistance to this type of attack. Thus, in tap water at 25 °C, with a typical NaCl content less than 1.2 g/l

(i.e. a molarity* of the order of 0.02 M) and a pH of 6.6, the results shown in Table 1.1.1 are obtained.

In sea water at 70 °C, which is much more corrosive, the NaCl content being of the order of 30 g/l (i.e. 0.5 M), the ranking obtained is given in Table 1.1.1.

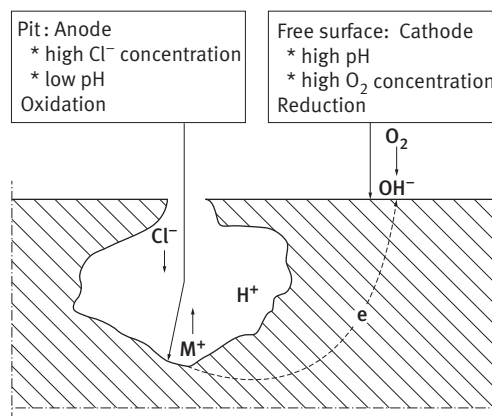

Fig. 1.1.1 - Schematic representation of the growth of a pit in a chloride-containing medium

- O₂ : oxygen molecule
- OH⁻ : hydroxyl ion
- Cl⁻ : chloride ion
- H⁺ : hydrogen ion
- M⁺ : metal ion
- e : electron

Grade: standard designation EN 10088-2	Resistance index (function of the pitting potential)	
	Tap water	Sea water
X6Cr17 / 1.4016	2.5	
X3CrTi17 / 1.4510	4.5	0.5
X2CrMoTi18-2 / 1.4521	7.0	2.0
X2CrNi19-11 / 1.4306	5.0	1.0
X2CrNiMo22-5-3 / 1.4462		4.0
X2CrMoTi29-4 / 1.4592		6.0 (Absence of pitting)

Table 1.1.1 - Pitting corrosion resistance of different stainless steels in tap water and sea water

(*) The mole (“mol” abbreviation) is the quantity of a substance which contains one gram formula weight of the substance. One mole of any substance contains 6.10²³ (Avogadro’s number) molecules or atoms. Formerly called one gram molecule. The molarity of a solution is the concentration expressed as the number of moles of the solute in 1 liter of solution.

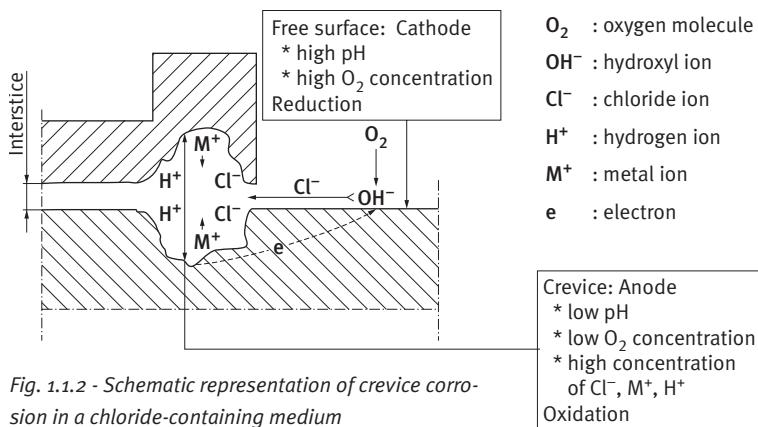

Fig. 1.1.2 - Schematic representation of crevice corrosion in a chloride-containing medium

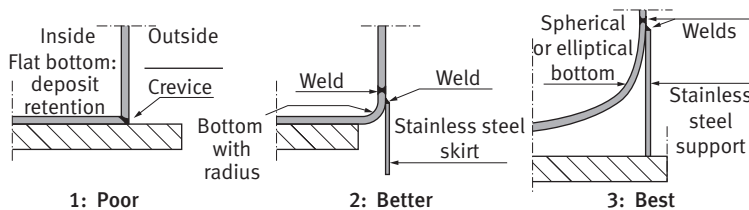

Fig. 1.1.3 - Welded vessel bottom designs

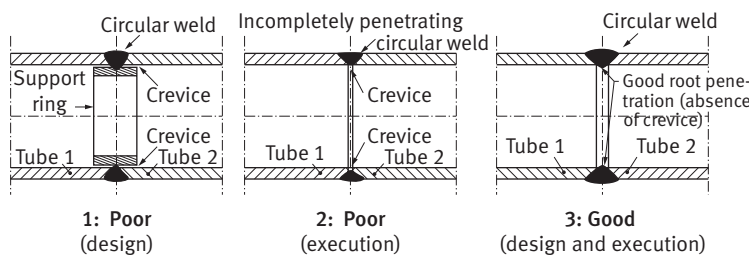

Fig. 1.1.4 - Butt-welded tubes

Crevice corrosion

As its name indicates, this type of attack occurs in *crevices* or confined spaces, due either to component or assembly design, or to the presence of deposits formed during service (fig. 1.1.2). The confined or semi-occluded region within a crevice promotes the accumulation of chemical species and the gradual acidification of the medium, facilitating breakdown of the passive film in the locally more aggressive environment. When the pH* in this zone reaches a critical value called the “depasivation pH”, corrosion begins. The incubation time before the onset of corrosion depends on the shape (severity) of the crevice. The depasivation pH is used to characterize the ability of an alloy to withstand crevice corrosion. The lower the depasivation pH, the greater the corrosion resistance. Values of the depasivation pH for the principal grades of stainless steel in a standard solution are given in Table 1.1.2.

- Crevice corrosion can be prevented by:
- a) appropriate design of equipment to avoid crevices (fig. 1.1.3 and 1.1.4);
 - b) systematically eliminating solid deposits (scale) formed during service;
 - c) avoiding the use of rubber joints, whose poor adhesion to the metal can create a crevice;

Depasivation pH	Acidity	Grade: Standard designation EN 10088-2
1	Very high	X2CrNiMo22-5-3 / 1.4462
1.1		X2CrMoTi29-4 / 1.4592
1.2		X1NiCrMoCu25-20-5 / 1.4539
1.8	High	X2CrNiMo17-12-2 / 1.4404
2.1		X5CrNi18-10 / 1.4301
2.5	Moderate	X3CrTi17 / 1.4510
3.0		X6Cr17 / 1.4016

Table 1.1.2 - Values of the depasivation pH for the principal grades of stainless steel in a standard solution

(*) The pH is a measure of the acidity or hydrogen ion content of an aqueous solution. A pH of the order of 7 corresponds to a neutral medium, while a much lower value, such as 3, represents an acidic medium, and values greater than 7 indicate alkaline or basic solutions. The definition of the pH is such that it varies on a logarithmic scale, i.e. a unit change in pH represents a ten-fold difference in concentration.

d) the suitable choice of material. In particular, austenitic stainless steels (Fe-Cr-Ni alloys) show better resistance than ferritic grades (Fe-Cr alloys). However, the major alloying element used to combat crevice corrosion is molybdenum, to the extent that an Fe - 18% Cr - 2% Mo ferritic stainless steel has better resistance than an Fe - 18% Cr - 8% Ni austenitic alloy.

Stress corrosion cracking

Stress corrosion cracking is a process whereby the combination of a mechanical load and a corrosive environment can lead to the initiation of cracks, sometimes after a long incubation period, which can subsequently propagate rapidly and cause failure of the equipment concerned (fig. 1.1.5). The phenomenon is often difficult to detect before cracking has reached a stage where it threatens the life of the installation. The measures to be taken to avoid the occurrence of stress corrosion cracking are:

- the use, whenever possible, of ferritic grades, which are generally insensitive to this type of corrosion;
- if the medium is aggressive, the use of either a duplex austenitic-ferritic grade or an austenitic alloy with high nickel and molybdenum contents;
- attenuation of residual stresses by performing a stress relieving treatment on the equipment before putting it into service, and limitation of operating loads (particularly due to vibrations, thermal expansion, etc.).

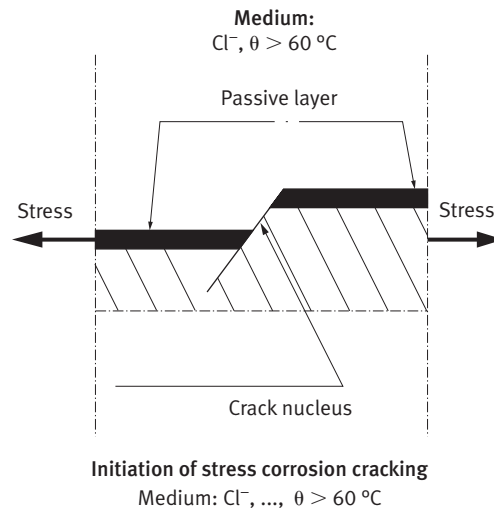
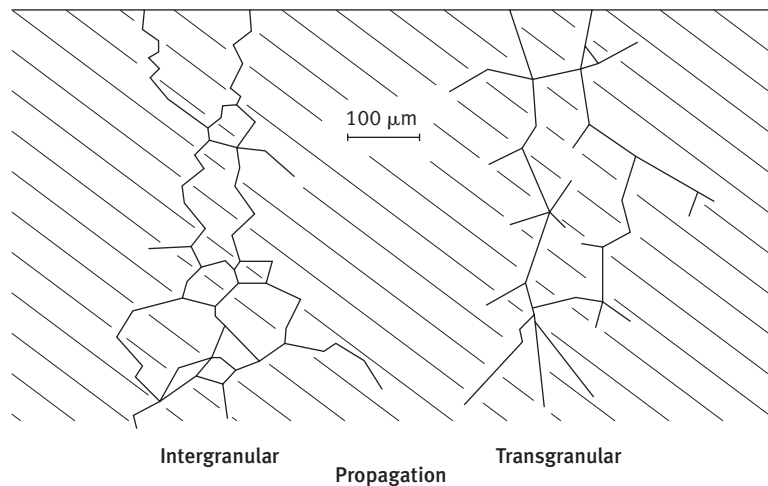

Fig. 1.1.5 - Schematic representation of stress corrosion cracking



Intergranular corrosion

When certain materials are heated between 500 and 800 °C, the grain boundaries can become “sensitized” and undergo preferential attack when subsequently exposed to a corrosive medium. This often occurs during welding operations, in the region of the heat affected zone (HAZ) (fig. 1.1.6) which has been exposed to temperatures in this range. A number of remedies are available for preventing intergranular corrosion:

- a) For austenitic alloys (Fe-Cr-Ni or Fe-Cr-Ni-Mo), the choice of a grade with either a low carbon content ($C < 0.03\%$) or the addition of a “stabilizing” element such as titanium.
- b) For ferritic alloys (Fe-Cr or Fe-Cr-Mo), it is imperative to choose a grade stabilized with either titanium or niobium.
- c) If a stainless steel has become sensitized, its structure can be regenerated by an annealing treatment followed by rapid cooling, the appropriate temperature being 700 to 800 °C for ferritic materials and 1050 °C for austenitic grades.

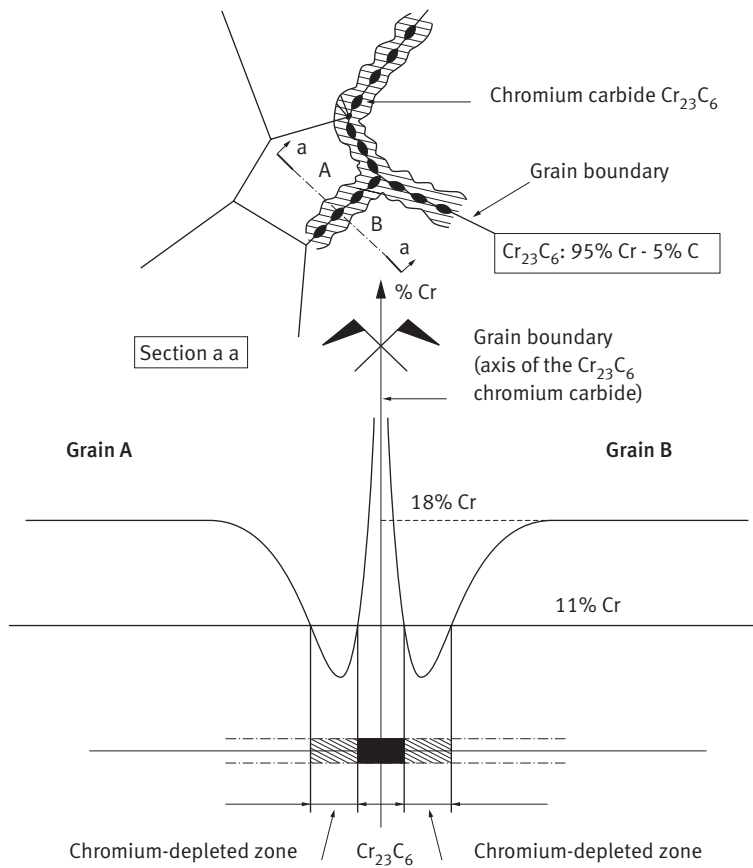

Fig. 1.1.6 - Schematic representation of sensitization to intergranular corrosion due to chromium depletion at grain boundaries in a type X5CrNi18-10 / 1.4301 stainless steel

High temperature corrosion

There is no really strict definition of what constitutes the “high temperature” region, but for the typical applications of stainless steels, the lower threshold is commonly considered to be about 500 °C. In this range, the corrosion mechanisms are different depending on the oxidizing potential of the atmosphere. Highly “oxidizing” gaseous atmospheres include air, oxygen, water vapor, sulfur and its oxides (SO₂ and SO₃), carbon dioxide (CO₂), nitrogen oxides

(NO_x) and chlorine. “Reducing” gases are those containing hydrogen, hydrogen sulfide (H₂S), carbon monoxide (CO), hydrocarbons, ammonia, etc. Molten salts can be either oxidizing or reducing towards stainless steels. Finally, certain molten metals can cause corrosion by direct dealloying effects.

“Oxidizing” atmospheres

When stainless steels are heated in an oxidizing atmosphere, the presence of chromium leads to the formation of a protective scale, based on the chromium oxide Cr₂O₃, sometimes overlain by a layer of spinel, such as FeCr₂O₄.

The difference in thermal expansion between the oxide and the metal substrate has an important effect on the stability of the scale, particularly when the service conditions involve frequent thermal cycling. It is essentially for this reason that ferritic

(Fe-Cr) grades often perform better than austenitic (Fe-Cr-Ni) alloys under severe thermal cycling conditions, since the expansion coefficient of austenite is about 1.6 times that of ferrite, while the value for the scale is very small. Table 1.1.3 gives the recommended maximum service temperatures for applications involving oxidizing atmospheres.

Grade EN 10088-2 Standard designation	Limiting service temperature (°C)	
	Continuous	Cyclic
Austenitic grades		
X5CrNi18-10 / 1.4301	930	870
X8CrNi25-21 / 1.4845	1150	1030
Ferritic grades		
X6Cr17 / 1.4016	820	870
X2CrMoTi29-4 / 1.4592	1090	1170

Table 1.1.3 -
Recommended maximum
service temperatures in
oxidizing atmospheres
for ferritic and austenitic
stainless steels

The addition of at least 2%, and possibly up to 5 or 6% of aluminum, together with small quantities of cerium, lanthanum and/or yttrium, produces a tenacious and highly protective alumina scale. For example, ferritic alloys containing about 20% Cr together with aluminum and rare earth additions of this sort are used for metal catalyst supports for automobile exhaust gas purification systems. In this application, when

the engine is at full speed, the temperature can reach nearly 1000 °C, while the gas contains nitrogen oxides (NO_x), hydrocarbons (HC), volatile organic compounds (VOC) and carbon monoxide (CO), which are converted by catalytic reaction to “non-polluting” species, such as CO_2 , H_2O , N_2 and O_2 .

“Reducing” atmospheres

Among the commonest types of “reducing” atmosphere are those rich in carbon monoxide or hydrocarbons, which can promote carburizing. In addition to chromium, nickel and silicon are effective alloying elements for improving the resistance to this type of attack, and their combined action has been quantified in terms of an index given by the formula $\% \text{Ni} + 9 \times \% \text{Si}$. A common low temperature form of carburizing is the phenomenon known as “metal dusting”, in which the metal disintegrates at the surface due to excessive absorption of carbon deposited from the gas.

Nitriding can occur at high temperatures due to reaction with the atomic nitrogen produced by the cracking of ammonia in contact with the metal surface. Since nitrogen has a strong affinity for titanium, aluminum and chromium, it will preferentially form nitrides within the metal. In order to ensure a sufficiently protective oxide scale to limit nitriding, nickel contents greater than 35% are generally necessary. However, a 21% Cr – 11% Ni grade containing cerium

has been found to show good resistance in cracked ammonia up to 1100 °C.

In atmospheres containing hydrogen sulfide at temperatures above 800 °C, nickel is detrimental, since it forms a low melting point eutectic $\text{Ni}/\text{Ni}_3\text{S}_2$, and the best results are obtained with ferritic grades.

Finally, in hydrogen-containing atmospheres, the pressure plays an important role in the risk of hydrogen uptake. At pressures of the order of 300 bars and temperatures above 600 °C, 12% Cr martensitic grades are usually used.

1.2 The stainless steel family

The major families of stainless steels

The table below summarizes the principal families of commercially available stainless steels, i.e. those produced in large quantities and which cover more than 90% by volume of all market requirements. The high productivity manufacturing route typically involves

electric arc furnace melting, refining in an argon – oxygen – decarburizing (A.O.D.) converter, hot rolling on a strip or Steckel mill, initial annealing, continuous pickling, cold rolling on a Sendzimir type mill, continuous final annealing, then finishing.

<ul style="list-style-type: none"> • Martensitic grades 	<p>Stainless steels capable of undergoing an austenite to martensite transformation on quenching. Depending on the composition and heat treatment, the hardnesses obtained can range from 40 to 60 HRC</p>
<ul style="list-style-type: none"> – carbon \geq 0.1% – 12 to 18% chromium 	
<ul style="list-style-type: none"> • Ferritic grades 	<p>The Yield Strength (YS) of these grades is typically in the range 250 to 380 N/mm² and their Ultimate Tensile Strength (UTS) from 410 to 700 N/mm², with elongations from 20 to 32%. They cannot generally be hardened by heat treatment.</p>
<ul style="list-style-type: none"> – 0.02 to 0.06% carbon – 0 to 4% molybdenum – 11 to 29% chromium 	
<ul style="list-style-type: none"> • Austenitic grades 	<p>The YS of these grades is typically in the range 215 to 360 N/mm² and their UTS from 600 to 800 N/mm², with elongations from 40 to 55%. Their high ductility gives them a remarkable capacity for forming.</p>
<ul style="list-style-type: none"> – 0.015 to 0.10% carbon – 0 to 4% molybdenum – 7 to 25% nickel – 17 to 20% chromium 	
<ul style="list-style-type: none"> • Heat resisting austenitic grades 	<p>The mechanical properties of these alloys are similar to those of the ordinary austenitic grades. However, due to their higher carbon contents, they conserve good strength at high temperature.</p>
<ul style="list-style-type: none"> – carbon \leq 0.2% – 11 to 22% nickel – 19 to 26% chromium 	
<ul style="list-style-type: none"> • Duplex austenitic-ferritic grades 	<p>These grades have a very high YS ($>$ 620 N/mm²), and a UTS $>$ 800 N/mm², together with an elongation greater than 40%.</p>
<ul style="list-style-type: none"> – 0.02% carbon – 3% molybdenum – 22% chromium – 5.5% nickel <p>} Typical composition</p>	

Table 1.2.1 - Major families of stainless steels

The mechanical properties of the principal stainless steel grades available on the market are given in Table 1.2.2, together with their standard designations.

Table 1.2.2 - Mechanical properties of different stainless steels in the annealed condition

European designation (EN 10088-2) Name	Number	AISI (1) or commercial American designation	Mean mechanical properties		
			UTS (2)	0,2% YS (3)	El. (%) (4)
Martensitic stainless steels					
X20Cr13	1.4021		550	340	24
X30Cr13	1.4028	420	600	340	24
X46Cr13	1.4034		650	400	23
Ferritic stainless steels					
X6Cr13	1.4000	410S	480	330	26
X2CrTi12	1.4512	409	410	250	32
X2CrNi12	1.4003		510	370	27
X8Cr17	1.4016	430	500	340	26
X3CrTi17	1.4510	430Ti	450	300	30
X2CrMoTi18-2	1.4521	444	540	380	27
Austenitic stainless steels					
X10CrNi18-8	1.4310	301	740	320	50
X5CrNi18-10	1.4301	304	630	300	52
X2CrNi18-9	1.4307	304L	620	310	50
X2CrNi19-11	1.4306	304L	600	300	50
X6CrNiTi18-10	1.4541	321	610	280	48
X4CrNi18-12	1.4303	305	580	250	52
Molybdenum-containing austenitic stainless steels					
X5CrNiMo17-12-2	1.4401	316	620	340	48
X2CrNiMo17-12-2	1.4404	316L	610	310	45
X6CrNiMo17-12-2	1.4571	316Ti	610	310	47
X1NiCrMoCu25-20-5	1.4539	904L	650	340	40
Duplex austenitic-ferritic stainless steel					
X2CrNiMo22-5-3	1.4462		840	620	30
Heat resisting austenitic stainless steels (EN 10095)					
X15CrNiSi20-12	1.4828		620	310	50
X12CrNi23-13	1.4833	309S	630	330	45
X8CrNi25-21	1.4845	310S	600	300	42

- (1) AISI: American Iron and Steel Institute.
(2) UTS: Ultimate Tensile Strength (N/mm²).
(3) 0.2% YS: Yield Strength 0.2% offset (N/mm²).
(4) El. (%): Elongation in 80 mm (%).

Principal applications

The most significant applications for the different grades are given below.

Austenitic stainless steels (0.015 – 0.1% C, 17 – 20% Cr, 7 – 25% Ni, 0 – 4% Mo)

The principal applications concern the storage and treatment of foodstuffs, collective catering and hospital equipment. They also constitute the standard materials for chemical engineering equipment and are widely employed for domestic utensils and appliances.

Ferritic stainless steels (0.02 – 0.06% C, 11 – 29% Cr)

The 11% Cr steels are used in automotive exhaust systems, where the atmospheres are moderately aggressive. The principal application of the 17% Cr grades is for the manufacture of domestic implements and appliances. The 29% Cr alloys have exceptional corrosion resistance and are essentially used in contact with sea water.

Duplex austenitic-ferritic stainless steels

The most commonly used duplex grade is the 0.02% C – 22% Cr – 5.5% Ni – 3% Mo alloy, whose standard European designation is X2CrNiMo22-5-3 / 1.4462. Its principal applications concern equipment for papermaking and chemical and offshore engineering.

Martensitic stainless steels (C > 0.1%, 12 – 14% Cr)

Like many plain carbon steels, these alloys are used in the quenched and tempered condition, giving the end product a hardness perfectly adapted to the intended utilization. Depending on the grade considered, the principal applications are for cutlery and surgical instruments.

1.3 Choice of a stainless steel grade

Various criteria of stainless steel selection

The choice of a stainless steel grade is usually based on a number of criteria, including the fulfillment of functional requirements, fabricability, and cost effectiveness for the intended application. The following fundamental factors are favorable for stainless steels in general:

- *Corrosion resistance and general durability:*
Stainless steels have excellent corrosion resistance in a wide variety of media.
- *High mechanical strength at high temperatures and remarkable strength and ductility at low temperatures:*
Stainless steels have excellent strength, ductility and toughness over a very wide temperature range, from cryogenic temperatures to more than 1000 °C.
- *Attractive appearance:*
Stainless steel is a modern material whose long lasting appearance is one of its essential features.
- *Ease of implementation:*
Stainless steels can be readily formed (drawing, contour forming, etc.) and joined (welding, adhesive bonding, etc.).
- *Stainless steels do not alter the taste of foodstuffs:*
This is an important property for the agriculture, food and beverage processing industries.
- *Stainless steels are easy to clean, disinfect and sterilize:*
and have perfect resistance to the reagents used for these purposes (e.g. high pressure steam for sterilization).
- *Low overall costs (ownership or life cycle cost):*
When the equipment purchase price plus its lifetime maintenance costs are considered, stainless steel is a cost-effective material.
- *Recyclability:*
Stainless steel can be 100% recycled, and is effectively recycled to produce the same quality level as in the initial material.

The combination of the above criteria has led to the widespread use of stainless steel in the agriculture, food and beverage processing industries, including the following applications:

- fruit juices,
- beer (processing and distribution),
- chocolate,
- tomatoes (harvesting and processing),
- fish (handling and processing),
- cheese (from milking to final conditioning),
- wine (grape harvesting, vinification, storage).

They are also extensively used in transport equipment (railroad cars, wagons, truck tanks, refrigerated containers, bus bodies, etc.), in chemical and petrochemical engineering, in the oil industry, in electronics

(non-magnetic components for electron guns, glass-metal fixing pins) and in the building industry (curtain walling, elevator cages, escalators, roofs, fume ducts, street furnishings, etc.). This list is by no means exhaustive and stainless steels are used for a large number of everyday objects, of which coinage is a good example.

On the basis of the above fundamental criteria, the following list of applications and appropriate steel grades has been drawn up, classified according to the five major families of stainless steels already described (Chapter 2 and annex I).

In which specific cases should a stainless steel be chosen (in accordance with the five families)

Austenitic stainless steels (0.015 - 0.1% C, 17 - 20% Cr, 7 - 25% Ni, 0 - 4% Mo)

- *Milk storage tanks*
 - X5CrNi18-10 / 1.4301
- *White wine storage tanks*
 - X2CrNiMo17-12-2 / 1.4404
- *Beer kegs*
 - X5CrNi18-10 / 1.4301
- *Equipment for collective catering, hospitals, foodstuff handling, etc.*
 - X5CrNi18-10 / 1.4301
 - X2CrNiMo17-12-2 / 1.4404
 - X2CrNi18-9 / 1.4307
- *Sink bowls and complete sink unit*
 - X5CrNi18-10 / 1.4301
- *Dishwasher tubs and door linings*
 - X5CrNi18-10 / 1.4301
- *Cooking utensils*
 - X5CrNi18-10 / 1.4301
- *Cutlery and dishes*
 - X5CrNi18-10 / 1.4301
- *Bus and coach bodies*
 - X5CrNi18-10 / 1.4301
- *Fume ducts*
 - X5CrNi18-10 / 1.4301
 - X2CrNiMo17-12-2 / 1.4404
 - X1NiCrMoCu25-20-5 / 1.4539

depending on the technology (rigid, flexible, single or double wall, with or without condensation, type of fuel, etc.).
- *Hot water tanks*
 - X2CrNiMo17-12-2 / 1.4404
 - X6CrNiMoTi17-12-2 / 1.4571

Ferritic stainless steels (0.02 - 0.06% C, 11 - 29% Cr)

- *Domestic appliances: washing machine and drier drums, dishwasher tubs*
 - X6Cr17 / 1.4016
- *Sink bowls and drainboards*
 - X6Cr17 / 1.4016
 - X3CrTi17 / 1.4510
- *Cutlery, dishes, pan lids*
 - X6Cr17 / 1.4016
- *Automobile hose clamps*
 - X6Cr17 / 1.4016
- *Decorative automobile trimmings*
 - X6Cr17 / 1.4016
 - X6CrMo17-1 / 1.4113
 - X6CrMoNb17-1 / 1.4526
- *Washing machine tubs*
 - X3CrTi17 / 1.4510
- *Hot water tanks*
 - X2CrTi17 / 1.4520
 - X2CrMoTi18-2 / 1.4521
- *Automotive exhaust systems*
 - X2CrTi12 / 1.4512
 - X2CrTiNb18 / 1.4509
- *Drier-superheater tubes (electric power stations)*
 - X3CrTi17 / 1.4510
- *Evaporator and reheater tubing and boilers for sugar refineries*
 - X3CrTi17 / 1.4510
- *Fume ducts*
 - X2CrMoTi18-2 / 1.4521
 - X2CrMoTi29-4 / 1.4592
- *Tubing for seawater desalination plants*
 - X2CrMoTi29-4 / 1.4592
- *Conveyor belt chains*
 - X6CrNi17-1 / 1.4017
- *Structural elements, container frames, wagons, hoppers, bus and coach bodies*
 - X2CrNi12 / 1.4003
- *Coinage*
 - X6Cr17 / 1.4016 with low carbon content

Duplex austenitic – ferritic stainless steels

The most commonly used duplex grade is the 0.02% C – 22% Cr – 5,5% Ni – 3% Mo alloy, whose standard European designation is X2CrNiMo22-5-3. Its principal applications are as follows:

- *Chemical engineering*
 - heat exchangers for PVC plants
 - equipment for handling organic acids
 - tanks and tubing
- *Papermaking*
 - pressure vessels
 - pre-impregnators
- boilers
- kraft pulp digesters
- *Offshore engineering*
 - seamed spiral tubing
 - fire resistant walls
- *Miscellaneous*
 - plates for electrostatic precipitators

Martensitic stainless steels**(C > 0.1%, 12 – 14% Cr)**

Like many plain carbon steels, these alloys are used in the quenched and tempered condition, giving the end product a hardness perfectly adapted to the intended utilization. Depending on the grade considered, the principal applications are as follows:

- *Knife blades*
 - X20Cr13 / 1.4021
 - X30Cr13 / 1.4028
 - X46Cr13 / 1.4034
- *Shear blades for the paper industry*
 - X30Cr13 / 1.4028
- *Compressor membranes, springs*
 - X20Cr13 / 1.4021
- *Surgical instruments*
 - X30Cr13 / 1.4028
 - X46Cr13 / 1.4034

Heat resisting austenitic stainless steels

- *Furnace components, heat exchangers*
 - X12CrNi23-13 / 1.4833
 - X8CrNi25-21 / 1.4845
- *Burners*
 - X12CrNi23-13 / 1.4833
- *Furnace bells*
 - X15CrNiSi20-12 / 1.4828
- *Automobile exhaust manifolds*
 - X15CrNiSi20-12 / 1.4828

1.4 Heat treatment

Martensitic stainless steels

The martensitic stainless steels generally have chromium contents ranging from 11.5 to 18% and carbon levels between 0.15 and 1.2%. A noteworthy application is for cutlery manufacture. The microstructure of these materials on delivery usually consists of a uniform dispersion of carbides in ferrite, although some thin strip is supplied in the as-quenched condition. Before use, for example in cutlery, quenching and tempering is therefore normally necessary to obtain a fully martensitic structure with no chromium carbides.

In order to develop a completely martensitic structure, it is necessary to heat the metal into the single phase austenite field, above the A_{c3} transformation point, generally of the order of 900 °C, depending on the chromium and carbon contents. For alloys with between 11.5 and 13.5% Cr and carbon contents less than 0.15%, the A_{c3} point is situated at about 920 °C and austenitizing is performed between 950 and 1100 °C. For carbon contents between 0.15 and 0.5% and chromium levels from 12 to 16%, A_{c3} lies between 850 and 900 °C and austenitizing is also carried out in the range from 950 to 1100 °C. For grades containing 0.6 to 1.2% C and 17 to 18% Cr, A_{c3} is between 830 and 860 °C and quenching is performed from temperatures between 1000 and 1050 °C. Finally, there is a fourth category of stainless steels, with less than 0.2% C and from 12 to 18% Cr, and also containing from 1.5 to 5% Ni, whose A_{c3} is between 800 and 900 °C and which are austenitized between 950 and 1000 °C.

The holding time at the austenitizing temperature depends on the thickness, and must be long enough to allow complete solutioning of

all chromium carbides. Subsequent cooling down to ambient temperature must be effective in less than one minute. For thin sections, natural or forced air cooling is often sufficient, whereas oil quenching is necessary for thicknesses greater than about 5 mm. If chromium carbides are observed after cooling, either the austenitizing temperature was too low or the holding time too short. The hardness will then be too low, since the carbon content of the martensite is reduced, and the corrosion resistance may also be impaired.

In high carbon grades, the austenite does not transform fully to martensite on cooling to room temperature, and the presence of residual austenite lowers the overall hardness. The transformation can be effectively completed with the aid of a cryogenic treatment at about -80 °C. The thermal shock induced during rapid cooling generates internal stresses which can cause embrittlement. In order to improve the ductility and toughness, a stress relieving treatment is therefore performed, involving heating for a few hours at 150 to 300 °C. It is absolutely essential to avoid the temperature range 400-600 °C, in which chromium carbide precipitation can occur, accompanied by chromium depleted zones which can make the alloy sensitive to intergranular corrosion.

Ferritic stainless steels

In metallurgical terms, the ferritic stainless steels are not all identical, since, while some remain ferritic at all temperatures, the so-called semi-ferritic grades can form up to 30% of austenite at high temperatures, which transforms to martensite on cooling. Furthermore, in non-stabilized alloys, which includes the semi-ferritic grades, holding in the temperature range 900-950 °C followed by slow cooling can lead to the precipitation of chromium carbides and sensitization to intergranular corrosion due to chromium depletion at grain boundaries. The ductility and corrosion resistance of the semi-ferritic alloys can be restored by heat treatment between 750 and 850 °C, for a time which depends on product thickness, a value of one to two minutes per millimeter being recommended. Subsequent cooling, particularly through the temperature range around 475 °C, must be sufficiently rapid to avoid embrittlement. Indeed, at temperatures between 400 and 500 °C, the ferrite matrix splits into two separate body cubic centered (bcc) phases, with respectively high and low chromium contents, the rate of reaction being a maximum at 475 °C. The 11% Cr ferritic grades are virtually insensitive to this phenomenon, which occurs only to a slight extent in 17% Cr alloys, whereas the 25% Cr materials are highly prone to it.

The grades with more than 25% Cr are also susceptible to the formation of the brittle chromium-rich sigma phase between 500 and 800 °C. It can be taken back into solution by heat treatment at 1000 °C for about half an hour, followed by rapid cooling.

The semi-ferritic 17% Cr alloys have a two-phase austenite + ferrite field situated

between 850 and 1100 °C. If the alloy has been held in this region, martensite will be present on cooling to room temperature. In fact, the embrittlement of these materials due to martensite is only relative, and is much less detrimental than the presence of chromium carbides at grain boundaries, which not only impair the corrosion resistance, but also promote intergranular fracture at high stresses. Embrittlement of semi-ferritic grades (e.g. X6Cr17/1.4016) due to the precipitation of chromium carbides, nitrides or carbonitrides appears after holding at temperatures above 900-950 °C. This phenomenon can be avoided by ensuring a correctly balanced alloy chemistry. Thus, the interstitial elements, carbon and nitrogen, must be limited to a total content of not more than 0.020%, and must be tied up with titanium, which forms TiN nitrides in the liquid phase during solidification, and/or with niobium, both elements forming carbonitrides in the solid phase.

Another group of alloys which can be included with the ferritic grades includes the dual-phase ferrite-martensite materials, whose high temperature structures contain up to 50% of austenite, and which consist of ferrite and about 10% martensite at ambient temperature. The heat treatment employed for these alloys is designed to form the amount of austenite necessary to produce the required quantity of martensite in the final structure. The cooling rate must be greater than 20 °C/hour to prevent the presence of residual austenite.

Austenitic stainless steels

Solution annealing

The aim of solution annealing is to obtain a fully homogeneous austenitic structure at ambient temperature. Annealing is performed at 1000 to 1150 °C, depending on

the grade, with a holding time of the order of one to three minutes per millimeter of thickness, and is followed by very rapid air or water cooling.

“Anti-ferrite” treatment

A certain amount of high temperature delta ferrite can be retained in austenitic stainless steels. This phase is not generally detrimental, but may become embrittled due to the formation of sigma phase between

550 and 900 °C. This residual ferrite can be eliminated by holding for about 36 hours at 1150 °C, followed by slow furnace cooling to 1050 °C, then rapid cooling down to ambient temperature.

Stress relieving treatments

The various processing operations during the manufacture of a component can generate internal stresses which can have a detrimental influence on the service life of the equipment in which it is employed, for example, due to stress corrosion cracking. In order to eliminate or attenuate these residual stresses, two types of stress relieving treatments can be employed:

- a) Long holding (10 to 20 minutes per millimeter of thickness) at a temperature between 200 and 400 °C, followed by slow cooling. This treatment has the advantage that it does not cause any phase transformations.
- b) For grades not prone to intergranular corrosion, short holding (about 3 minutes per millimeter of thickness) at about 850 °C.

Duplex austenitic-ferritic stainless steels

Solution annealing

For duplex austenitic-ferritic stainless steels, the aim of solution annealing treatments is generally to obtain a mixture of roughly 50% austenite and 50% ferrite at room temperature, without the presence of intermetallic phases or other precipitate particles. It is essential to avoid the precipitation of intermetallic phases during cooling, particularly since the ferrite in duplex grades is also sensitive to the 475 °C embrittlement phenomenon. Residence times in the range 950 to 700 °C must be as short as possible in order

to limit the risk of sigma phase formation. In molybdenum-containing grades, the dangerous zone extends up to 1050 °C. The recommended annealing temperature is therefore about 1050 °C for molybdenum-free alloys and 1100 °C when this element is present. Bearing this in mind, the temperature must be chosen in the range 1000-1150 °C, according to the required volume fractions of austenite and ferrite.

Post-weld heat treatment

Since duplex austenitic-ferritic stainless steels are not sensitive to intergranular corrosion, from this point of view they do not really require post-weld heat treatment. However, the welding operation, particularly in the case of a single pass process without filler metal, destroys the balance between austenite and ferrite in the weldment,

where it is common to find ferrite contents of 90% and more. In order to restore a more balanced phase mixture, it is recommended to perform a solution annealing treatment as described under the section “solution annealing”.

1.5 Commercially Available Stainless Steel Products

A major distinction is generally made between flat (about 85% world stainless steel consumption) and long products (about 15% world stainless steel consumption) (Table 1.5.1 and 1.5.2).



Photo 3: Slitting line in action

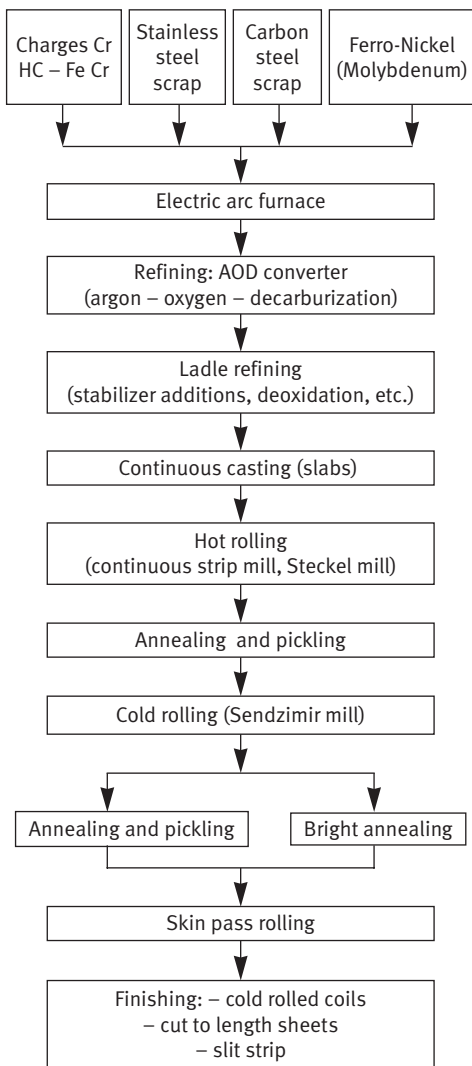

Table 1.5.1 - Principal manufacturing route for coiled stainless steel strip products

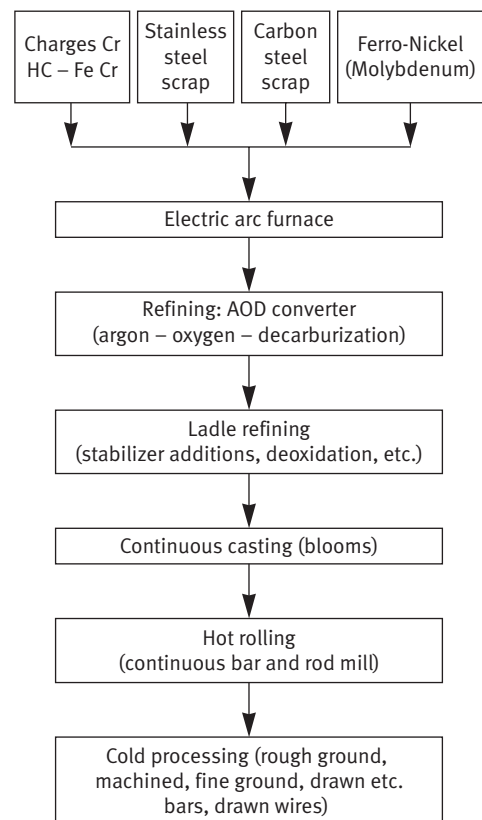

Table 1.5.2 - Principal manufacturing route for stainless steel long products

Flat products

Flat products represent about 85% of world stainless steel consumption. They can be subdivided into:

- Coiled strip, including:
 - hot rolled strip, in thicknesses from 2.0 to 13.0 mm,
 - cold rolled strip, in thicknesses from 0.3 to 8.0 mm, together with extra-thin strip with thicknesses down to 50 µm, which can be supplied in widths up to 1000 mm.

The most common strip width is 1250 mm, although widths up to 1500 mm, and exceptionally 2000 mm are available for some thicknesses.

- Sheets and plates, with thicknesses up to 150 mm and widths up to about 4000 mm.

The largest volume corresponds to cold rolled strip, which alone represents more than 75% of total flat product usage.

These products are employed either in the annealed (ferritics) or solution treated and quenched (austenitics, duplex grades) condition, or in the cold-worked state, in order to obtain higher yield and tensile strengths. Indeed, the ferritic grades X6Cr17 / 1.4016 and X6CrMo17-1 / 1.4113

are frequently used in the cold worked condition, and this is even more common for the austenitic alloys X10CrNi18-8 / 1.4310, X5CrNi18-10 / 1.4301 and X2CrNi18-7 / 1.4318, whose mechanical strength can be considerably increased by controlled cold work.

Table 1.5.3 gives the mechanical properties obtained in the cold worked condition for the most representative ferritic and austenitic grades.

These different strength levels are obtained by appropriate amounts of cold rolling. The class C850 corresponds roughly to quarter hard temper, the class C1000 to half hard, class C1150 to threequarters hard and class C1300 to full hard, i.e. the maximum allowable cold reduction.

These flat products can be delivered with a wide variety of surface conditions, the principal ones being:

- N°. 1 finish, corresponding to the surface condition of a hot rolled strip after annealing and pickling (1D condition).
- N°. 2 finish, corresponding to the surface condition of a cold rolled strip after annealing and pickling (2D condition).

Standard designation EN 10088-2	UTS (N/mm ²) for different degrees of cold work				
	C700	C850	C1000	C1150	C1300
X6Cr17 / 1.4016	700/850	850/1000			
X6CrMo17-1 / 1.41133	700/850	850/1000			
X10CrNi18-8 / 1.4310		850/1000	1000/1150	1150/1300	1300/1500
X5CrNi18-10 / 1.4301		850/1000	1000/1150	1150/1300	1300/1500
X2CrNi18-7 / 1.4318		850/1000	1000/1150		

Table 1.5.3 - Ultimate Tensile Strength (UTS) of stainless steels in different "temper" (cold worked) categories

- N°. 2B finish corresponds to condition 2D after “skin-pass” rolling, to decrease the roughness and thus enhance the brightness (2B condition).
- The bright annealed finish is obtained by performing the final annealing treatment in a controlled atmosphere (a nitrogen-hydrogen mixture or pure hydrogen).

This gives a very smooth surface whose brightness is enhanced by skin-pass rolling (2R condition).

In addition to the above surface conditions, a wide variety of other finishes exist, such as polished (2G conditions), brushed satin (2J conditions) and etched (leather, canvas, etc. - 2M conditions) (fig. 1.5.1).

HOT PROCESSING

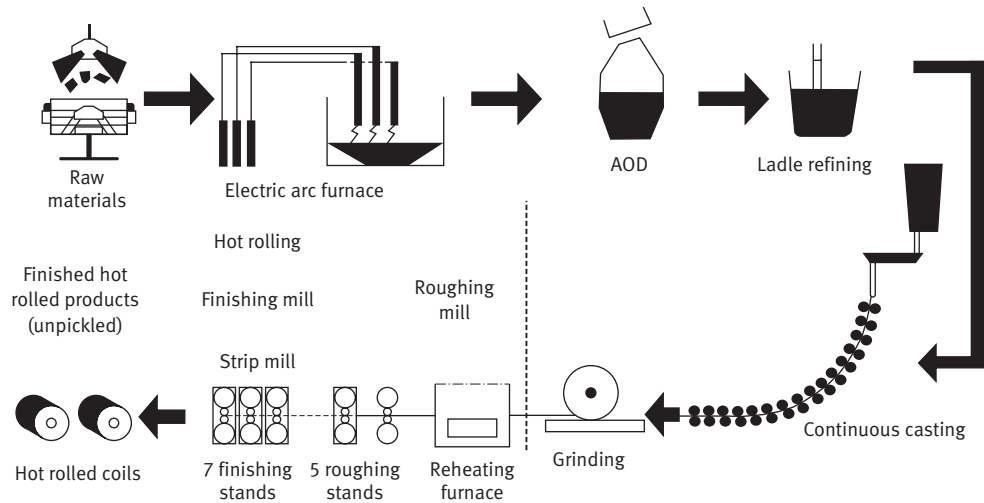

COLD PROCESSING

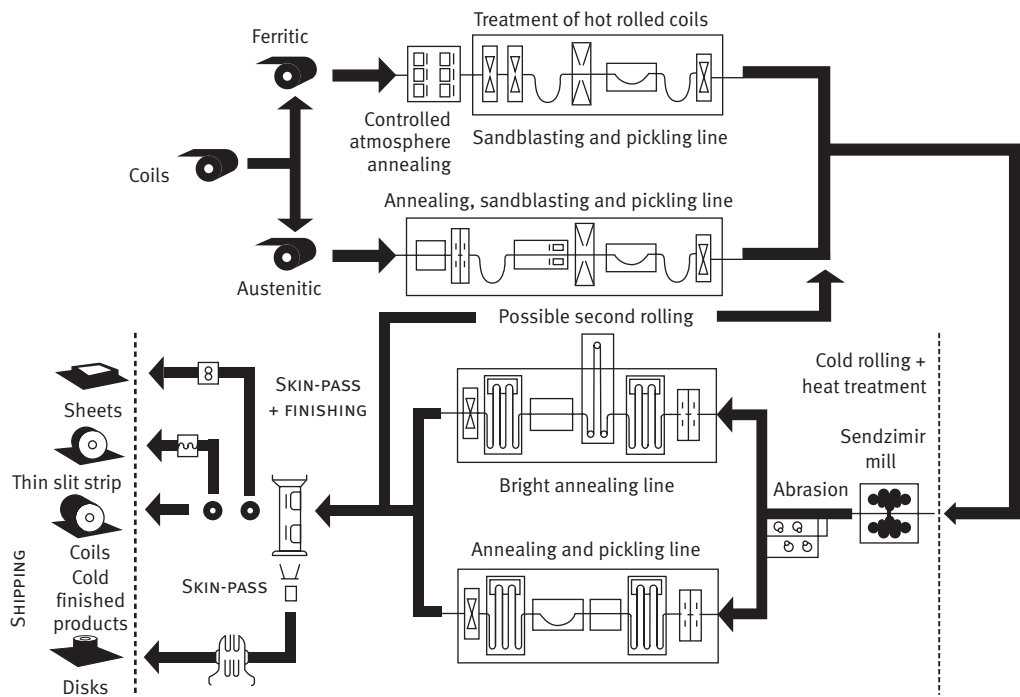

Fig. 1.5.1 - Manufacturing route for stainless steel flat products

Long products

Long products represent about 15% of world stainless steel consumption. They consist typically of bars, wires, standard sections (round, square, rectangular) and special sections (angle irons, U, T and I beams). These products can be delivered in the hot rolled condition, possibly after different thermal and mechanical treatments, such as descaling, peeling, etc., or after cold processing (drawn, machined, ground, polished, etc.)

In the case of bar and rod, the most common diameters range from 2 to 45 mm. Products with diameters less than or equal

to 10 mm can be given a so-called decorative polish. Wire and wire rod with diameters from 2 to 16 mm are frequently used for cold heading (fasteners). The building industry uses wires with diameters between 2 and 5 mm for decorative purposes, while slate hooks are made from 2.4 to 2.7 mm diameter wire.

The manufacturing route for stainless steel long products is illustrated in figure 1.5.2.

Fig. 1.5.2 - Manufacturing route for stainless steel long products

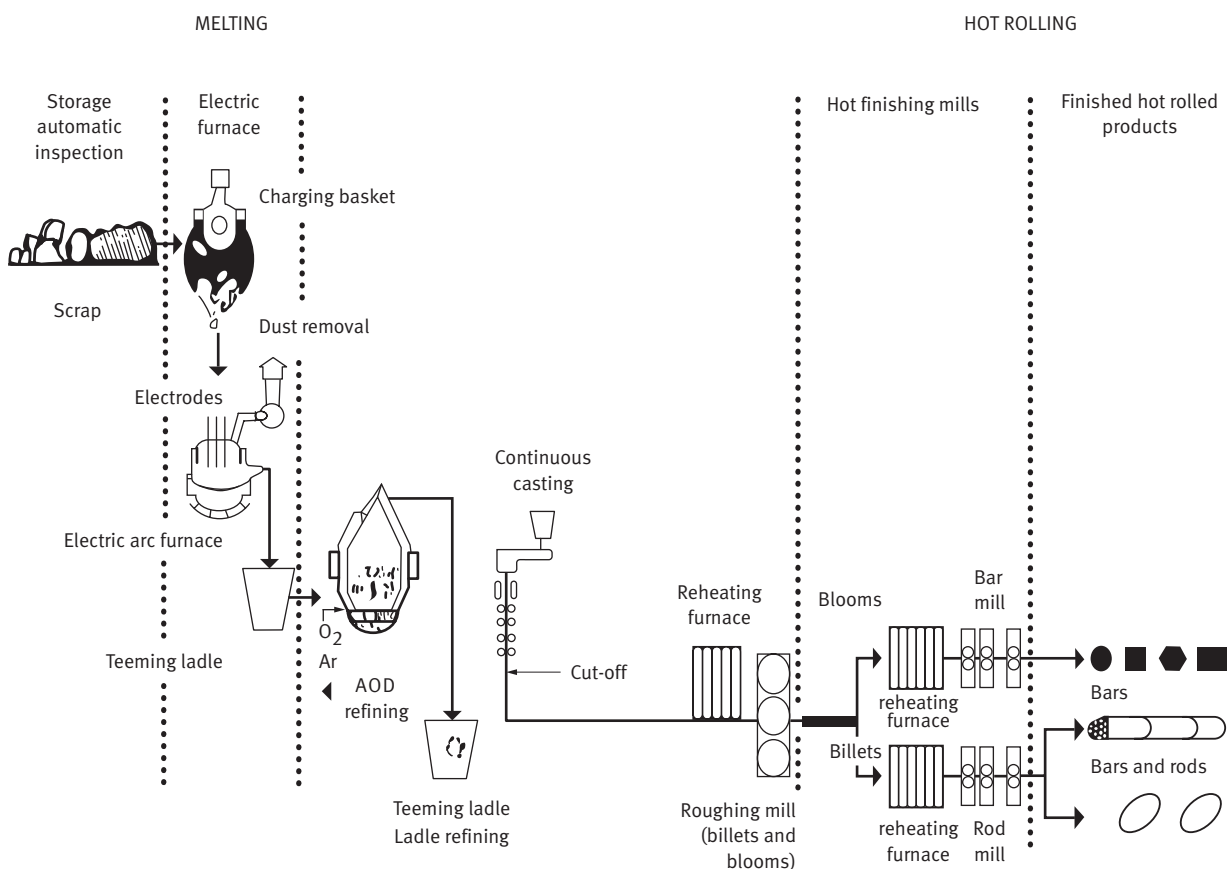

Tubes

The largest category of tubes corresponds to those produced by the continuous welding of strip. The major applications are for the transport of fluid (“corrosion” tubing), for decorative purposes (“decorative” tubing) and as structural elements.

Corrosion tubing is generally continuously welded using the TIG (tungsten inert gas) process, or the plasma or laser processes for thicker gages. These tubes are practically always circular in section.

Decorative tubing, on the other hand, can have either circular, square or rectangular sections. The tubes are welded either

by one of the three processes mentioned above or by the high frequency induction technique. After welding, they are generally polished.

A very wide range of standardized dimensions are available, the commonest ones being:

- for round sections: 10 to 168.3 mm outside diameter, 0.5 to 2.0 mm thickness;
- for square sections: 12 to 80 mm side length, 1.0 to 2.0 mm thickness;
- for rectangular sections: large side length 20 to 100 mm, small side length 6 to 40 mm, 1.0 to 2.0 mm thickness.

2 Working with stainless steels

2.1 Cutting – thermal cutting

The term “cutting” is used here to describe all the different methods employed to obtain sheets or blanks for subsequent forming and/or joining (e.g. by welding) to produce a more complex structure. Cutting can

be performed either mechanically, by techniques such as shearing, punching, nibbling, sawing, etc., or thermally, using a plasma torch or a laser beam, for example.



Photo 4: Hydraulic guillotine shear

Shearing

Straight-blade shearing

The capacity of straight-blade shears is generally given for mild steel. Since larger shearing forces are necessary for stainless steels, particularly the austenitic grades (Fe-Cr-Ni alloys), the maximum permissible thickness for a given machine is about 70% of that for mild steel. For example, a straight-blade shear capable of cutting 5 mm thick mild steel sheet will be limited to thicknesses not greater than 3.5 mm in the case of stainless steels (fig. 2.1.1).

The clearance between blades must be about 4 to 7% of the sheet thickness, with

a tolerance of ± 0.01 mm. When shearing is to be performed close to the edge of a sheet, this rule must be applied very strictly. Greater tolerance is possible for cutting in mid-sheet. For 1.5 mm thick sheet, the recommended clearance is 0.07 mm. For thicknesses larger than 1.5 mm, a clearance of the order of 0.1 mm represents a good compromise. The cutting or rake angle between the plane of the sheet and the blade end face can vary from $0^{\circ} 30'$ to 2° , a value of $1^{\circ} 30'$ being frequently employed.

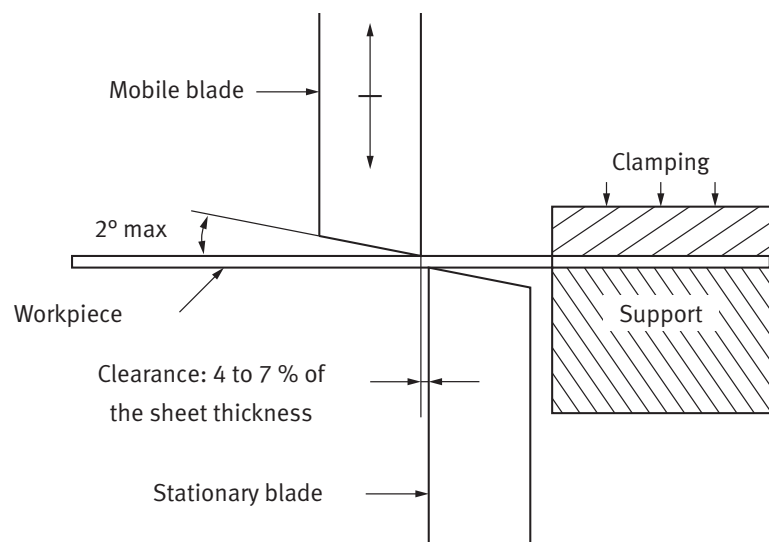

Fig. 2.1.1 - Mechanics of straight-blade shearing

The materials recommended for the shear blades are either quenched tool steels or chromium alloy steels. In order to increase their life between sharpening operations, they should be slightly lubricated with paraffin wax or a high viscosity oil.

In common with all operations involving the contact between a tool and stainless steel, it is imperative to use blades dedicated exclusively to the cutting of these materials, in order to avoid all risk of contamination, particularly by iron-rich particles.

When sheet is sheared to obtain narrow strips, their width must be at least 30 times the thickness. Thus, for a 1 mm thick sheet, the minimum permissible strip width will be 30 mm.

With regard to the shearing equipment, care must be taken to prevent the blankholder from damaging the sheet surface (scratches, indentations, etc.). Particularly in the case of thin sheets, the clamp jaws should be coated with elastomer.

Slitting

Slitting consists in cutting coiled stock into a number of narrower strips. A typical application of this process is the production of strip for the manufacture of welded tubes (the strip is formed into a multiple roll forming system and the edges are welded together longitudinally). In order to obtain a satisfactory cut, the horizontal clearance and vertical overlap of the circular slitting blades must be appropriately adjusted. A cold worked austenitic stainless steel or an as-quenched martensitic grade requires a small ratio between the vertical overlap and the strip thickness. An average value for the horizontal clearance

After shearing, examination of the cut edge is a good means of inspection. If the clearance is correct, the smooth upper part of the cut, corresponding to the blade penetration, should represent about 40% of the thickness, the lower fractured or torn portion making up the remaining 60%. If the clearance is too small, the fractured zone will cover the whole of the edge area, while if it is too large, the metal flows between the two blades, leading to a burr, with excessive local strain.

is 5% of the strip thickness. Depending on the stainless steel grade and the strip thickness, slitting speeds vary from 60 to 200 m/min. A sharp edge must be maintained on the circular blades to prevent burr formation at the cut edges of the strip. In order to increase blade life, it is recommended to use a soluble oil or paraffin-based lubricant. The materials recommended for the blades are the same as for straight blade shearing.

Fig. 2.1.2 - Press punching of rectangular blanks

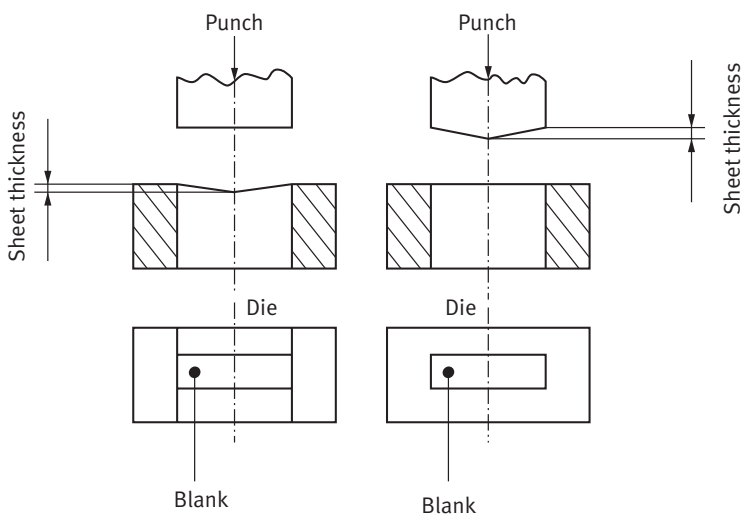
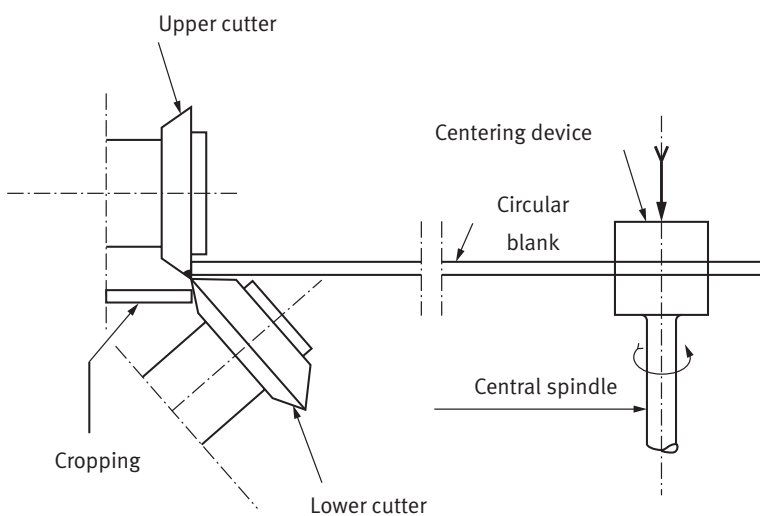

Fig. 2.1.3 - Rotary shearing



Blanking

Press punching

The blanking of stainless steels requires more powerful presses than for mild steels. In order to facilitate cutting, either the punch or the die can be machined at an oblique angle to create a difference in axial length between the center and the edge approximately equal to the sheet thickness. The clearance between the punch and the die must be between 5 and 10% of the work-piece thickness (fig. 2.1.2).

Rotary shearing

As in the case of slitting, the rotary cutters must overlap. This process is used for cutting out large diameter circular blanks for tank bottoms or large stampings. The maximum diameter that can be produced is about 2 m, for thicknesses up to 4 mm. The clearance usually employed is of the same order as for slitting. For the production of circular shapes, the cutting point is guided by a centering device placed in the middle of the blank. The imprint left by the clamping of this centering system must be subsequently eliminated, or better, avoided by using a suction pad (fig. 2.1.3).

Nibbling

Nibbling is a mechanical cutting technique in which material is removed along a path whose width is determined by that of the tooling. The latter is composed of a reciprocating punch which moves in and out of a fixed die, rejecting a crescent-shaped cropping at each stroke. In fact, nibbling is a repetitive punching process, in which the pitch between successive strokes is adjusted as a function of the sheet thickness. A precise cutting path can be followed by using a template guide or a numerical control system. The edges of the cut blank

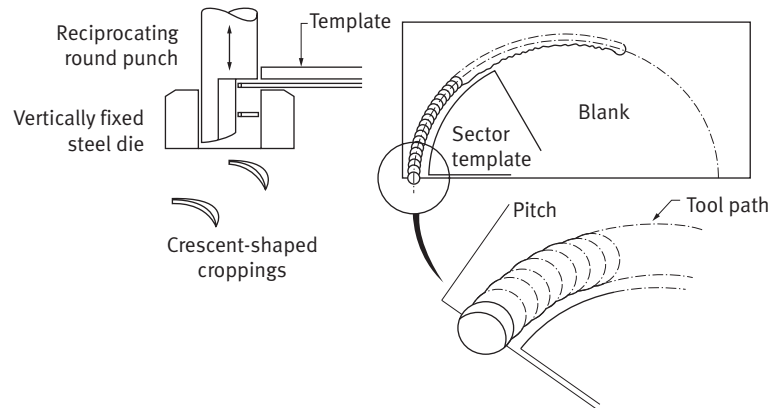

show the marks of the successive punch strokes, which are generally removed by fine grinding (fig. 2.1.4).

Fig. 2.1.4 - Nibbling

Piercing and perforating

Piercing and perforating are commonly used for cutting holes in sheet, the minimum diameter being twice the sheet thickness, with a minimum distance between adjacent holes equal to half the diameter. The forces necessary to pierce stainless steels are significantly higher than those for mild steel and are approximately in the ratio of the respective ultimate tensile strengths. In addition to the type of steel, these forces also depend on the effective clearance between the punch and die, on the number of holes punched simultaneously, and on the punching speed (fig. 2.1.5).

The clearance C between the punch and the die is the difference between their diameters, respectively d and D , and is therefore given by $C = D - d$. For routine work, the clearance is defined by the relation $C = 0.12 t$, where t is the workpiece thickness, while for "precision" piercing, a smaller clearance must be used, corresponding to

$C = 0.07 t$. Pierced holes always show a certain degree of conicity, which increases with the sheet thickness.

The lubricant must be chosen not only to facilitate cutting, but also to prevent the slug from sticking to the tooling.

Lever-operated manual piercing machines are limited to thicknesses of 2 mm and have very low productivity. Mechanical piercing presses are often equipped with quill punches, generally with a guide bushing. Numerically controlled piercing machines offer considerably improved productivity and ensure excellent precision in hole positioning (of the order of ± 0.03 mm). The punch relief angle is a maximum of 3° .

Fig. 2.1.5 - Principle of piercing

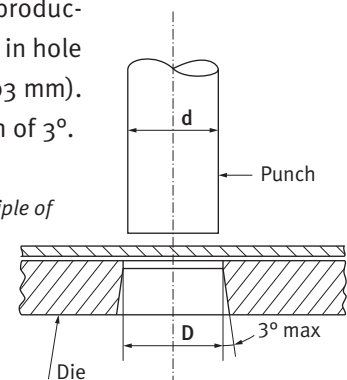

Sawing

Manual sawing

Stainless steels can be readily cut with a hacksaw. Contact between the blade and the metal must be during the push stroke, and it is recommended to lift the saw or lighten the

pressure during the return stroke to avoid work hardening. The maximum rate is of the order of 50 strokes per minute for blades with between 7 and 12 teeth per centimeter.

Power hack sawing

Power hack saws have reciprocating vertical blades. For stainless steels, short fine-toothed blades are employed. The maximum

sheet thickness which can be cut in this way is about 2.0 mm.

Milling cutter sawing

This technique is used for precision cutting, particularly of shaped sections and tubes. The tool is a milling cutter a few millimeters thick. In order to enable cutting at different angles, the toolholder must have a variable orientation. The surface of stainless steel sections must be protected to prevent them from being damaged by the clamping sys-

tem. In order to avoid the deformation of thin sections, wooden cores of appropriate shape should be placed inside them. The productivity of the process can be increased if the profile of the cut enables several sections or tubes to be mounted together.

Abrasive disk cutting

This technique is mainly employed for field cutting operations, and can only be used for short cuts. The pressure exerted by the disk should be limited to minimize heating and avoid oxidizing the workpiece. If this is

not possible, a local pickling and passivation treatment must be performed along the edges of the cut.

Band sawing

Band sawing is the most common cutting technique and is well adapted for straight cuts in metal thicknesses from 0.8 to 8 mm.

Depending on the thickness and the grade of stainless steel, the band speed varies from 15 to 40 m/min. The highest speeds are

used only for thin gage sheet, the speeds for thicknesses greater than 1.5 mm being limited to the range 15–30 m/min. Use of a lubricant is not necessary, but compressed air must be blown permanently onto the cutting zone to eliminate swarf and prevent excessive heating. In order to increase productivity, thin blanks can be stacked together and cut simultaneously.

Bandsaw cutting is also well adapted to the cutting of bars, giving a higher

productivity than with a reciprocating saw. In this case, the band speed can range from 30 m/min for the common austenitic alloy X5CrNi18-10/1.4301 to 40 m/min for the free-machining austenitic grade X10CrNiS18-09/1.4305, and up to 45 m/min for the free-machining ferritic grade X10CrS17/1.4104.

Water jet cutting

In this method, a high pressure water jet (2000 to 5000 bars) containing 0.2 to 0.5 mm abrasive particles of garnet or corundum is projected through a calibrated nozzle perpendicular to the surface of the workpiece, and is displaced laterally at a speed of the order of 20 cm/min. The water jet has a small diameter, and due to its high velocity, two to three times the speed of

sound, the resulting cut is of excellent quality. The process can be readily automated and its flexibility makes it well suited to small series cutting operations. When used for stainless steel sheet, it is recommended to cut stacks about 10 mm thick in order to improve productivity, since the cutting speed is not proportional to the thickness.

Thermal cutting

Oxygen-acetylene torch cutting

This process is mentioned only for the sake of completeness, being poorly adapted to the cutting of stainless steels, since it produces considerable oxidation and a large heat affected zone. However, it may sometimes represent an emergency solution. In contrast, powder-assisted oxyfuel cutting is

commonly used in steelworks for continuously cast stainless steel slabs, typically about 200 mm thick. In this case, surface oxidation and metallurgical transformations in the heat affected zone are not important.

Plasma-arc cutting

Fig. 2.1.6 - Principle of plasma - arc cutting

In this technique, the metal is melted locally due to the very high temperature (10000 to 20000 °C) of a confined plasma jet (fig. 2.1.6).

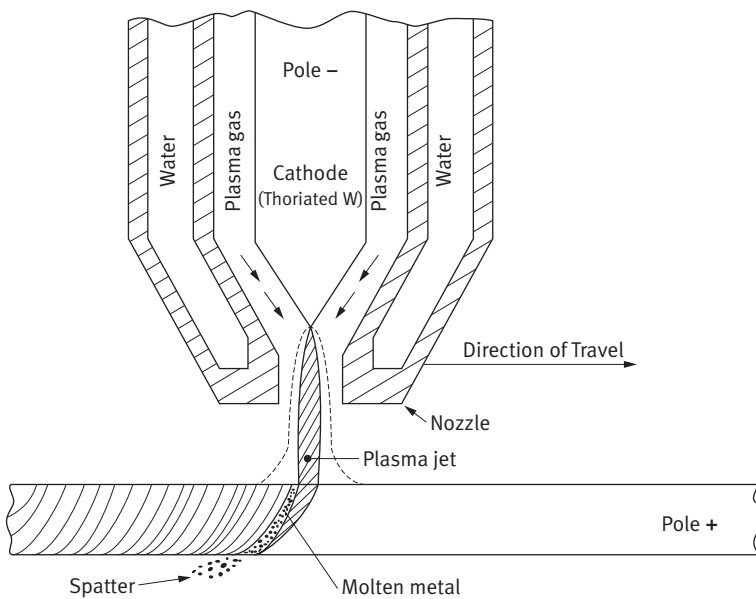

The plasma is a strongly ionized gas, the most common sources being argon, argon-hydrogen mixtures, nitrogen, and compressed air. Depending on the gas employed and the type of stainless steel, the degree of oxidation and edge contamination can vary. Simple grinding to a depth of about 0.5 mm is generally sufficient to remove the heat affected zone. When cutting is performed under water, oxidation is reduced and significantly higher speeds are possible. For 3 mm thick austenitic stainless steel sheets, the typical cutting speed is about 3.5 m/min. Compared to the mechanical cutting processes, with the exception of nibbling, the metal loss is higher. Moreover, the cut is not perpendicular, but has a slight relief angle, whose elimination requires further grinding in addition to that necessary to remove the heat affected zone.

Laser beam cutting

Fig. 2.1.7 - Principle of CO₂ laser beam cutting.

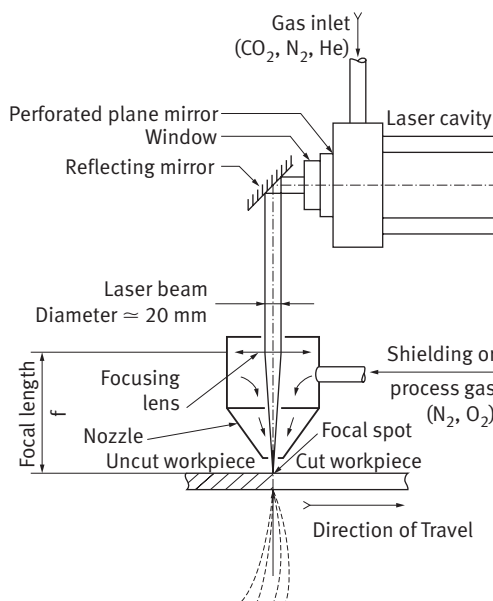

A laser is a device which produces an intense beam of light (LASER = Light Amplification by Stimulated Emission of Radiation). Like in the case of welding, two types of sources are employed for cutting, namely CO₂ lasers, in which the emitting medium is a CO₂-N₂-He mixture, and YAG lasers (yttrium-aluminum garnet). Laser beam cutting is performed either in the continuous emission mode, which allows high speeds to be attained, or in the pulsed mode, which limits the width of the heat affected zones. With CO₂ lasers (fig. 2.1.7), the power levels available range from 0.5 to 3 kW, while YAG lasers are limited to 2 kW, restricting their cutting speeds.

Whatever the laser source, the beam must be transported to the workpiece using either a mirror-based optical guide system (CO₂ lasers) or an optical fiber (YAG lasers). In order to cut the metal, the energy must be concentrated by a focusing system designed to produce a focal spot of diameter d given by $d = \lambda \times f/D$, where λ is the wavelength of the light (10.6 μm for a CO₂ laser), f is the focal length and D is the diameter of the parallel beam before focusing (typically about 20 mm for a CO₂ laser). The depth of field of the focal spot is proportional to $\lambda \times (f/D)^2$. Analysis of these two relations shows that a small focal spot requires a short focal length (f), whereas a long focal distance is required to obtain a large depth of focus. In practice, it is therefore necessary to strike a compromise between either a short (60 mm) or a long (300 mm) focal length. For example, a focal length of about 150 mm gives a focal spot diameter of approximately 0.3 mm and a depth of field slightly less than a millimeter.

Because of their relative performances, it is mainly CO₂ lasers that are used for cutting, the emitting medium being in fact a mixture of 40–80% helium, 15–55% nitrogen and 3.5–7% carbon dioxide. In addition to the “lasing” gas, a shielding or process gas (nitrogen or oxygen) is injected concentrically around the beam through a nozzle and is used to expulse the molten metal. When oxygen is employed, it reacts exothermically with the metal, enabling the use of higher cutting speeds. In order to obtain a good quality cut, the laser beam must be well centered in the nozzle and focused either

on the top surface of the workpiece (thin sheet) or at a depth of about a third of the thickness (thick sheet). Table 2.1.1 shows the performances obtained with a 1.5 kW CO₂ laser, used to cut 18% Cr – 9% Ni austenitic stainless steel sheet. When nitrogen is used as the process gas, a high quality cut is obtained, but at the expense of a lower cutting speed.

Finally, it should be pointed out that laser beam cutting is well adapted for cutting, not only flat sheets, but also shaped sections, such as short tubes. Since the laser beam is fixed, a tube section held in the hand of a robot can easily be cut along a complex profile. Obviously, such automatic operations can be envisaged only for sufficiently large series.

For example, this process is employed by certain automobile exhaust manifold manufacturers.

Sheet thickness (mm)	Cutting speed (m/min.)
Process gas = oxygen	
1,0	9,0
2,0	5,0
3,0	3,0
6,0	1,5
Process gas = nitrogen	
1,0	8,0
2,0	3,5
3,0	2,0
6,0	0,5

Table 2.1.1 - Cutting speeds obtained with a 1.5 kW CO₂ laser for 18% Cr-9% austenitic stainless steel sheet

2.2 Machining

Introduction

Among the numerous techniques employed for working stainless steels, machining processes mainly concern long products, although drilling, milling and tapping are frequently performed on flat products. In the latter case, these operations often precede mechanical joining with screws, bolts or rivets. In general, machining is a shaping process in which material is removed with the aid of a cutting tool. The facility with which this can be done depends among other things on the workpiece material. This has given rise to the concept of machinability, applied to a material or family of materials.

In the case of stainless steels, machinability was for a long time considered to be of secondary importance, since these materials were reputed to be difficult to machine, particularly the austenitic grades. However, steelmakers have endeavored to control this property and have succeeded in develop-

ing free-machining stainless steel grades, of which two types are presently distinguished:

- resulturized free-machining grades;
- “controlled oxide-treated” free-machining grades, whose machinability is improved by a controlled distribution and chemical composition of AlSiCa oxide inclusions. The “controlled oxide” treatment can be applied on “low sulphur” grades (up to 0.03% S according to the standards) or on resulturized grades in order to increase the synergism between the two free-machining methods.

In both cases, close control of the chemical composition and refining process ensures the presence of non-metallic inclusions that promote chip break-up and create a lubricating layer at the tool/chip interface during machining.

Machinability criteria

A large number of factors can affect machinability, but for practical reasons, only those that can be readily observed or measured will be considered, such as chip break-up, tool life, as-machined surface quality

(roughness) and power consumption. The productivity will then depend on the cutting conditions and on the ranking of the workpiece material with respect to these different criteria.

Behaviour of the different types of stainless steel

Austenitic stainless steels

These grades have high strain hardening rates, and in the cold worked condition their strength tends to induce rapid tool wear. However, even when heavily cold worked, their ductility is sufficient to cause the formation of long chips which tend to stick to the tool. This can result in the formation of a built-up edge on the tool (sticking phenomenon) that can increase the cutting loads on the tool and as a consequence the risk of tool fracture. High cutting loads are therefore required, leading to rapid tool wear,

with the risk of fracture due to damage to the cutting edge. Furthermore, the thermal conductivity of these alloys is about three times lower than for plain carbon steels, leading to a high work-piece/tool interface temperature which reduces tool life. For all these reasons, austenitic grades intended for machining generally have controlled sulfur contents of between 0.15 and 0.35%. However, in the remainder of this chapter, these materials will be considered as “normal” or “regular” grades.

Ferritic stainless steels

Ferritic alloys strain harden much less than the austenitic grades, the Ultimate Tensile Strength increasing by only about 200 N/mm² for 50% cold work, compared to more than 1000 N/mm² for certain austenitics. However, even though their thermal conductivity is higher and their strain

hardening lower than for austenitic alloys, the tendency to form long chips and the risk of sticking remain high. Ferritic stainless steels destined to be machined are therefore almost always resulfurized (cf. the section “Sulfide inclusions”, resulfurized free – machining steels).

Martensitic stainless steels

The strain hardening behaviour and thermal conductivity of these grades are similar to those of low alloy steels, particularly structural steels. However, since they are

usually quenched and tempered, they have very high strength, inducing high cutting loads.

Effect of non-metallic inclusions

Sulfide inclusions – resulfurized free-machining steels

The deliberate use of high sulfur contents, typically in the range 0.15 to 0.35%, is a well established technique which produces a spectacular improvement in machinability. The addition of sulfur causes the formation of manganese sulfides whose beneficial effect on machinability has been clearly demonstrated. In contrast, their presence markedly reduces the corrosion resistance, particularly under conditions conducive to pitting. Furthermore, excessive sulfur levels impair both hot workability and weldability, due to an increased risk of hot cracking (mainly for austenitic alloys). For this reason, metallur-

gists have sought other mechanisms for improving machinability (cf. the section “Oxide inclusions”). High sulfur free-machining versions are available for the three families of stainless steels, austenitic, ferritic and martensitic, and are the most widely used grades for machined components. Their standard designations are as follows:

- X8CrNiS18-9 / 1.4305 and X6CrNiCuS18-9-2 / 1.4570 (austenitics);
- X6CrMoS17 / 1.4105 (ferritic);
- X12CrS13 / 1.4005 and X29CrS13 / 1.4029 (martensitics).

Oxide inclusions

It is well known that hard oxides, such as those rich in alumina (Al_2O_3), silica (SiO_2) or chromite (Cr_2O_3), do not deform and conserve their hardness up to very high temperatures. Inclusions of this type, which are frequently present in standard stainless steels, are therefore highly abrasive and strongly reduce the life of cutting tools. If, on the other hand, the melting and refining practice is modified so as to obtain mixed SiO_2 -CaO- Al_2O_3 oxides, which are malleable at high temperatures, then the inclusions are able to deform during machining, becoming heavily elongated in the shear

zones of the chip, facilitating its break-up. Moreover, they form a lubricating layer at the tool surface, limiting heating and wear. Alloys of this type have been developed both for long and flat products. For example, compared to the equivalent standard grade, a well-done “controlled oxide” treatment on an X5CrNi18-10/1.4301 leads to a productivity improvement of the order of 25% for turning operations. Finally, unlike the resulfurized grades, with this family of alloys, the improvement in machinability is not obtained at the expense of corrosion resistance, which remains strictly unaffected.

Synergism between the effects of sulfur and malleable oxides

If the two mechanisms for enhancing machinability in stainless steels are combined (sulfur

additions and “controlled oxide” treatment), there is found to be a synergism between

them that can lead to an increase of the machinability as high as 50% with “controlled

oxide” X8CrNiS 18-9/1.4305 compared to the standard grade.

Choice of tools

The appropriate choice of tools is of paramount importance for the machining of stainless steels, and directly determines the productivity. Four different categories of materials can be distinguished:

- Coated and uncoated high speed steels (HSS);
- Coated carbide inserts;
- Cermets;
- Ceramics, silicone-fiber reinforced inserts.

In general, high speed steels are used for drilling and threading, while coated carbide inserts are used for turning and milling (face milling) of stainless steels at higher cutting speed. The coatings most frequently used are made of titanium nitride (TiN), titanium carbonitride {Ti(C,N)} and alumina oxide (Al₂O₃). Coatings can be applied by two processes:

- Physical Vapor Deposition (PVD) ;
- Chemical Vapor Deposition (CVD).

PVD coatings are applied to the substrate at low temperatures. This process preserves edge strength and permits coating of sharp edges. PVD coatings have a smooth surface that generates less frictional heat, allows lower cutting forces and resists edge build-up that can lead to sticking.

CVD coatings are applied to the substrate at high temperatures. This process causes a diffusion of the coating in the substrate to assure a strong bond. The CVD process also permits deposition of multi-layer coatings that can suppress both crater wear and flank wear, thereby expanding the range of tool application. CVD is currently the only coating proc-

ess that can efficiently apply alumina (Al₂O₃), which permits high cutting speeds. The TiN coating, which usually is applied on top, is golden yellow (making the corresponding tools and inserts readily recognizable), while the others are black or grey.

The word cermet is derived from the terms CERamic and METal. Cermets consist mostly carbonitride Ti(C,N) sintered with a metallic phase (Co, Ni, Mo,...) which acts as a binder. Cermets have in the past had a reputation of exhibiting poor thermal and fracture toughnesses.

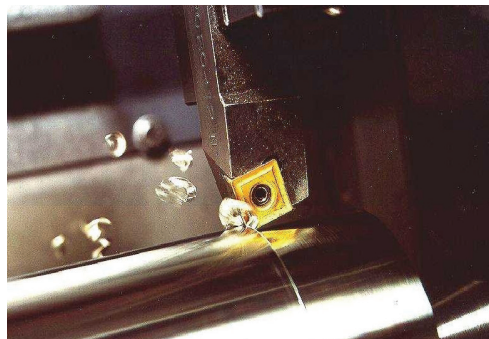

Photo 5: Coated carbide insert used in rough turning

Photo 6: Coated CERMET insert used in finish turning

Recently, new micrograin cermet grades were developed which provide greater thermal toughness and the ability to handle higher cutting speeds (up to 900 m/min). The cermets are principally used for finishing operations. They give an excellent surface, often avoiding the need of finish grinding. They are also ideal to maintain tight tolerances.

Ceramics could previously not be used for stainless steels, but the development of silicon fibre for reinforcement of the inserts have resulted in machining high alloyed stainless steels.

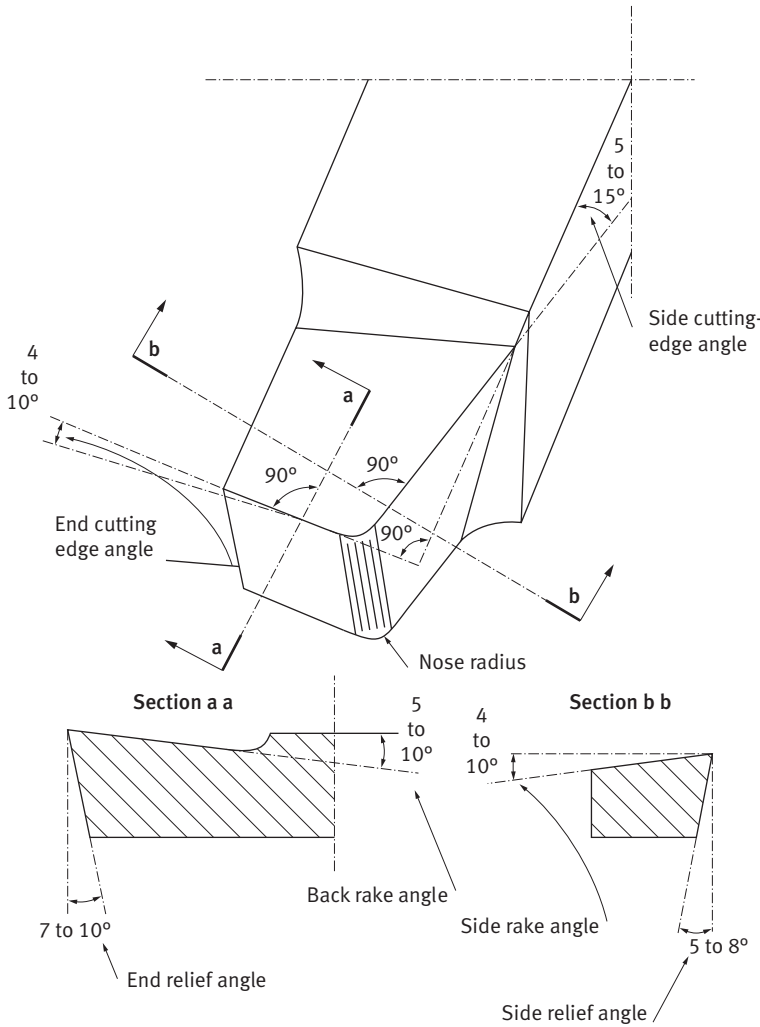

Fig. 2.2.2 - High speed steel drilling bit

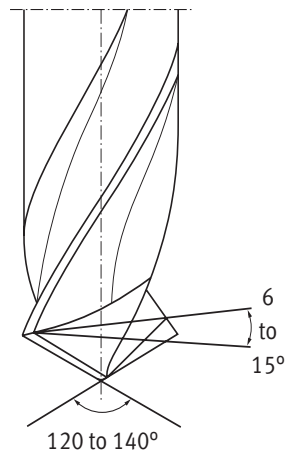

Table 2.2.1 gives typical cutting speeds possible for the machining of stainless steels with different types of tools.

Lathe turning

When turning stainless steels, the workpiece and tool must be held much more rigidly than for plain carbon steels. Depending on the stainless steel and the coated carbide grades, the cutting speed should be in the range 75–750 m/min, with feed rates of 0.1 to 0.3 mm per revolution (mm/rev). The higher speeds can be used with CVD coated carbide tools cutting “resulfurized” and “controlled oxide treated” grades. For rough turning, the cutting speed should be reduced and the feed rate increased, and vice versa for finish machining. Typical tool geometries are given in figure 2.2.1, the exact values depending on the nature of the tool material.

Drilling

Drilling is used in long products, thick sheets and strips, and plates. If it is applied on thin sheets, it is preferable to stack several of them together or to have solid support underneath. Small diameter drilling bits (diameter \leq 6 mm) are generally made from high speed steels, intermediate diameter ones from solid (coated) carbides, and larger diameter ones (diameter \geq 15 mm) are made from carbide inserts. For long products and thick sheets or plates, the point angle is of the order of 120 to 135°, with a relief angle of about 6°. For thin sheets, in order to reduce surface stresses, the point angle can be increased to 140° and the relief angle reduced to 5° (fig. 2.2.2). The rotational speed of the bit

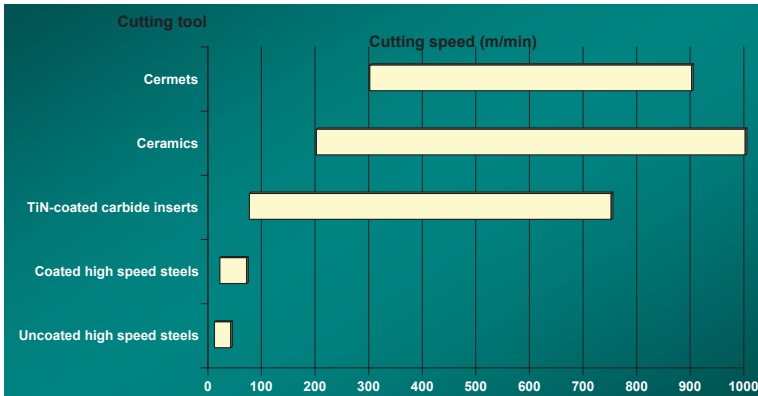

Table 2.2.1 - Range of stainless steel turning speeds possible with different types of tools

(cutting speed) depends on the workpiece material and the type of tool employed, typical values being given in Table 2.2.2.

For the drilling of deep holes, it is recommended to begin with a short bit, and it is important to allow the lubricant to reach the drill tip and to eject the chips by the drill flutes thanks to lubricant channels in the bit and high lubricant pressures ($p \rightarrow 20$ bars). In order to

avoid strain hardening the workpiece surface, it is not recommended to use the drill to mark the center point. A self-centering drill or a template should be used for this purpose.

Large diameter holes are produced by trepanning, in which a circular groove is cut, leaving an unmachined core. The tool comprises one, two, or three adjustable cutting edges, and is generally equipped with a centering guide to avoid the need to drill a starting hole.

Boring and reaming

Two types of operation can be used for enlarging previously formed holes, namely boring and reaming. Boring uses simple coated or uncoated carbide cutting tools or inserts. In order to avoid problems of vibration and conicity, the unsupported bar length should

be limited to not more than four times its diameter. The cutting speeds employed are significantly lower than for turning, for the same depth of cut. As a general rule, a cutting speed reduction factor of about 0.5 is applied for normal stainless steels and 0.67 to 0.75 for

Table 2.2.2 - Cutting speeds for different stainless steels as a function of drill diameter.

Workpiece material	Drill diameter 3 mm		Drill diameter 6 mm		Drill diameter 12 mm		Drill diameter 18 mm	
	Cutting speed ⁽¹⁾ m/min	Feed ⁽¹⁾ mm/rev	Cutting speed ⁽¹⁾ m/min	Feed ⁽¹⁾ mm/rev	Cutting speed ⁽¹⁾ m/min	Feed ⁽¹⁾ mm/rev	Cutting speed ⁽¹⁾ m/min	Feed ⁽¹⁾ mm/rev
X5CrNi18-10 / 1.4301	16	0.09	18	0.11	20	0.15	22	0.18
“COT” ⁽²⁾ X5CrNi18-10 / 1.4301	20	0.09	22	0.11	25	0.15	28	0.18
“COT” ⁽²⁾ X8CrNiS18-9 / 1.4305	26	0.17	32	0.20	37	0.24	40	0.30
“COT” ⁽²⁾ X14CrMoS17 / 1.4104	35	0.30	38	0.35	43	0.42	50	0.50
X2CrNiMoN22-5-3 / 1.4462	14	0.09	16	0.11	18	0.15	20	0.18

⁽¹⁾ Cutting parameters to drill over 15 m without changing the tool

⁽²⁾ COT : “Controlled Oxide Treated”

$$\text{Rotational speed (revs/min.)} = \frac{1000 \times \text{Cutting speed (m/min)}}{\pi \times \text{drill diameter (mm)}}$$

free-machining grades. The same feed rates as for turning can be used for a given depth of cut, provided that the unsupported bar length is less than four times its diameter. If this is not the case, a reduction coefficient of 0.67 should be applied to the feed rates employed in turning.

For reaming, high speed steel reamers with helical or straight flutes are usually used for the finishing pass. The rake angle is between 3 and 8°, while the relief angle is about 7°. Hand

reamers are generally tapered slightly at the end, while machine reamers also have a chamfer of about 40°. For free-machining stainless steels, the cutting speed is identical to that used for drilling with a high speed steel bit. For normal grades it must be reduced by a factor of 0.67 or even 0.5 compared to that for drilling. The feed rates depend mainly on the reamer diameter. They are generally of the order of 0.10 to 0.20 mm/rev for a diameter of 3 to 4 mm and 0.3 to 0.5 mm/rev for diameters of 8 to 12 mm.

Milling

Because of the generally high cutting forces, powerful machines are necessary, and it is important to eliminate backlash, particularly for climb milling or down milling. As for turning, it is recommended to use coated carbide tools or inserts. For carbide end milling tools, cutting speeds between 90 and 200 m/min are possible for free-machining grades and be-

tween 50 and 150 m/min for regular materials. Feed rates vary between 0.012 and 0.125 mm/rev/tooth, depending on the cutter diameter. For face milling equipped with carbide inserts, cutting speeds range from 80 to 400 m/min for free-machining grades and from about 50 to 300 m/min for standard alloys. Feed rates are between 0.05 and 0.20 mm/rev/tooth.

Tapping

Tapping is difficult for austenitic stainless steels, particularly in the case of small diameter holes. The tendency to form filamentary chips can cause tool failure. In order to limit this risk, three-flute taps should be used for small diameters,

and four-flute taps for larger diameters. The rake angles are generally between 10 and 15°, with cutting speeds varying from 5 to 30 m/min. Intense lubrication is necessary. The application of a high pressure facilitates chip removal.

Threading

Several methods can be used for machining threads:

- Single point thread cutting on a lathe with an indexable carbide insert or a high speed steel tool.
- Die or tap threading.
- Cylindrical die thread rolling.

For single point threading, the cutting speeds to be used are two thirds those for turning in the case of free-machining grades, and half those for turning for normal grades. For the other threading processes, the cutting speeds with high speed steel tools are between 5 and 25 m/min.

2.3 Cold forming

Bending

General aspects

The procedures and equipment used for bending stainless steels are similar to those for mild steel. However, the power necessary to bend austenitic grades (i.e. those containing significant amounts of both chromium and nickel) is 50 to 60% higher than for mild steels. Furthermore, since elastic springback is also greater in aus-

tenitic stainless steels, the bending angles must be significantly modified compared to those for mild steels. In the annealed condition, the minimum bending radius is equal to the sheet thickness, while for cold worked materials, the radius of curvature must be increased to about six times the thickness.

Protection of the surfaces of stainless steel sheets

All too often, stainless steel sheets with unprotected surfaces are bent in direct contact with the tooling (punch and die). Friction during bending causes scratching, or in the absence of slip, marks are created due to the imperfections on the tool surfaces. Such practice may be acceptable for invisible structural parts, but is not permissible for decorative components or those intended for food processing or chemical

engineering applications. In order to avoid damage to the sheet surfaces, it is recommended to place a sheet of rubber (latex) about 1 mm thick between the tool and the workpiece (fig. 2.3.1). Stainless steel sheets are increasingly supplied with a temporary adhesive protective film, which can be removed after bending, immediately before putting the equipment into service.

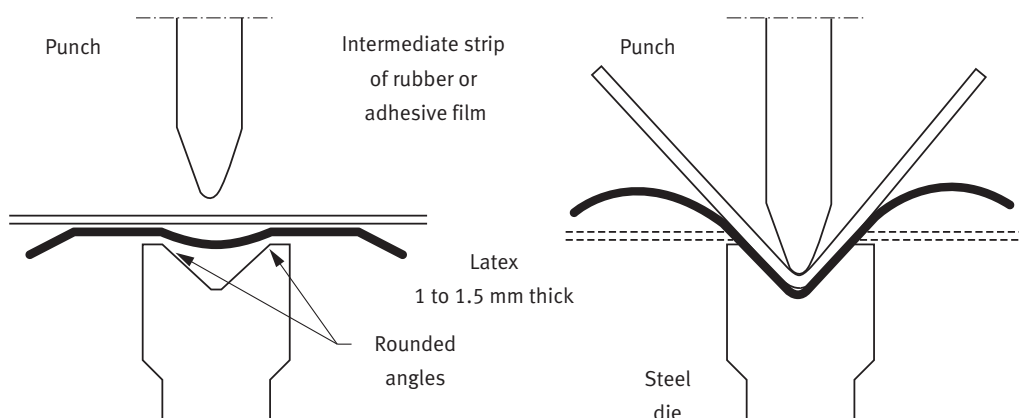

Fig. 2.3.1 - Bending with an intermediate strip of rubber to protect the surface that will be visible in use

Manual bending

Stainless steels can be bent without difficulty, provided that the inside bend radius

is not less than the thickness of the sheet concerned.

Mechanical press brake bending

Press brakes are perfectly suited to the bending of stainless steel sheet provided that elementary precautions are taken concerning their cleanness and the surface quality of the tooling. Press brakes are generally limited to useful lengths of 3 m and maximum thickness of the order of 3 mm.

They are convenient for producing variable section profiles. In principle, these machines cannot bend to sharp angles, the minimum inside bending radius being about twice the sheet thickness. While certain manual press brakes still exist, most of them are motor driven.

Hydraulic press brake bending

The use of hydraulic presses allows great flexibility and good regularity of bending. This type of machine is appropriate for bending sheets in various grades of stainless steel, for producing profiles, panels and walling. They are routinely employed for bending materials used for building and decorative applications. With tooling in good condi-

tion, with correctly protected surfaces, the results obtained are excellent. Four methods are commonly used for the hydraulic press bending of stainless steel sheets:

- open die bending;
- closed die bending;
- closed die bending with angle forging;
- rubber pad bending.

Open die bending

In this process, the sheet is supported on the die at two points between which the punch nose exerts a pressure (fig. 2.3.2). The punch does not press the sheet against the bottom or sides of the die, but stops at a predetermined distance. Depending on the bending angle, a U-shaped die is often chosen. It is necessary to allow for the elastic springback. With this method, it is possible to bend thick sheets to different angles with the same tooling, but the inside bend radius is always large and cannot be guaranteed.

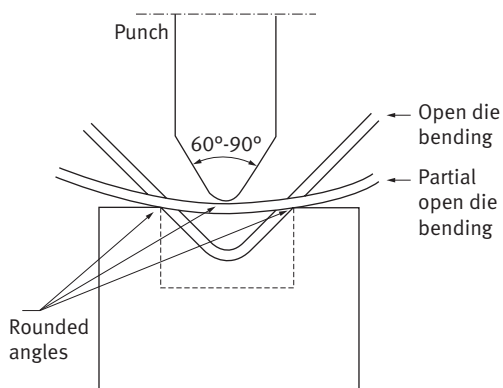

Fig. 2.3.2 - Principle of open die bending

Closed die bending

In this case, the punch or blade presses the sheet against the sides and bottom of the die, but without drawing strain, so that the workpiece adopts the shape of the tool. The inside bend radius is generally equal to the sheet thickness (fig. 2.3.3). This process requires machined tooling adapted to the desired bending angle and radius. For ex-

ample, in order to allow for elastic spring-back, a V-shaped die with an angle between 85 and 89° must be used for an effective bend angle of 90°. The opening at the mouth of the V must be 4 to 5 times the sheet thickness for thin gage sheet and 6 to 8 times the thickness for medium gages (about 2 mm).

Closed die bending with angle forging

In this method, bending is performed in two steps, the first of which corresponds to open die bending to obtain the desired angle. In the second step, the punch descends rapidly and sharply strikes the apex of the bend in order to deform it and reduce or eliminate elastic springback, the bending angle being that of the punch. This process can be used to accurately bend stainless steel sheets up to 1.5 mm thick. The inside bending radius can be as small as half the sheet thickness (fig. 2.3.4). However, the blow locally deforms the sheet and can even cause incipient necking, so that the bend is a point of weakness.

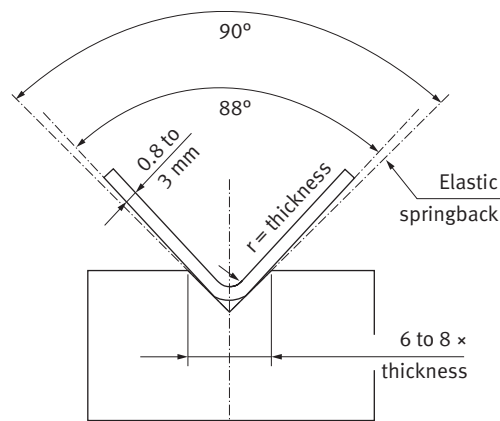

Fig. 2.3.3 - Closed die bending

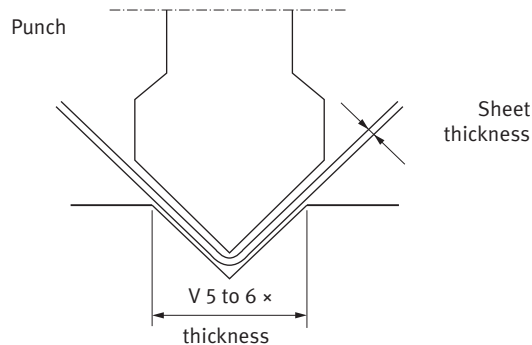
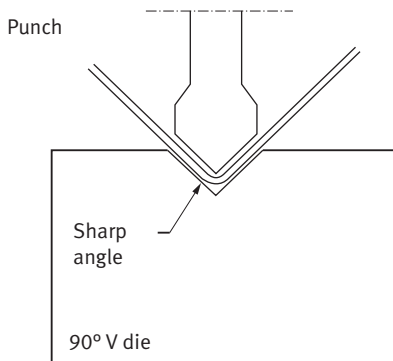

Fig. 2.3.4 - Closed die bending with angle forging

Rubber pad bending

For fine work, where the sheet surfaces must not be damaged, it is recommended to perform the bending operation in a die composed of a rubber pad of appropriate hardness (Shore). In fact, the rubber pad re-

places the conventional hardened steel die and enables the bending of complex parts and sections such as those used in decorative applications. This method can be employed for stainless steel sheet thicknesses generally between 0.4 and 1.5 mm and has two major advantages:

- a) it is possible to replace a large number of costly steel dies by a single rubber pad;
- b) the sheet surface in contact with the pad remains in perfect condition, avoiding the need for expensive subsequent polishing operations.

The possibilities offered by this method are illustrated in figure 2.3.5a for a V bend and in figure 2.3.5b for a circular section bend.

Fig. 2.3.5
a - V-bending on a rubber pad
b - Circular bending on a rubber pad

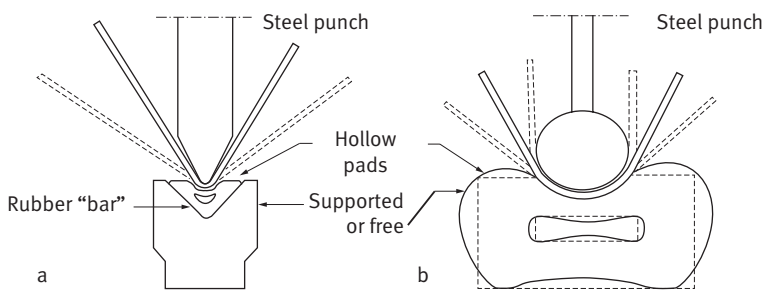

Calculation of the developed length of a profiled sheet

Since the metal flows freely during bending, the inner fibers are in compression and become shorter, while the outer fibers are in tension and are elongated. Only the neutral fiber does not change length and is

therefore used to calculate the developed area for medium and thick gage sheet. For thin sheets, less than 1 mm thick, the calculation is based on the innermost fiber.

Elastic springback

The degree of elastic springback depends on the grade of stainless steel concerned, its mechanical properties, particularly the amount of cold work, and on the geometry of bending, including the bend radius and angle and the thickness of the sheet. Based on these parameters, relations are available for determining the punch and die angles

necessary to produce a desired permanent bend angle after removal of the loads. For example, when the radius of curvature is equal to the sheet thickness, the tool angle must be 0.97 times the desired bending angle for the X5CrNi18-10 / 1.4301 grade in the annealed condition, the ratio being only 0.90 for the same material in the half hard condition.

Three-roll forming

General features

Three-roll forming machines are used to produce components such as cylinders from sheet. Machines designed for mild steels can

usually be employed for stainless grades, but their capacity will be reduced by about 30%.

The three-roll forming operation

Before rolling, the end of the sheet to be inserted in the machine is generally prepared by bending in a press using a cylindrical punch. In the pyramid type machines usually

employed, the cylinder radius is adjusted by an inner bending roll covering between $1/8$ and $1/6$ of the section. The developed area is calculated in the same way as for bending.

Drawing

Principle and theoretical basis

Drawing is a forming operation used to produce hollow objects from a flat sheet or blank. It is a complex process in which the metal goes through a number of states involving different combinations of tensile and compressive loading. The overall state of strain in a sheet element can be correctly described in terms of the strains in the three principal directions:

- in the “longitudinal” direction (parallel to the principal metal flow):
 $\epsilon_1 = \ln(l/l_0)$, where l_0 is the initial length of the element and l the final length;
- in the “transverse” direction, (in the plane of the sheet, perpendicular to the principal metal flow):
 $\epsilon_2 = \ln(w/w_0)$, where w_0 is the initial width of the element and w the final width;
- in the thickness direction:
 $\epsilon_3 = \ln(t/t_0)$, where t_0 is the initial thickness of the element and t the final thickness.

Since the volume is conserved during deformation, $\epsilon_1 + \epsilon_2 + \epsilon_3 = 0$.

Two principal modes of deformation are distinguished in drawing, namely biaxial expansion or stretching (fig. 2.3.6), which

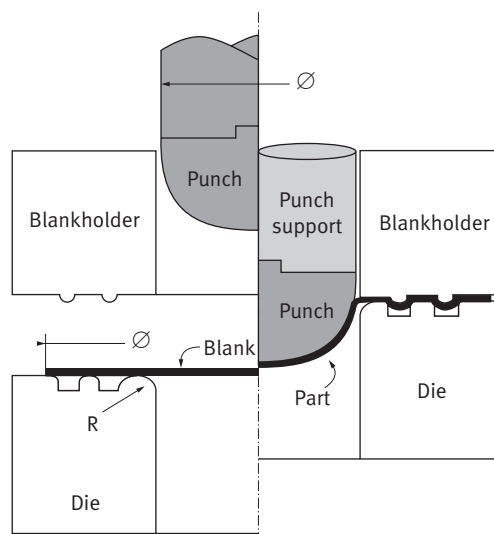

Fig. 2.3.6 - Stretching (biaxial expansion) forming mode: the blank is constrained between the die and the blankholder

occurs when the blank is constrained between the blankholder and the die, and drawing or plane strain compression (fig. 2.3.7), in which the metal is drawn inwards, slipping between the die and the blankholder to form the walls or skirt of the part. In the stretch-

ing mode, the cylindrical punch has a hemispherical nose, while in the drawing mode, the punch nose is flat. Figure 2.3.8 shows the principal deformation modes as they appear in the cups produced in various drawability tests (Swift, Erichsen, etc.).

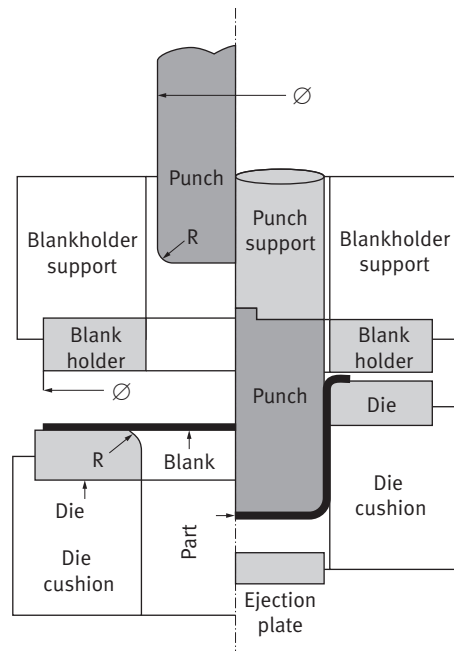

Fig. 2.3.7 - Deep drawing forming mode: the blank slips between the die and the blank-holder

The most faithful representation of the deformations in a part during and after forming is given by the corresponding true strains, which can be represented in a two-dimensional diagram whose orthogonal axes are the principal strains ϵ_1 and ϵ_2 . The region of stretching is defined roughly by the area between the lines $\epsilon_1 = \epsilon_2$ and $\epsilon_1 = -2\epsilon_2$. The region of drawing is defined approximately by the area between the lines $\epsilon_1 = -2\epsilon_2$ and $\epsilon_1 = -\epsilon_2/2$. In the drawing mode, the most significant feature is the increase in thickness ($\epsilon_3 > 0$) at the top of the skirt, whereas in the stretching mode, the metal tends to be thinned ($\epsilon_3 < 0$) beneath the punch nose.

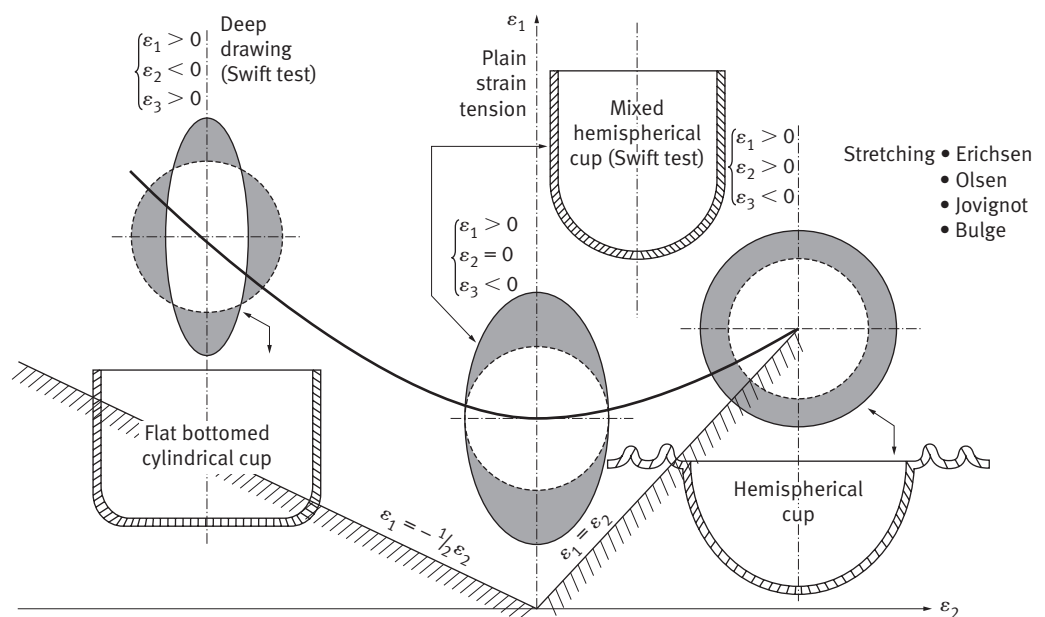

Fig. 2.3.8 - Principal deformation modes in drawing, illustrated by the different types of cupping test

In the Swift test, a circular blank is allowed to slip between the blankholder and the die due to the action of a 33 mm diameter flat nosed punch. This method is used to determine the limiting drawing ratio (LDR), which is defined as the maximum ratio between the blank diameter and the fixed punch diameter for which drawing can be completed without failure (LDR = maximum blank diameter/punch diameter). The results given in Table 2.3.1 were obtained for the grades considered previously.

Even though the overall drawing capacity of austenitic stainless steels (Fe-Cr-Ni alloys) is better than for ferritic grades (Fe-Cr alloys), the table shows the excellent performance of the titanium-stabilized 17% Cr alloy. For drawn parts of this type, this ferritic material can often be a useful substitute for more expensive austenitic grades.

The most widely used drawability techniques are the Erichsen test for the stretching mode and the Swift test for the drawing mode. In the Erichsen test, the blank is tightly clamped between the die and the blankholder and the metal is deformed until the onset of necking, which immediately precedes failure, at which point the drawing depth or “Erichsen deflection” is measured.

Table 2.3.2 gives the Erichsen deflections for the same grades, for an initial blank thickness of 0.8 mm. The superior performance of the austenitic grade X5CrNi18-10 in this deformation mode is clearly apparent.

From a more fundamental viewpoint, the aptitude of a stainless steel for forming can be deduced from its true stress-true strain curve $\sigma = f(\epsilon)$ determined by tensile testing. In particular, this curve reveals the strain

European designation: EN 10088-2		LDR (limiting drawing ratio)
Name	Number	
X6Cr17	1.4016	2.05–2.10
X3CrTi17	1.4510	2.15–2.25
X5CrNi18-10	1.4301	2.00–2.05

hardening behaviour, while the area beneath the curve represents the work expended to produce a given amount of deformation. The slope of the curve at any point corresponds to the strain hardening rate. The true stress-true strain curve is generally described by the relation $\sigma = f(\epsilon) = k\epsilon^n$. The exponent n is called the *strain hardening coefficient*, and is a convenient measure of the work hardening behaviour, since it is constant over a range of strain and can be determined from the slope of the $\ln \sigma = f(\ln \epsilon)$ curve. Furthermore, for tensile tests on flat specimens, in addition to the longitudinal deformation (ϵ_1), the true strain can be measured in the width (ϵ_2) and thickness (ϵ_3) directions, the latter two values showing a proportional relationship given by $r = \epsilon_2/\epsilon_3$, the parameter r being known as the strain ratio. It provides a good indication of the tendency of a sheet metal to thicken or thin during a forming operation. Thus, if $r < 1$, the metal will tend to thin rather than thicken, whereas the opposite will be true if $r > 1$.

The plastic strain ratio usually depends on the direction of the deformation with respect to the sheet rolling direction. In order to characterize the anisotropy of a sheet

Table 2.3.1 - Limiting drawing ratio (LDR) determined by the Swift test on 0.8 mm thick circular blanks

Table 2.3.2 - Erichsen deflections for 0.8 mm thick ferritic and austenitic stainless steel blanks

European designation: EN 10088-2		Erichsen deflection (mm)
Name	Number	
X6Cr17	1.4016	8.7
X3CrTi17	1.4510	9.6
X5CrNi18-10	1.4301	11.5

material, r is measured at angles of 90° , 45° and 0° to the rolling direction, and anisotropy coefficients are defined as follows:

- the normal strain ratio:

$$r_n = (r_o + r_{90} + 2 r_{45}) / 4$$

- the planar strain ratio:

$$\Delta r = (r_o + r_{90} - 2 r_{45}) / 2$$

The latter relation does not always correctly describe the behaviour of stainless steels, for which the following formula is often preferred

$$\Delta r = [(r_o - r_n)^2 + (r_{90} - r_n)^2 + (r_{45} - r_n)^2]^{1/2}$$

The normal strain ratio r_n gives a good indication of the aptitude for deformation in the drawing mode, while the planar strain ratio Δr

can be correlated with the height of the “ears” formed during drawing (fig. 2.3.9). In general, there is a quite good correlation between the strain hardening coefficient n , the normal strain ratio r_n and the results of Erichsen (stretching) and Swift (drawing) tests.

For forming operations where the major deformation mode is stretching, it is preferable to choose a material with a high n value. Conversely, when the drawing mode is predominant, the material should have a high normal strain ratio r_n . In fact, the parameters n and r_n are intrinsic overall characteristics of the material, whereas the critical phenomena during drawing occur locally (necking and fracture). The significance and usefulness of n and r_n are therefore only relative. They give a general indication of the deformation behaviour of different materials, and therefore of their drawability, but remain insufficient for analyzing a specific problem. Table 2.3.3 gives characteristic values of n , r_n and Δr for the major ferritic and austenitic stainless steel grades used for drawing.

The local phenomena mentioned above (necking, fracture) can have several causes. Some of them are related to microstructural parameters, such as the grain size, the dimensions and distribution of inclusions and/or precipitates, and the surface roughness which influences lubricant retention, etc. Other more technological factors often play a decisive role, the most important ones being the clearance between the punch and the die, the blankholder pressure, the punch and die radii, the nature of the tools and their surface quality, and finally, the type of lubricant.

Fig. 2.3.9 - Earing tendencies for different stainless steel grades

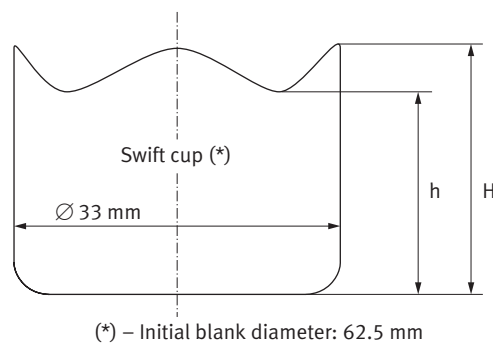

$$\text{Earing index}(\%) = \frac{H - h}{H + h} \times 200$$

European designation		Δr	Earing index (%)
Name	Number		
X6Cr17	1.4016	0.50	8 to 12
X3CrTi17	1.4510	0.35	4 to 6
X5CrNi18-10	1.4301	0.45	5 to 7

Table 2.3.3 - Normal and planar strain ratios and strain hardening coefficients for different grades

European designation: EN 10088-2				
Name	Number	r_n	Δr	n
X6Cr17	1.4016	1.1/1.6	0.50	0.20/0.25
X3CrTi17	1.4510	1.6/2.0	0.35	0.22/0.28
X5CrNi18-10	1.4301	1.0/1.3	0.45	0.50/0.70

Forming limit curves

The local deformations during and after forming are described in terms of the principal true strains, ϵ_1 in the longitudinal direction (sometimes denoted ϵ_r for radial strain in the case of circular parts), and ϵ_2 in the transverse direction (or ϵ_c for circumferential strain in circular parts). The various combinations of these two principal strains that lead to the onset of either necking or fracture can be plotted on a diagram, to give so-called forming limit curves. Figures 2.3.10 and 2.3.11 show such curves respectively for the 17%Cr ferritic grade X6Cr17/1.4016 and the 18% Cr-9% Ni austenitic alloy X5CrNi18-10/1.4301. Since only positive elongations are possible in drawing, only this part of the ordinate (ϵ_1) scale is shown. The ordinate axis separates regions of lateral expansion ($\epsilon_2 > 0$) and shrinkage ($\epsilon_2 < 0$). The principal strains ϵ_1 and ϵ_2 can be measured either from the overall dimensional changes of simple test specimens or, more generally, from the local deformation of grids printed on the surface of blanks prior to drawability tests. The grids used for measuring the principal strains are generally composed of overlapping 2 mm diameter circles, produced by electrochemical etching. Their dimensions are measured using an optical system of the profile projector type, at a ten times magnification. The forming limit curves shown in figures 2.3.10 and 2.3.11 are based on six types of tests, namely smooth and notched specimen tensile tests, and Erichsen, Olsen, Bulge and Swift cupping tests, using different lubricants.

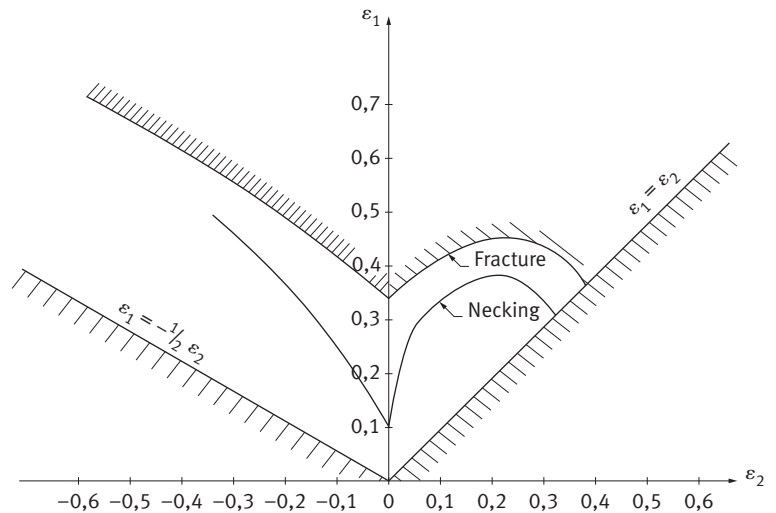

Fig. 2.3.10 - Forming limit curves for X6Cr17 / 1.4016

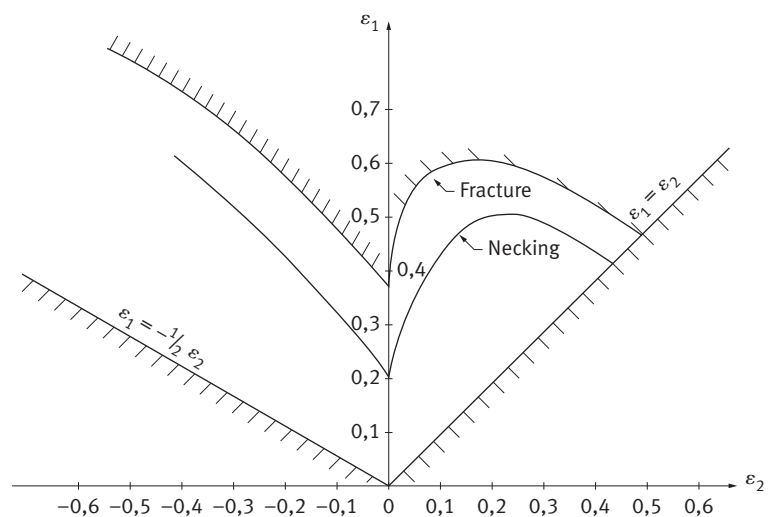

Fig. 2.3.11 - Forming limit curves for X5CrNi18-10 / 1.4301

When plotting forming limit curves, it is assumed that the strain paths are linear, i.e. that the ratio $\varepsilon_2/\varepsilon_1$ remains constant. However, this is not true in practice and recent studies have shown that the actual strain path affects the position of the forming limit curve. Thus, if the initial deformation is in the drawing mode and the final deformation is in biaxial stretching or expansion, necking or fracture will occur at a point well above the forming limit curves determined in the above manner. If deformation begins in the stretching mode and finishes

in the area of drawing, necking and fracture will occur slightly below the conventionally established forming limit curves.

Nevertheless, in practice, the determination of strain contours on real drawn parts, together with a knowledge of the forming limit curves, provides a useful means of analyzing a forming operation. If the measured limiting strain contour is close to the forming limit curve, the risk of failure for a series of parts will be high. If, on the contrary, it is well below the forming limit curve, then the risk will be small.

Modeling

Modeling is the mathematical simulation of a drawing operation by the so-called finite elements technique, in which the blank is divided into a large number of small volume elements represented by a mesh. In modern simulation softwares, the behaviour of each element is determined from the constitutive equations

(flow laws) for the material concerned, taking into account the friction conditions encountered by the blank between the die and the blankholder and beneath the punch. It is also possible to use such models "in reverse", in order to calculate the optimum blank geometry for a given final part shape.

Tooling

The nature of the tooling is of great importance, since it has a decisive influence on the friction conditions and therefore on metal flow during the forming operation. For deep drawing, aluminum bronzes give the best performance. For very high pressures, it is possible to use either a 13% chromium martensitic stainless steel treated to 60 HRC, or an alloy cast iron, whose friction coefficient is intermediate between those of aluminum bronze and steel.

The punch radius should be such as to allow the metal to flow over it without risk of tearing. For ferritic stainless steels, the mini-

mum punch radius is of the order of six times the sheet thickness, whereas for austenitic grades, it is possible to go down to four times the blank thickness. The die radius R is essentially determined by the blank diameter D , the punch diameter d and the sheet thickness t . For the first pass, the relation used is:

$$R = 0.8 [t \times (D - d)]^{1/2}$$

For subsequent passes, the die radius for the pass n is taken as $R_n = (d_{n-1} - d_n)/2$, where d_{n-1} , and d_n are the punch diameters for the passes $n-1$ and n . The clearance between the punch and die must be sufficient

to allow the metal to flow freely. In practice, it is taken equal to twice the blank thickness plus twice its thickness tolerance plus

twice the increase in thickness due to drawing plus twice the thickness of the lubricant film.

Lubrication

Good lubrication of the blank and the tooling is essential for successful drawing. Since stainless steels are generally smoother than other materials subjected to drawing, particular care is necessary to avoid altering the surface appearance and to prevent sticking phenomena detrimental to tool life. Moreover, for parts where an attractive appearance is important, the lubricant must be easy to remove, particularly if it contains corrosive species.

Among the most commonly used lubricants are soluble mineral oils with an addition of about 20% of water, and the so-called

“high pressure” mineral oils, which are well adapted to deep drawing. The latter products may contain chlorinated compounds, and if so, they must imperatively be removed by thorough washing and rinsing in order to avoid corrosion of the drawn parts.

Blanks are often coated with a plastic film between 20 and 100 μm thick before drawing, which both serves as a lubricant and protects the surface. Thick PVC-based coatings enable deep drawing operations in a single pass, while thin polyethylene-based films are used for shallow drawing operations, which are always carried out in a single pass.

Example application

The example described below is only one of many applications involving the drawing of stainless steels, but serves to illustrate the general approach followed. It concerns a flat-bottomed cylindrical part 115 mm in diameter and 260 mm high produced from 1 mm thick X5CrNi18-10 austenitic stainless steel sheet. The transition radius between the bottom and the side wall is 10 mm. It is thus quite clearly a deep drawn component.

The appropriate blank diameter is determined from charts, based on the finished part geometry. In this case the blank diameter is 365 mm. Since the height of the part (260 mm) is more than twice its diameter ($2 \times 115 = 230$ mm), it cannot be produced in a single pass. The reduction ratios, i.e. the

permissible ratios between the punch diameter and the initial or intermediate blank diameter, are given in Table 2.3.4.

With a reduction ratio of 0.55 for the first pass, the diameter of the first intermediate blank will be $365 \times 0.55 = 200$ mm. In order to attain the required final diameter, three more passes will be necessary, with a reduction ratio of the order of 0.8. Thus, in the second pass the diameter can be reduced to

Table 2.3.4 - Reduction ratios between the punch and initial or intermediate blank diameters for different types of stainless steel

European designation according to EN 10088-2		Ratio of punch and blank diameters (first pass)	Ratio of punch and blank diameters (Subsequent passes)
Name	Number		
X6Cr17	1.4016	0.60	0.80
X3CrTi17	1.4510	0.52	0.80
X5CrNi18-10	1.4301	0.55	0.80

$200 \times 0.8 = 160$ mm, while the use of a reduction ratio of 0.85 for the third and fourth passes, gives $160 \times 0.85 = 136$ mm and $136 \times 0.85 = 115$ mm. In this example, the cumulative reduction ratios are 0.55 after the first pass, 0.44 after the second pass, 0.37 after the third pass and 0.31 after the fourth pass.

The increasing amount of cold work from one pass to the next makes the metal gradually stronger, and beyond a hardness of about

35–40 HRC it is impossible to draw it further. This value is attained for a cumulative reduction ratio of about 0.40. In order to restore the initial formability, it is necessary to perform an annealing treatment. If the atmosphere employed is oxidizing, subsequent pickling and passivation will be essential. In the example above, a cumulative reduction of 0.40 is almost attained after the second pass, so that it is at this stage that the annealing treatment must be performed.

Particular behaviour of certain grades during drawing

“Roping” and “ridging”

Unstabilized ferritic stainless steels, also called semi-ferritic stainless steels, are prone to the surface phenomena known as “roping” and “ridging” after certain forming operations, such as contour forming followed by bending, or drawing. The most representative grade in this family is X6Cr17/1.4016. “Ridging” describes the overall profile of the deformed surface and includes both the microgeometry and the “roping” undulations caused by the deformation (e.g. about 15% elongation in a tensile test) (fig. 2.3.12).

The addition of a stabilizing element, such as titanium, modifies the crystallographic texture due to rolling and minimizes roping.

Since the surface microgeometry depends mainly on grain size, the effect of stabilizing additions is only of second order. The titanium stabilized grade X3CrTi17/1.4510 gives quite remarkable results in this respect, and for this reason, its use has become widespread as a replacement for austenitic grades in applications involving deep drawing.

Although they have excellent surface properties and therefore good polishability, niobium-stabilized grades are more subject to ridging. Stabilization with an appropriate combination of titanium and niobium would therefore appear to offer a promising solution for the future.

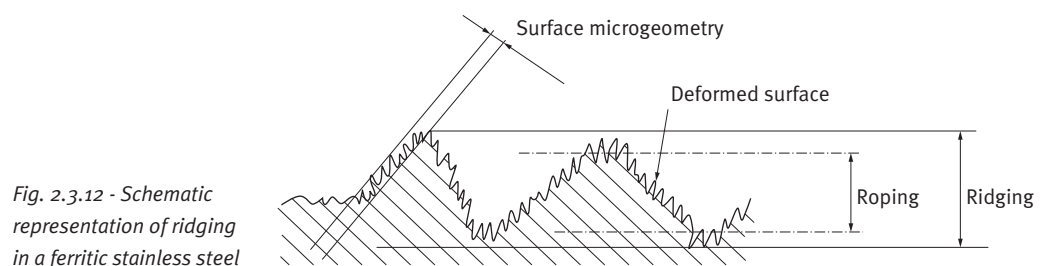

Fig. 2.3.12 - Schematic representation of ridging in a ferritic stainless steel

Delayed cracking

Unstable austenitic stainless steels tend to be subject to the phenomenon of delayed cracking when they are significantly deformed by deep drawing. This is due to the strain-induced transformation of a certain amount of austenite to martensite during the forming operation. Such transformation depends both on the chemical composition of the steel and on the temperature and strain rate during forming. Martensite formation can be beneficial in stretching, since the associated strain hardening limits the tendency for necking. However, in regions of thick components where the deformation mode is of the drawing type, the presence of excessive strain-induced martensite can cause delayed cracking, when the drawing ratio is higher than a critical value for the temperature concerned (fig. 2.3.13). For example, for an unstable 17% Cr–7% Ni austenitic grade deformed at 20 °C, the risk of delayed fracture appears for drawing ratios greater than 1.5.

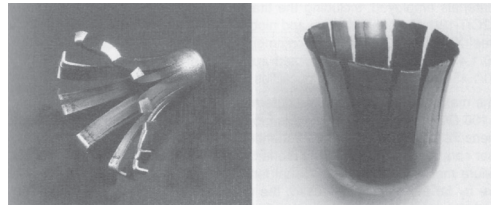

Fig. 2.3.13 - Examples of "delayed cracking" in austenitic stainless steel cups produced in conditions of severe drawing. On the left: flat bottomed cylindrical cup with flange. On the right: flat bottomed cylindrical cup

In order to minimize this risk, the shape of the blank must be carefully optimized with respect to the final part geometry, and the cut-out must be of good quality. Furthermore, the different operations must be performed in close succession, in such a way as to maintain the part at a controlled temperature (warm forming). Finally, the finished part must be trimmed immediately after the final pass. In any doubt, a stress-relieving treatment of at least two hours should be performed at a temperature of about 200 °C.

Tube bending

The bending of stainless steel tubes is an increasingly common operation, particularly due to their extensive use in automobile exhaust systems. All the materials employed, including the titanium stabilized 11% Cr ferritic grade X2CrTi12/1.4512, the titanium and niobium stabilized 17% Cr ferritic stainless steel X2CrTiNb18/1.4509, the common austenitic grades such as X5CrNi18-10/1.4301 and titanium stabilized austenitic grades such as X6CrNiTi18-10/1.4541, possess excellent ductilities particularly favorable for bending.

The maximum elongation in the outermost fiber is given by the formula $e (\%) = 100 D/2R$, where D is the outside tube diameter and R is the bending radius measured at the tube axis. Experience shows that the maximum elongation that can be supported by the tube is 5 to 30% higher than the elongation to failure measured in a conventional tensile test. For thin walled tubes, which are by far the most widely used, the ratio between the diameter D and the thickness t is defined by the inequality $15 < D/t < 40$. In this

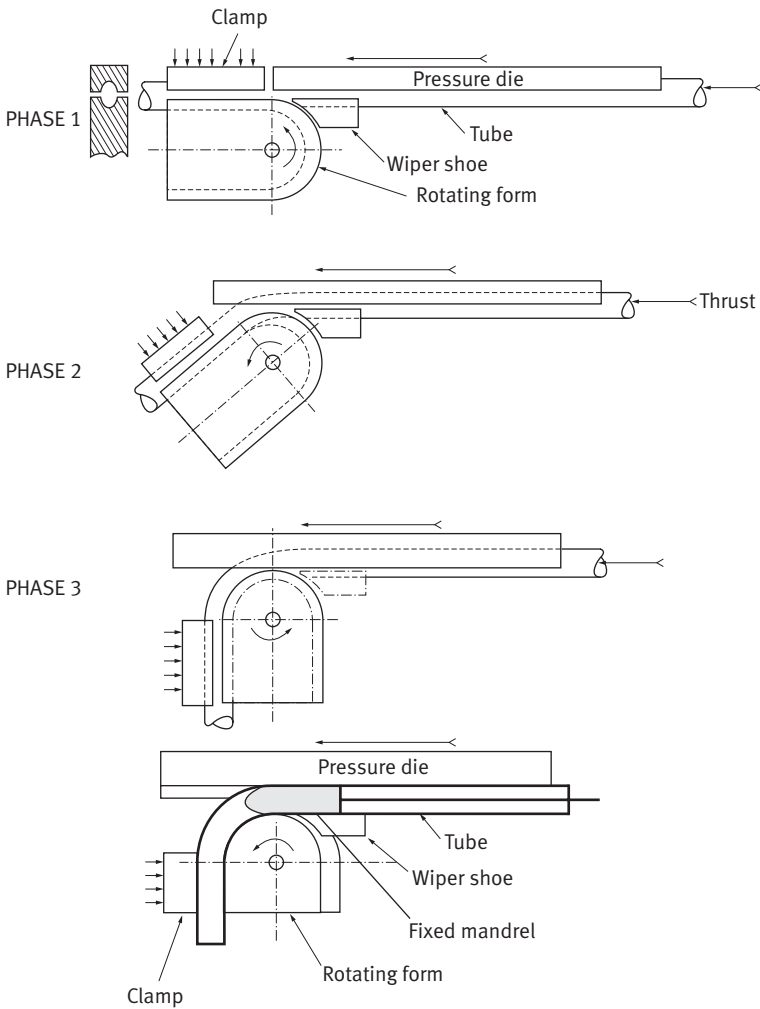
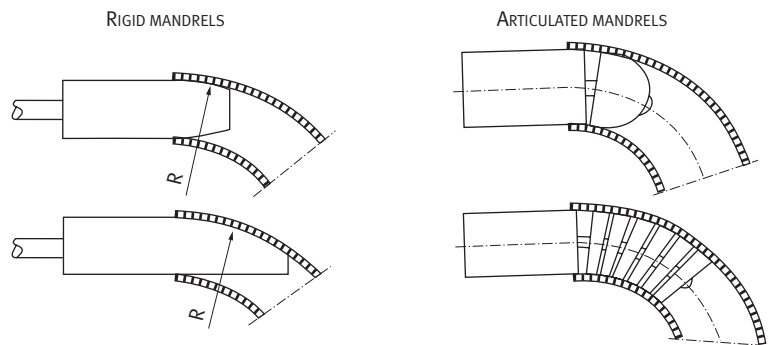

Fig. 2.3.14 - Tube bending machine

geometry range, bending ratios R/D close to 1 can be obtained with modern machines, for both ferritic and austenitic grades. In order to attain this level of performance, it is necessary to use draw bending machines equipped with a mobile pressure die and a wiper shoe, together with a system for exerting a thrust on the tube during bending (fig. 2.3.14).

The fixed internal mandrel (fig. 2.3.15) also plays a vital role. Rigid mandrels are suitable for large bending radii, while articulated mandrels are better adapted for smaller radii. However, in order to use articulated mandrels correctly, the machine must have a powerful mandrel extraction system with a large travel. Finally, lubrication is an important process parameter, and must be sufficient to facilitate sliding of the tube over the mandrel. Because of the high pressure exerted by the tube wall on the mandrel, it is necessary to use "extreme pressure" oils. The oil must be introduced automatically from the mandrel in order to ensure reproducible lubrication.

Fig. 2.3.15 - Tube bending mandrels



Tube hydroforming

Although this technique has been used for more than 30 years for the manufacture of austenitic stainless steel expansion bellows, it has recently gained popularity due to technological improvements in hydroforming machines for tubes. A fluid under a pressure of about 3000 bars can now be injected inside the tube to be formed, a major advantage being that the operation lasts only a few seconds. In this process, the stainless steel is loaded only in the stretching mode, enabling maximum benefit to be drawn from its excellent ductility (fig. 2.3.16). Furthermore, local strain differences are avoided, making it easier to predict the behaviour from forming limit curves. Finally, since the punch used in conventional forming is replaced by a hydraulic fluid, lubrication problems are eliminated.

The first parts produced using the tube hydroforming process were automobile ex-

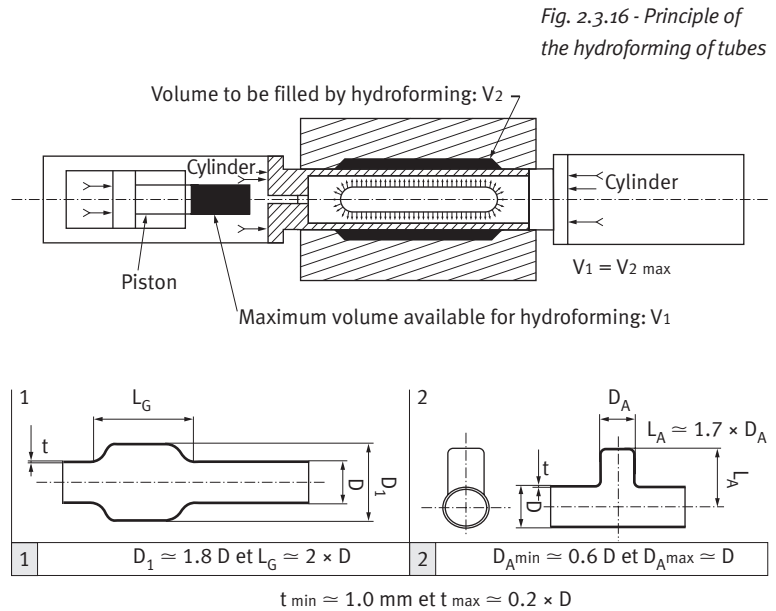

Fig. 2.3.16 - Principle of the hydroforming of tubes

haust system components, particularly manifolds, in X15CrNiSi20-12/1.4828 (fig. 2.3.17) and X6CrNiTi18-10/1.4541 grades. Complex geometry parts in X5CrNi18-10/1.4301 have also been produced from predrawn cylindrical blanks.

Fig. 2.3.17 - Characteristic geometries of hydroformed X15CrNiSi20-12/1.4828 austenitic stainless steel tubes

Lathe spinning

In this process, a tool presses a rotating circular blank over a mandrel of circular symmetry (the mandrel is driven by the lathe and rotates the blank). The tool is supported on a rest and is oriented manually. Forming is performed gradually, in several passes, until the blank is in contact with the mandrel over the whole of its useful area. There is virtually no thinning of the sheet, and spinning can be considered to be essentially a constant thickness forming process (fig. 2.3.18). The force exerted on the tool produces mainly compressive stresses, leading to rapid work hardening. For this reason, lathe spinning

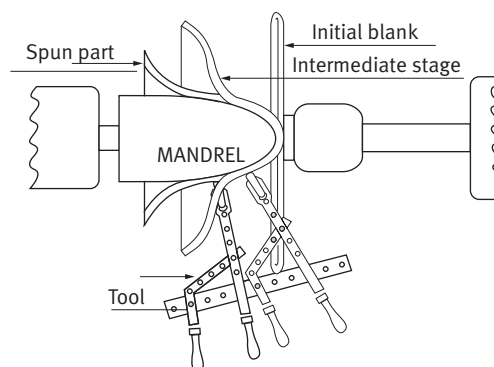

Fig. 2.3.18 - Principle of lathe spinning

is limited to thin gage sheet, generally between 0.3 and 2.0 mm.

The stainless steels best adapted to this process are those with low yield strengths

and which work harden only slowly under the prevailing compressive stresses. In this respect, the standard ferritic alloy X6Cr17/1.4016, and especially the titanium and/or niobium stabilized grades (e.g. X3CrTi17/1.4510, X2CrTiNb18/1.4509), are particularly appropriate, due to their low strain hardening rates. For stable austenitic stainless steels little prone to the formation of strain-induced martensite, the peripheral forming speeds depend on the blank diameter. For small blanks, with diameters of the order of 200 mm, they are about 600 m/min, but must be reduced to around 300 m/min for larger sizes, of the order of 800 mm.

Flowturning

Flowturning is basically quite similar to spinning, and indeed, is often referred to as “power spinning” or “shear spinning” or “compression spinning”. However, a major difference is that the sheet thickness is deliberately reduced, so that it is in fact a stretching operation. The tool is a rotating roller which is displaced perpendicular to the mandrel surface, against which it squeezes the blank. The tool rest is hydraulically or mechanically powered. The inside shape of the finished part corresponds rigorously to the geometry of the mandrel (fig. 2.3.19). The shapes most commonly produced using this technique are cones, with apex angles between 10° and about 60° . Compared to lathe spinning, the wall thickness is better controlled. Depending on the component geometry and the type of stainless steel (ferritic or austenitic), reductions in thickness of up to 60% are commonly attained.

Lubrication is important in this process, in order to prevent the tool from sticking to the workpiece, which can cause surface defects. Because of the pressures involved, “high pressure” mineral oils must be used.

While lathe spinning requires a relatively small capital investment compared to drawing, the productivity is fairly low. The process is therefore used essentially for prototyping and small series manufacture. However, the deformation mechanisms involved in spinning are different from those in drawing, so that if the technique is used to make prototypes, a completely new study must be made before series manufacture by deep drawing.

A variant of this process, which can be called cylindrical flowturning, is used to produce hollow components with very large height/diameter ratios, starting from a drawn flat-bottomed cylindrical blank. Depending on the type of stainless steel and the nature of the forming roller, the tool translation speed in this case varies between 200 and 800 mm/min.

Fig. 2.3.19 - Principle of flowturning

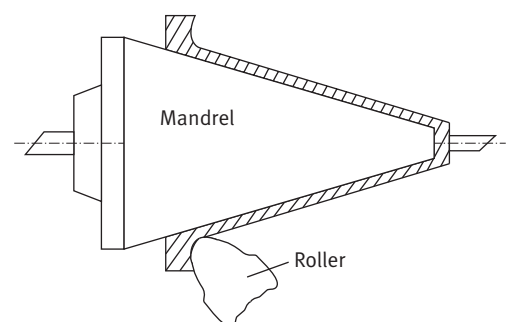

2.4 Hot forming

Whenever possible, it is preferable to use cold forming processes, since hot forming inevitably causes surface oxidation of the stainless steel, decreasing its wet corrosion resistance. When hot forming cannot be avoided, it is necessary to reform the passive layer by a subsequent pickling and passivation treatment.

Hot forming of austenitic stainless steels

Hot forming is essentially used for heavy gage sheet. It must be carried out in the temperature range between 950 and 1300 °C, and it is essential to avoid prolonged residence between 500 and 900 °C during either heating or cooling. If the cooling is sufficiently rapid, additional annealing is not necessary. If this is not the case, annealing must be performed at 1100 °C, followed by rapid cooling to ambient temperature.

Hot forming of ferritic stainless steels

In this case, hot forming is carried out between 850 and 1100 °C. In non-stabilized grades, there is a high risk of sensitization due to the precipitation of chromium carbides at grain boundaries during subsequent cooling, leading to a marked loss in corrosion



Photo 7: The glass-steel structure “La lentille de la cour de Rome” (The lens of the Rome yard) – Paris (F)

resistance. In order to prevent this risk, it is essential to perform a post-forming annealing treatment between 750 and 850 °C, followed by rapid water or air cooling.

Hot forming of austenitic-ferritic duplex stainless steels

Hot forming must imperatively be performed above 950 °C. If the temperature is maintained above this value throughout the forming operation and if the subsequent cooling is rapid, further annealing is not

necessary. If this is not the case, treatment at 1100-1150 °C followed by rapid cooling is essential.

Photo 8: Hot extruded sections, used for the glass-steel structure “La lentille de la cour de Rome” (The lens of the Rome yard) – Paris (F)



Hot tube bending

The vast majority of tube bending operations are carried out at ambient temperature. However, in certain rare cases, it may be necessary to bend tubes in situations where a

Austenitic stainless steel tubes

As indicated in the section “hot forming of austenitic stainless steels”, bending must be performed between 950 and 1300 °C. If the heating and cooling are sufficiently rapid, the risk of chromium carbide precipitation between 500 and 900 °C is practically negligible.

Ferritic stainless steel tubes

Bending should be performed between 850 and 1100 °C, according to the recommendations given in the section “Hot forming of

Finishing operations

Once the tube has been bent and cooled down to ambient temperature, the two ends are cut and the sand is removed. It is then necessary to pickle and passivate both the inside and outside. If the tube is intended to trans-

bending machine is not available. Bending can then be satisfactorily performed at high temperature by the following procedure. First of all, one of the tube ends is hermetically closed by welding on a full flange. The tube is then placed in the vertical position and filled with perfectly dry sand, with a grain size of about 100 µm (or 150 mesh) to ensure good flowability and complete filling, carefully compacting it as filling proceeds. When the tube is full, the top end is sealed by welding on another full flange. When prepared in this way, the tube can be heated and bent to the required radius on a suitable form.

In these conditions, subsequent annealing and quenching are not necessary. Since heating is generally performed with a torch, care must be taken that the flame is neither reducing nor carburizing, but slightly oxidizing.

ferritic stainless steels”. As for austenitic grades, the torch used for heating should be slightly oxidizing.

port a fluid, chemical treatment of the inside is absolutely essential. If it is to serve a decorative purpose, the external surface should be polished with an abrasive of appropriate grain size after chemical pickling.

3. Joining operations

3.1 Welding

The microstructure of stainless steel welds in the as-welded condition, i.e. without any further heat treatment, is mainly determined by the concentrations of different alloying elements. The latter can be divided into two groups of opposite influence:

- Austenite stabilizers, which act like nickel, including carbon, manganese, cobalt, copper, etc.
- Ferrite stabilizers, which act like chromium, such as molybdenum, silicon, niobium, titanium, aluminum, etc.

The combined effects of the various elements can be evaluated in terms of a chromium equivalent and a nickel equivalent, and are represented graphically in diagrams with these two parameters as the orthogonal axes, in which the different as-welded microstructures are represented as “phase fields”. The best known diagram is that due to Schaeffler (1949), but improved versions also exist, such as the De Long (1973) and Welding Research Council – WRC (1992) diagrams. It is found that:

- Fully austenitic weld structures, generally associated with high nickel contents, are sensitive to the solidification cracking or “hot cracking” phenomenon, which occurs during cooling, at temperatures above about 1250 °C.
- Completely ferritic weld structures are strongly prone to grain coarsening at high temperatures, above about 1150 °C, which can cause loss of ductility and toughness, leading to low temperature brittleness.
- Entirely martensitic structures are susceptible to cold or hydrogen-assisted cracking, which originates during cooling at temperatures below 400 °C and is generally of a delayed nature, occurring from a few hours to several days after the welding operation.

The microstructural modifications that occur in the different types of stainless steel during welding, together with the recommended precautions, are given in Table 3.1.1.



Photo 9: Manual Gas Tungsten Arc Welding

Type of stainless steel	Principal characteristics of the as-welded joint and recommended precautions
Martensitic 10,5–13% Cr 0.2–0.5% C	<ul style="list-style-type: none"> • Sensitive to cold cracking, depending on the carbon and hydrogen contents and residual stress levels, below about 400 °C, whence the following recommendations: <ul style="list-style-type: none"> – Preheating to 200–300 °C is generally necessary; – Use of low hydrogen welding products; – Post heating to about 300 °C. • High tensile strength and hardness. • Good toughness, particularly for low carbon grades.
Semi-ferritic 17% Cr 0.04% C	<ul style="list-style-type: none"> • Sensitive to embrittlement by grain coarsening above 1150 °C (preheating to be proscribed). • Poor toughness and ductility. • Sensitive to intergranular corrosion, particularly in the heat affected zone, (HAZ). • Post-weld heat treatment at about 800 °C restores the mechanical properties and intergranular corrosion resistance.
Ferritic 17–30% Cr 0.02% C Stabilized with: Ti, Nb	<ul style="list-style-type: none"> • Sensitive to embrittlement by grain coarsening above 1150 °C (preheating to be proscribed). • Sensitive to the so-called « 475°C embrittlement » (temperature range : 350–550°C) which can be reversed by annealing • Satisfactory ductility and improved toughness compared to semi-ferritic grades. • Generally insensitive to intergranular corrosion.
Austenitic 18% Cr–8% Ni 0.05% C	<ul style="list-style-type: none"> – <i>Fully austenitic structures:</i> <ul style="list-style-type: none"> • Sensitive to hot cracking during solidification. • Good resistance to intergranular corrosion for stabilized and low carbon grades. • Excellent toughness and ductility. – <i>Structures containing a few percent of ferrite:</i> <ul style="list-style-type: none"> • Insensitive to hot cracking. • Good resistance to intergranular corrosion for stabilized and low carbon grades. • Embrittlement by decomposition of the ferrite to form sigma phase for long exposures between 550 °C and 900 °C, such as can occur in heavy gage products. The relative effects of temperature and time are illustrated by the fact that 1000 hours at 650 °C is roughly equivalent to 10 hours at 750 °C. • Excellent toughness and ductility.
Austenitic-ferritic Duplex 22% Cr–5% Ni 3% Mo–0.02% C	<ul style="list-style-type: none"> – <i>Two-phase austenite + ferrite structures:</i> <ul style="list-style-type: none"> • Insensitive to hot cracking. • Excellent toughness and good ductility in the temperature range -40 °C to +275 °C. • Sensitive to embrittlement by sigma phase when exposed between 500 °C and 900 °C.

Table 3.1.1 - Weld characteristics and recommended precautions for different types of stainless steel

Welding processes

There are a large number of welding processes that can be applied to stainless steels, but only a few of them are really appropriate for these materials, and are summarized in Table 3.1.2.

Electric arc processes	Resistance and induction processes	Radiation energy processes
<ul style="list-style-type: none"> • With a refractory metal electrode: <ul style="list-style-type: none"> – GTAW or TIG or WIG – PAW (plasma) • With a fusible electrode: <ul style="list-style-type: none"> – GMAW or MIG – SMAW (covered electrode) – SAW (Submerged metal arc) – FCAW (flux-cored arc) 	<ul style="list-style-type: none"> • Pure resistance heating: <ul style="list-style-type: none"> – spot welding – seam welding – projection welding • Flash butt welding • High frequency HF or medium frequency MF induction welding (longitudinal welding of tubes) 	<ul style="list-style-type: none"> • Laser beam welding • Electron beam welding

Table 3.1.2 - The principal welding processes used for joining stainless steels

Arc welding

Gas Tungsten Arc Welding (GTAW)

The GTAW (Gas Tungsten Arc Welding) process, also known as the TIG (Tungsten Inert Gas) or WIG (Wolfram Inert Gas) process, is illustrated in figure 3.1.1. The energy necessary to melt the metal is supplied by an electric arc struck and maintained between a tungsten or tungsten alloy electrode and the workpiece, under an inert or slightly

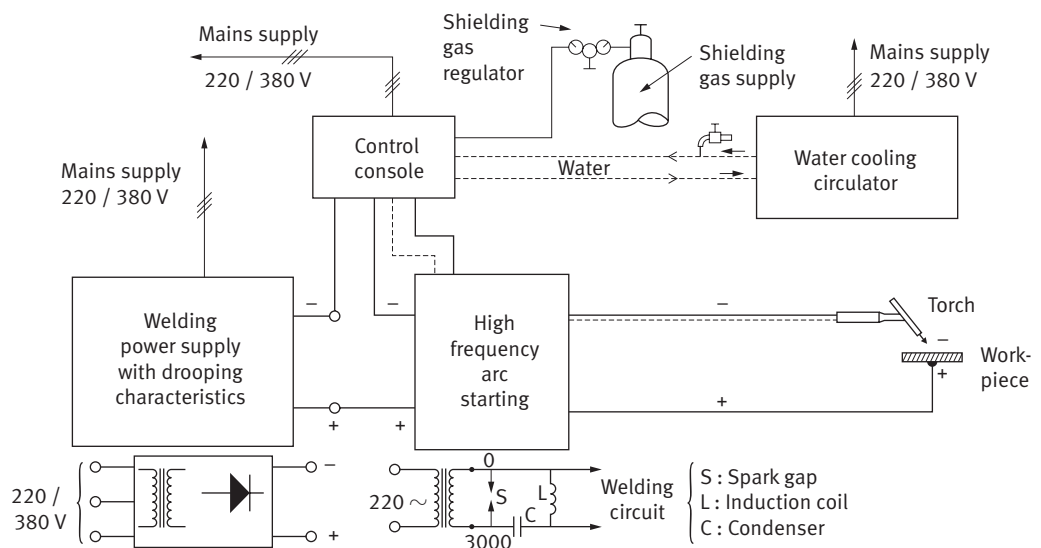

Fig. 3.1.1 - Principle of a GTAW or TIG manual welding apparatus

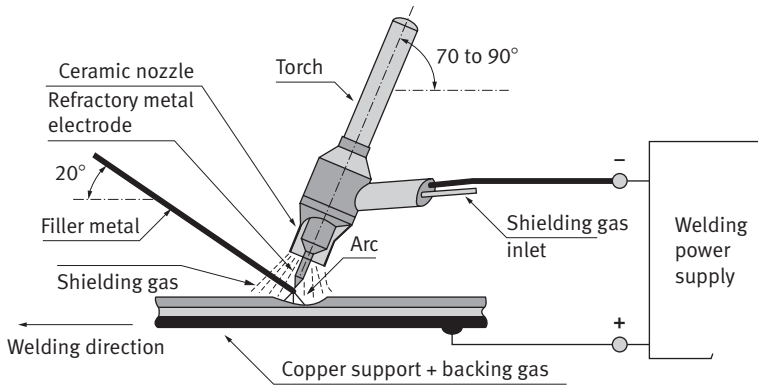

Fig. 3.1.2 - Example of manual welding using the GTAW (TIG) process

reducing atmosphere. Stainless steels are always welded in the DCEN (direct current electrode negative) or straight polarity DC mode, the negative pole of the generator being connected to the electrode. In these conditions, it is the workpiece that is struck by the electrons, enhancing penetration, while the electrode, which is generally made from thoriated tungsten (2% ThO₂), undergoes very little wear. Welding is performed either manually or automatically. If a filler metal is employed, it is in the form of either bare rods (fig. 3.1.2) or coiled wire for automatic welding (fig. 3.1.3). The inert gas flow which protects the arc zone from the ambient air enables a very stable arc to be maintained.

The advantages of this process for welding stainless steels can be summarized as follows:

- a concentrated heat source, leading to a narrow fusion zone;
- a very stable arc and calm melt pool of small size;
- good quality, sound and pore-free welds;
- very low electrode wear;
- rapid apprenticeship.

The active component of the torch is its refractory electrode, generally made from

thoriated tungsten (1–3% ThO₂), which facilitates initiation of the arc and decreases the risk of contamination. In the recommended DCEN mode, the electrode diameter must be chosen as a function of the welding current as indicated in Table 3.1.3.

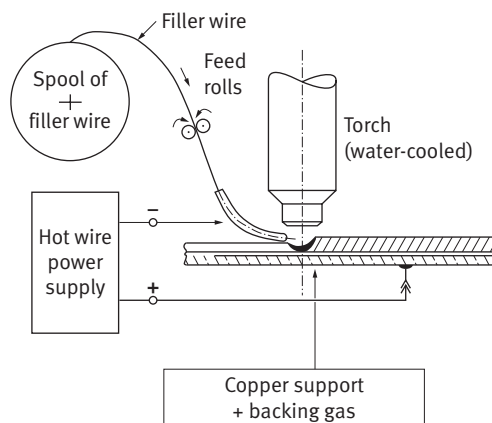

Fig. 3.1.3 - Example of automatic welding using the GTAW process. The filler metal can be used either cold or hot. In the latter case, it is resistance heated via an auxiliary current source

DCEN welding current (A)	Electrode diameter (mm)
25 – 70	1.0
60 – 150	1.6
100 – 200	2.0
200 – 350	3.0
350 – 500	4.0
500 – 800	5.0

Table 3.1.3 - Refractory electrode diameter as a function of welding current

The shielding gases are defined by the EN 439 standard. Pure argon is generally used in manual welding, although argon-helium or argon-hydrogen mixtures can be employed in certain difficult cases. However, argon-oxygen mixtures are to be proscribed, since they lead to rapid deterioration of the refractory electrode. Argon-helium mixtures are used when a compromise is sought between the arc stability and facility of initiation characteristic of argon and the good penetration, high welding speeds and sound structures promoted by helium. Mixtures of this type can be used for austenitic, ferritic and martensitic stainless steels. Argon-hydrogen mixtures (R1 or R2) are widely used for welding austenitic stainless steels, for both automatic and manual welding. The 95% Ar–5% H₂ mixture is often employed for automatic welding, since it improves penetration, decreases the width of the weld seam, and significantly increases the welding speed (by up to 50% compared to pure argon). With argon-hydrogen mixtures, the risk of undercut formation is less than for argon-helium mixtures. However, argon-hydrogen mixtures must not be used for welding ferritic, martensitic or duplex stainless steels, due to the risk of hydrogen embrittlement in the weld joint. For the welding of duplex stainless steels without filler metal, argon-nitrogen mixtures are often used in order to maintain a correct balance of austenite and ferrite in the weld, since nitrogen is a powerful austenite stabilizer.

For the backing gas, which protects the rear of the workpiece, argon is most commonly employed, although nitrogen is sometimes used for duplex grades, or for austenitic alloys where it is sought to reduce the amount of ferrite at the weld root. However,

like hydrogen, nitrogen is to be proscribed for ferritic and martensitic stainless steels.

In welding applications, the term “stainless steels” is often implicitly reduced to austenitic stainless steels. It must not be forgotten that the ferritic, duplex, and even martensitic grades, can also be welded, albeit with significantly different operating procedures. In particular, welds of remarkable quality can be obtained with the titanium and/or niobium stabilized ferritic stainless steels, provided that certain elementary precautions are taken concerning hydrogen and nitrogen.

When a filler metal is necessary, it is in the form of either a bare rod for manual welding, or a coiled wire for automatic processes.

The TIG process can be readily automated due to the very low electrode wear and the highly stable arc. The main problem in automation is to maintain the arc length constant as it is displaced longitudinally along the joint. In all cases, it is essential to carefully prepare the edges to be joined and to ensure a regular feed of filler wire.

For sheet thicknesses between 1.5 and 15 mm, it is frequent in manual welding to operate in the vertical up butt mode (fig. 3.1.4). In this case, the molten pool is well protected from the external atmosphere, since the two sides of the joint are in contact with the shielding gas.

It is also common practice to use the TIG process for spot welding (fig. 3.1.5). The weld spot is obtained by striking the arc at the corresponding position and then maintaining it for the required length of time. The torch is equipped with a special nozzle which allows the gas to escape. The top sheet must be sufficiently thin to be

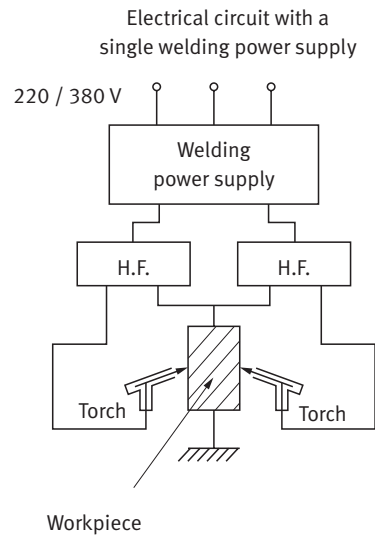
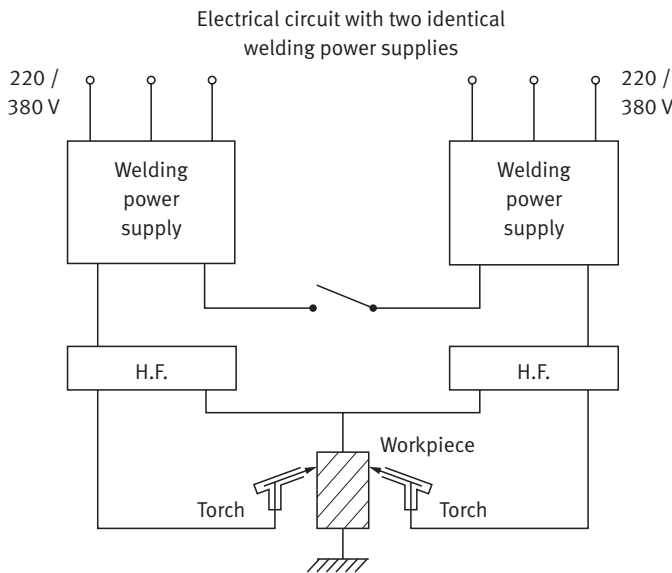

Fig. 3.1.4 - Principle of simultaneous two-operator TIG welding – Two operators weld in one pool on both sides at the same time

readily penetrated, generally between 0.5 and 1.5 mm. The shielding gases that can be used in this case are pure argon, and argon-helium mixtures when deeper penetration is required. Argon-hydrogen mixtures can also be employed, but must be strictly reserved for austenitic grades.

Activating flux TIG (A-TIG) or flux-assisted GTA welding is a new method in which Gas Tungsten Arc Welding (GTAW) is conducted by covering a thin layer of an activating flux on the weld preparation before starting the welding operation.

The aim of this method is to increase the performance and productivity of the GTA process. The main improvement lies in that the penetration can be increased up to three times. This technology was first established in the 1960s by the E.O. Paton Electric Welding Institute of Ukraine.

The action of activating flux is based on its influence on the surface gradient $d\gamma$, which takes place in the weld pool. Normally, surface tension gradients decrease with increasing of

Fig. 3.1.5 - Principle of spot welding using the TIG process

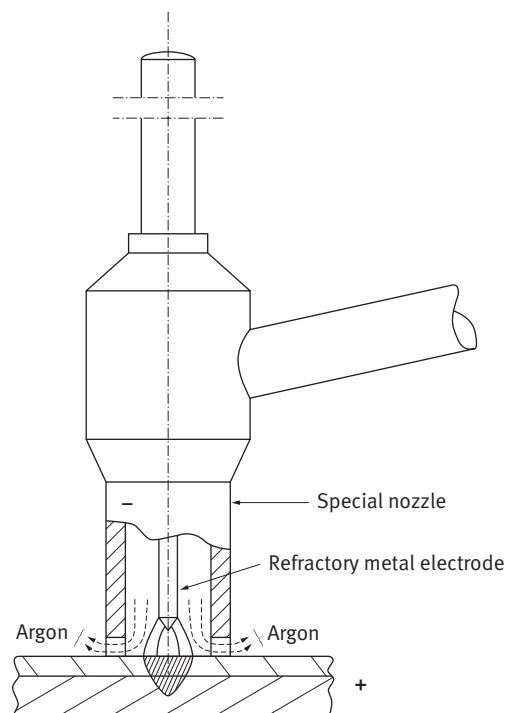

temperature (T) in many alloys, i.e. $d\gamma/dT < 0$, and molten metal flows from the region with low surface tension to that with high surface tension ($\gamma_2 > \gamma_1$).

The temperature T_1 being higher at the center of the weld pool, the surface tension γ_1 at the center is lower than γ_2 in the outer zone. Therefore, molten metal flows as shown in figure 3.1.6 given a relatively wide shallow weld.

However, a surface-active element such as sulphur (S) can change the direction of

the molten metal in weld pool. With a sufficient content in sulphur (of the order of 0.007%), $d\gamma/dT > 0$ and the molten metal flows as shown in figure 3.1.7, giving a relatively deep and narrow weld.

If there is a surface tension gradient in the weld pool (Marangoni effect) as it is shown in figure 10.7, the convection currents are directed towards the interior of the weld pool promoting a good penetration. If not, penetration can be improved by a factor of up to three using activating flux.

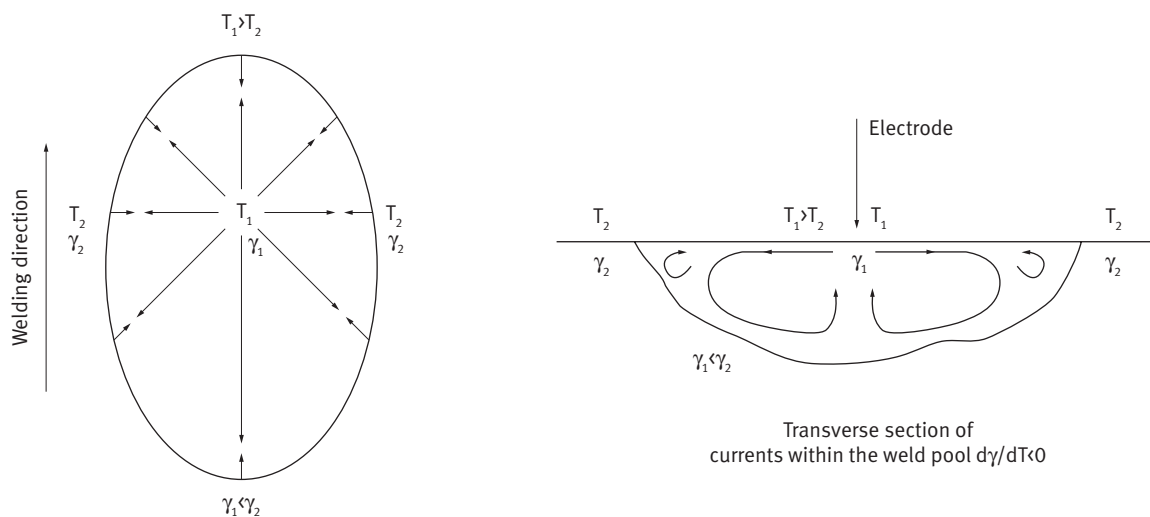

Fig. 3.1.6 – Fluid flow on and below the weld pool surface – negative surface tension temperature coefficient

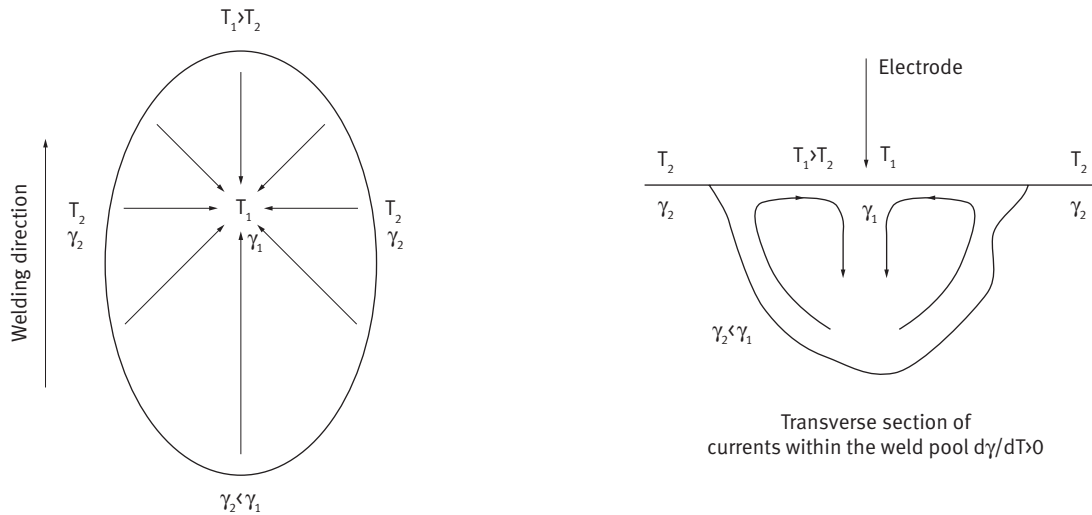

Fig. 3.1.7 – Fluid flow on and below the weld pool surface – positive surface tension temperature coefficient

Activating fluxes are normally easy to handle. They can be used for autogenous GTA welding on thin materials for the purpose of minimizing the effects of heat-to-heat variations and mainly on thick materials up to the order of 5 mm – using a square butt penetration – to achieve full penetration in a single pass. The activating flux is applied – figure 3.1.8 – to the weld preparation as a slurry using a brush, dries in very short time, and is ready to be welded using conventional GTA

welding. For multiple pass welding it is recommended to remove previously fused flux from the weld using a stainless steel brush.

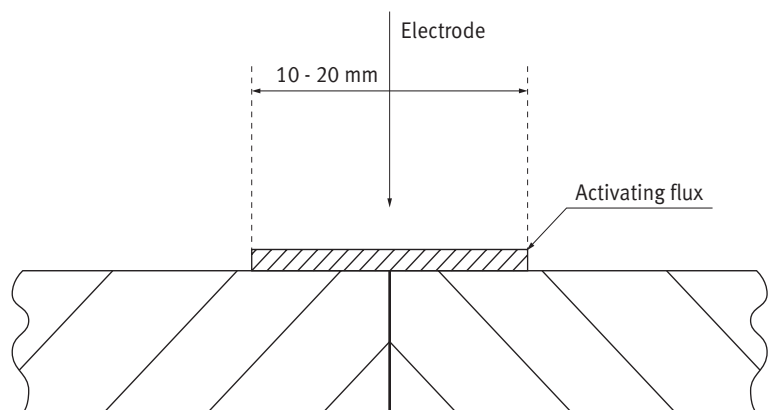
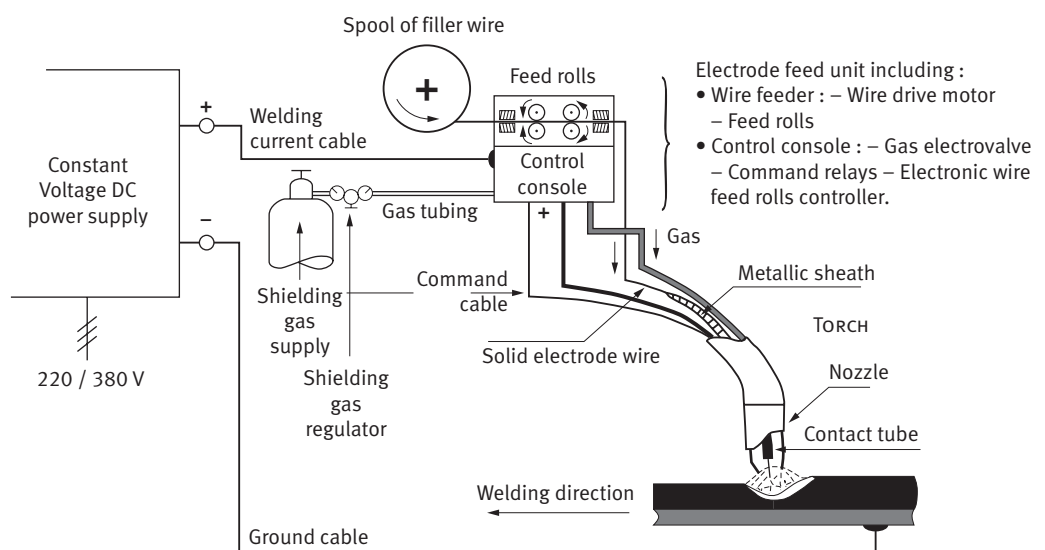

Fig. 3.1.8 – Joint cross section

Gas Metal Arc Welding (GMAW)

The GMAW (Gas Metal Arc Welding) process, also known as the MIG (Metal Inert Gas) process, is illustrated in figure 3.1.9. Contrary to the GTAW process, the electrode

is consumable, an arc being struck between the fusible filler wire and the workpiece under a shielding gas. The essential characteristics of this process are:



- the use of very high current densities in the electrode wire ($> 90 \text{ A/mm}^2$), about 10 times higher than in the covered electrode (SMAW) process;
- rapid melting of the electrode wire (about 8 m/min) due to the high temperature of the arc, making it necessary to use an automatic wire feed system, supplied by 12 kg spools;
- stainless steels are always welded in the DCEP (direct current electrode positive) or reverse polarity DC mode, the positive pole of the generator being connected to the electrode;
- the welding torch is generally held manually (so-called “semi-automatic” process),

but for high welding powers it is fixed to a carriage (“automatic” process). The mechanism of metal transfer in the arc is an important process parameter, three principal modes being distinguished (fig. 3.1.10):

- The short-circuiting or dip transfer mode, in which the metal melts to form large droplets, whose diameter is often greater than that of the electrode wire. As the droplet forms at the end of the electrode, it makes contact with the melt pool and creates a short circuit, with a sudden increase in current. The surface tension causes a pinching effect which separates the droplet from the electrode. The frequency of this phenomenon is of the

order of 20 to 100 Hz, corresponding to cycle times between 0.01 and 0.05 seconds.

- The globular or gravity transfer mode. As in the previous case, melting occurs in the form of large droplets, which break away when their mass is sufficient to overcome surface tension forces, and due to the greater arc length, fall freely before coming into contact with the melt pool.
- The spray transfer mode involves current densities above a certain transition level, of the order of 200 A/mm^2 . The electrode melts to give a stream of fine droplets. As the current density increases further, the end of the electrode becomes conical and the stream of even finer droplets is released axially.

The shielding gases are defined by the EN 439 standard. They must be either neutral, slightly reducing, or very slightly oxidizing. The principal mixtures employed are as follows:

Argon-oxygen mixtures (M13)

Very small concentrations of oxygen are sufficient to significantly reduce the surface tension of the liquid metal and increase the stability of the arc. The weld bead then shows better wetting behaviour and the risk of undercut formation diminishes. However, the effect of oxygen is most marked in the spray transfer mode. In practice, the oxygen content is limited to 2% whatever the grade of stainless steel.

Argon-CO₂ mixtures (M12)

The effects of CO₂ on transfer are similar to those of oxygen, but since the corresponding

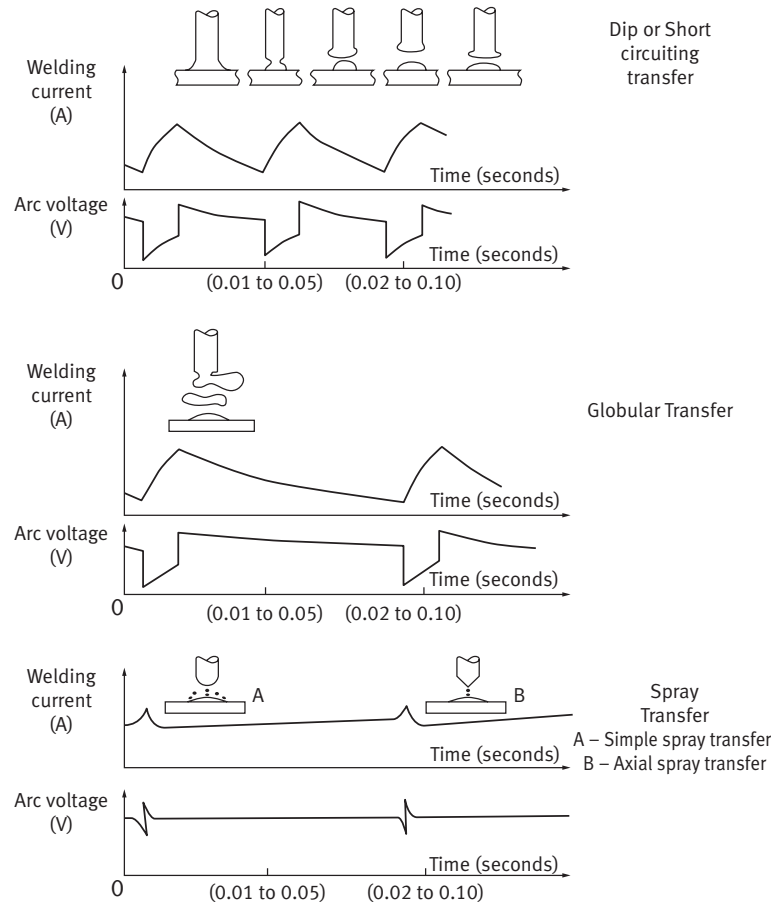

Fig. 3.1.10 - Metal transfer modes in MIG welding

oxygen potential is much lower, oxidation of the weld bead is significantly reduced. In practice, the CO₂ content is limited to 3%, which is the maximum permissible value for ferritic stainless steels.

Argon-CO₂-H₂ mixtures (M11)

These mixtures are widely used, the typical composition being 95–96% Ar, 3% CO₂, 1–2% H₂. They give excellent arc stability in

the short-circuit transfer mode and the CO₂ does not cause appreciable carbon pick-up. However, the hydrogen content is sufficiently high for these mixtures not to be recommended for ferritic stainless steels when no post-weld heat treatment is to be performed.

*Argon-helium-oxygen
and argon-helium-CO₂ mixtures*

These mixtures can be considered as a logical extension of the argon-oxygen and argon-CO₂ mixtures. They are observed to enhance the fluidity of the melt pool, to improve the bead profile and to produce a more sound, compact weld. When the oxygen and CO₂ levels remain less than 2 and 3% respectively, they can be used for welding ferritic stainless steels.

*Argon-oxygen-nitrogen
and argon-CO₂-nitrogen mixtures*

For welding nitrogen-containing austenitic stainless steels and duplex grades, nitrogen can be added to the shielding gas to minimize losses from the molten metal. In the case of duplex alloys, nitrogen plays an important role in obtaining the correct balance between austenite and ferrite in the weld structure.

The welding parameters recommended for the MIG welding of austenitic stainless steels with solid electrode wire and argon-oxygen or argon-CO₂ shielding gas are indicated in Table 3.1.4.

As for TIG welding, there is a MIG spot welding process, using a torch equipped with a special nozzle (fig. 3.1.11) and a control unit with a timing device, enabling adjustment of the duration of the arc maintenance period (from 0.5 to 5 seconds).

Fig. 3.1.11 - Spot welding using the GMAW process

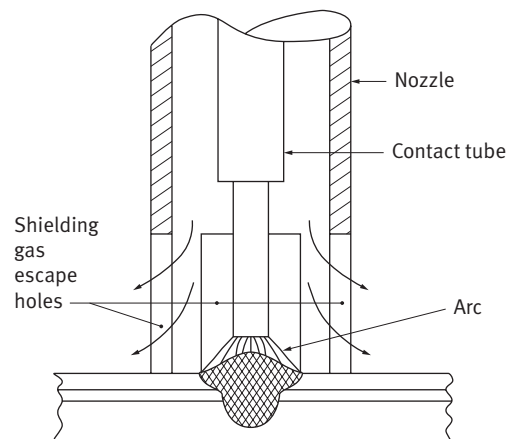

Table 3.1.4 - Recommended MIG welding parameters for austenitic stainless steels

Solid wire diameter (mm)	Welding current (A)		Arc voltage (V)		Ar-O ₂ or Ar-CO ₂ flowrate (l/min.)
	Short-circuit transfer	Spray transfer	Short-circuit transfer	Spray transfer	
0.8	60 – 80	140 – 210	15 – 17	25 – 28	15
1.0	80 – 120	180 – 250	16 – 18	26 – 29	20
1.2	120 – 150	220 – 290	17 – 20	27 – 30	25

For pulsed GMAW, several types of power sources are available: inverter and transistor power supplies, constant-voltage, that offer independent setting of pulse parameters. More sophisticated power supplies employ synergic controls preprogrammed for a range of wire-feed speeds which provide the optimum combination of the background current and pulse peak current especially useful in the vertical up and overhead positions.

The latest improvement is the “Surface Tension Transfer” (STT) process in which the possibility of adjusting background and peak currents, makes the arc very stable. The current is adjusted in a couple of microseconds, resulting in a tremendous decrease of spatter level (friendly process) and a decrease of fume formation rate (safe process). One of the main applications is in root runs of pipes and more generally vertical up butt welds, overhead welds, and tubular connections.

A variant of MIG welding is the FCAW (Flux Cored Arc Welding) process, in which the electrode wire is composed of a stainless steel sheath filled with a solid flux (fig. 3.1.12), whose role is similar to that of the electrode covering in the manual SMAW (Shielded Metal Arc Welding) process. The principal interest of the FCAW technique is that it combines the advantages of the SMAW method with the high productivity of an automatic or semi-automatic process, due to the possibility of continuously feeding the cored wire. Compared to a conventional solid electrode, the flux both provides a slag cover and enhances productivity. Thus, for a current of about 200 amps, the deposition rate is about 100 g/min for a solid 1.6 mm

diameter wire containing 20% Cr and 10% Ni, compared to about 170 g/min for a flux-cored wire of the same diameter. This large difference is due to the fact that in the flux-cored wire, only the metal sheath conducts electricity, since the core, composed of a mixture of mineral and metal powders, possibly bound in an alkaline silicate, has a high electrical resistivity.

If A is the cross-sectional area of the sheath, L the stick-out of wire between the contact tube and the workpiece, and I the welding current, then the deposition rate M , in g/min, is given by the relation:

$$M = K_1 + K_2 \cdot I + K_3 \cdot L \cdot I^2 / A$$

where K_1 , K_2 and K_3 are proportionality coefficients.

Note: Confusion often arises between the MIG (Metal Inert Gas) and MAG (Metal Active Gas) welding processes. In fact, in the MIG process, the oxidizing nature of the shielding gas is negligible, whereas it is deliberately enhanced in the MAG process. It is for this reason that only the MIG technique is used for stainless steels, whereas MAG welding is well adapted for plain carbon steels.

However, in the GMAW/MIG process, a low percentage of oxygen (O_2) or carbon dioxide (CO_2) is often needed in the shielding gas (argon – Ar) to improve both arc stability and wetting by the molten metal. Typical levels are 2% O_2 or 3% CO_2 . Higher levels of O_2 or CO_2 give excessive oxidation of chromium (Cr), manganese (Mn) and silicon (Si) and excessive pick-up of carbon (C) in the weld pool. For example, the carbon content (% C) in the weld metal, which is 0.025% for 2% CO_2 containing shielding gas, could reach 0.04% for 4% CO_2 .

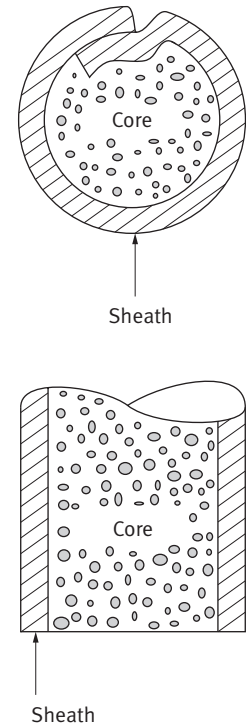

Fig. 3.1.12 - Example of a flux-cored electrode wire

Plasma Arc Welding (PAW)

The principle of plasma arc welding is illustrated in figure 3.1.13. The constriction of an electric arc was first attempted in the 1920's by Gerdien and Lotz, whose experimental device confined an arc between two graphite electrodes in the presence of water vapor. However, the concept was not applied to welding until 1955, when the American company Union Carbide filed a patent for a constricted arc system derived from the TIG process. Constriction of the arc produces a stream of ionized gas, called plasma, which is a perfect electrical conductor. The energy available is highly concentrated, and temperatures between 10000 and 20000 K are attained. Welding processes generally employ a "transferred arc" configuration, where the constricted arc is formed between the electrode and the workpiece, whereas other applications more often use a "non-transferred" constricted arc, which is established between the electrode and

a special orifice. Since the plasma jet is extremely narrow, it cannot provide adequate protection for the melt pool, so that it is necessary to add a larger diameter annular stream of shielding gas.

The gases used both for this purpose and for forming the plasma are similar to those employed in TIG welding, namely pure argon, Ar-5% H₂, Ar-10% H₂ and 25% argon-75% helium. The hydrogen-containing mixtures are recommended for welding austenitic stainless steels, but like in the case of TIG welding, are to be proscribed for ferritic, martensitic and duplex grades. For the latter materials, it is recommended to add nitrogen to maintain the appropriate proportions of austenite and ferrite in the weld.

In manual plasma welding, where the torch is hand-held, the so-called "microplasma" and "mini-plasma" processes are employed for currents between 0.1 and

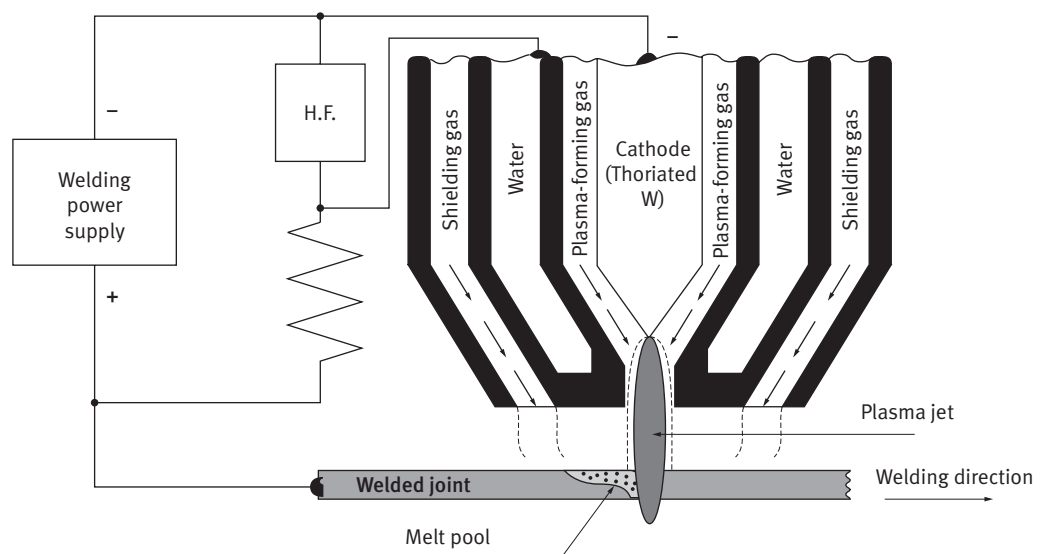

Fig. 3.1.13 - Principle of keyhole plasma welding (the jet penetrates the workpiece and emerges from the other side)

15 amps, and the “non-emergent jet” technique for currents between about 15 and 100 amps. In automatic welding, where the torch is mounted on a carriage, the so-called “keyhole” process is employed. Compared to TIG welding, it is important to emphasize that the shape of the nozzle and the position of the electrode with respect to the nozzle orifice play an essential role in constriction of the arc. The major advantage of the PAW process over TIG welding is the remarkable stability of the arc, leading to:

- a “rigid” arc which enables better control of power input;
- greater tolerance to variations in nozzle-workpiece distance, without significant modification to the weldment morphology;

- improved welding with filler metal, due to the greater distance between the nozzle orifice and the workpiece;
- a narrower heat-affected zone (HAZ) and generally faster welding speeds;
- greater tolerance to faulty preparation, particularly in the case of keyhole welding.

Table 10.5 indicates the welding parameters recommended for type X₅CrNi18-10/ 1.4301 grade austenitic stainless steel.

Table 3.1.5 - Recommended keyhole welding parameters for type X₅CrNi18-10/1.4301 austenitic stainless steel, for butt welds

Sheet thickness (mm)	Welding current (A)	Plasma gas flowrate (l/min.)	Shielding gas flowrate (l/min.)	Welding speed (cm/min.)
1.5	100	5	30	100
3.0	200	7	30	60
6.0	300	12	30	30
8.0	330	13	30	25

Submerged Arc Welding (SAW)

The SAW technique was developed simultaneously by the Lincoln Electric Company in the USA and by the B.E. Paton Institute in Kiev before the second world war. It is the automatic version that is the best known, in which one or several wire electrodes are melted, together under an powdered flux which forms a protective molten slag covering. Although the slag has a certain degree of electrical conductivity, melting is essentially due to the electric arc, resistance heating via the slag being only of secondary importance.

In the automatic process (fig. 3.1.14), the welding current can be very high, up to

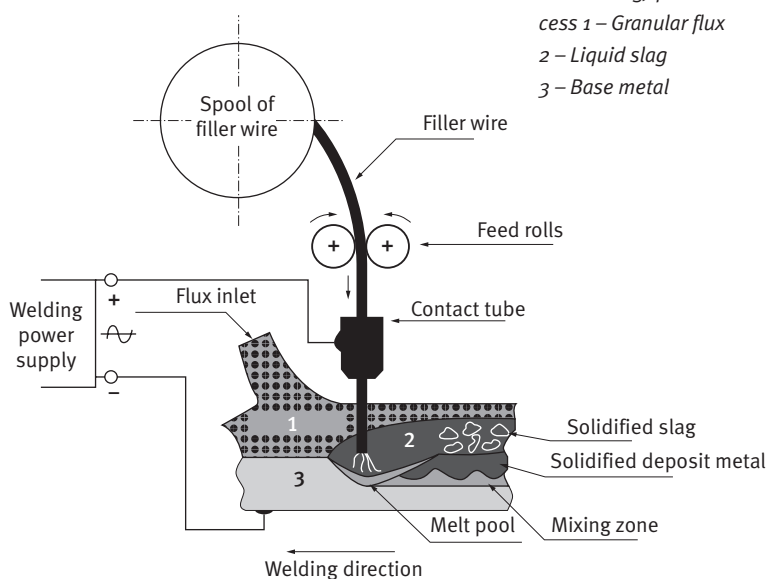

Fig. 3.1.14 - Principle of the SAW (Submerged Arc Welding) process 1 – Granular flux 2 – Liquid slag 3 – Base metal

2000 A per wire, leading to a large power input and consequently a heavy dilution of the base metal by the filler material (up to 80%). The power supply is generally of the DCEP reverse polarity type, and more rarely AC, when several wires are employed simultaneously, in order to avoid arc blow phenomena. For both DC and AC generators, the electrode wire pay-out speed must be equal to the melting rate in order to obtain a perfectly stable arc. This is obtained by the use of feed rolls commanded by a motor-reducing gear system with servocontrolled speed.

The choice of welding flux is also important, five types being available:

- Type 1: manganese silicate
- Type 2: calcium silicate
- Type 3: alumina-rutile
- Type 4: lime alumina
- Type 5: lime fluoride

For welding stainless steels, type 5 fluxes are most widely used, their typical composition being $25\% \leq \text{CaO} + \text{MgO} \leq 40\%$, $\text{SiO}_2 < 15\%$, $20\% \leq \text{CaF}_2 \leq 35\%$. They exist in two forms, produced either by melting or bonding. Fused fluxes are produced by heating to temperatures of the order of 1600–1700 °C, and are converted to powder form either by atomization on leaving the melting furnace, or by crushing and screening the solidified bulk material. Bonded fluxes are produced from raw materials of appropriate grain size, bonded together with an alkali silicate binder. The mixture obtained is dried, then mechanically treated, to obtain the desired final particle size. This intermediate product is then baked at a high temperature, which may exceed 700 °C in certain cases.

In the as-delivered condition, the fluxes are perfectly dry, giving diffusible hydrogen contents less than 5 cm³/100 g of metal deposited. In order to prevent moisture pick-up, it is recommended to store the flux at a temperature about 10 °C higher than that of the workshop, in an atmosphere whose relative humidity does not exceed 50%. If moisture pick-up is feared or suspected, it is useful to bake the powder at 300 °C for at least two hours. For baking to be efficient, the flux must be spread out on metal trays in a layer no more than 40 mm thick. The grain size of the flux is defined in terms of the sieve mesh dimensions. The mesh number is the number of mesh openings per unit length (usually per inch). The standard Tyler scale generally used for woven metal sieves starts at a value of 200 mesh, corresponding to 200 openings per linear inch (25.4 mm). The correspondence between mesh number and the (square) hole dimension is given in Table 3.1.6.

Table 3.1.6 - Correspondence between standard Tyler mesh number and hole dimensions (side of square)

Mesh number	Mesh opening (side of square – mm)
8	2.362
12	1.397
14	1.168
16	0.991
20	0.833
42	0.350
60	0.246
100	0.147
150	0.104
200	0.074

Two rules must be observed when choosing the grain size. First of all, except for horizontal welding positions (e.g. horizontal fillet, horizontal butt welds), it is recommended to use a fine grain size. Secondly, for procedures involving high welding currents, it is also recommend-

ed to use a fine grain size. The flux used plays an important role in the transfer of alloying elements from the filler metal to the melt pool, the effect being determined by the basicity index of the slag, which can be conveniently expressed by S.S. Boniszewski's formula:

$$B = \frac{[\text{CaO} + \text{MgO} + \text{Na}_2\text{O} + \text{K}_2\text{O} + \text{Li}_2\text{O} + \text{CaF}_2 + 1/2(\text{MnO} + \text{FeO})]}{[\text{SiO}_2 + 1/2(\text{Al}_2\text{O}_3 + \text{TiO}_2 + \text{ZrO}_2)]}$$

The higher the index, the greater the transfer of alloying elements. Silica, SiO_2 , reacts with chromium, retaining it in the slag in the form of oxides. Rutile, TiO_2 , does the same, albeit to a lesser extent. With fluxes whose basicity index is less than 1, up to 30% of the chromium can be oxidized in this way. On the contrary, with high basicity fluxes ($B > 3$), chromium losses will be less than 10%, and can be readily compensated by additions of ferrochrome in the flux. Nickel and molybdenum have a lower tendency to oxidize, and therefore have a good transfer coefficient in the arc.

Since the SAW process is used mainly for thick austenitic stainless steel sheet, particular care must be taken to avoid the formation of sigma phase due to the use of

high welding energies. This is especially the case for 25% Cr-20% Ni alloys, but also for 18% Cr-9% Ni grades with high ferrite contents. In multipass welding, where the temperature range 650–900 °C is crossed several times, the risk of sigma phase formation is considerably enhanced. Subsequent solution annealing at 1050 °C is then highly recommended.

The recommended welding parameters as a function of electrode wire diameter and flux grain size are indicated in Table 3.1.7.

Table 3.1.7 - Recommended welding parameters as a function of electrode wire diameter and flux grain size

Electrode wire diameter (mm)	Welding current (A)	Arc voltage (V)	Flux grain size (mesh)
2.4	250 – 500	22 – 32	8 × 48
3.2	300 – 700	23 – 36	14 × 48
4.0	400 – 900	24 – 40	16 × 150
5.0	500 – 1100	25 – 43	42 × 200

Shielded Metal Arc Welding (SMAW)

Although the SMAW process is very old, since the first applications were reported by Kjellberg in 1907, it remains widely used due to its great flexibility and simplicity of implementation. As illustrated schematically in figure 3.1.15, the electrode consists of a metal core covered with a layer of flux. The core is usually a solid stainless steel wire, but in certain very special cases it can be a cored wire or a solid mild steel wire (“synthetic” electrodes). The covering, which plays an essential role in the process, is extruded onto the core, and gives each electrode its specific “personality”. It serves three main functions – electrical, physical and metallurgical. The electrical function is related to initiation and

stabilization of the arc, while the physical influence concerns the viscosity and surface tension of the slag, which control the transfer of metal droplets, the effective shielding of the melt pool and its wettability, and the aptitude for in situ welding (e.g. in the vertical up butt and horizontal butt welds). The metallurgical role involves chemical exchanges between the melt pool and the slag, i.e. refining of the deposited metal. The covering contains a certain amount of calcium carbonate (CaCO_3), which dissociates in the arc at about 900°C , to form CaO and CO_2 , the latter ensuring protection of the arc zone. Finally, as in the SMAW process applied for to mild steel, in addition to refining reactions, the slag enables the addition of elements not contained in the core, or present only in small amounts.

Rutile-covered electrodes can be employed in both the AC and DC modes, whereas lime coverings are used essentially in the DCEP reverse polarity mode. The recommended welding parameters for electrodes depositing either a 17% Cr or 19% Cr-10% Ni composition are indicated in Table 3.1.8.

Fig. 3.1.15 - Principle of the (S.M.A.W.: Shielded Metal Arc Welding) process
 1 – Solidified deposit metal
 2 – Mixing zone
 3 – Flux covering
 4 – Electrode core

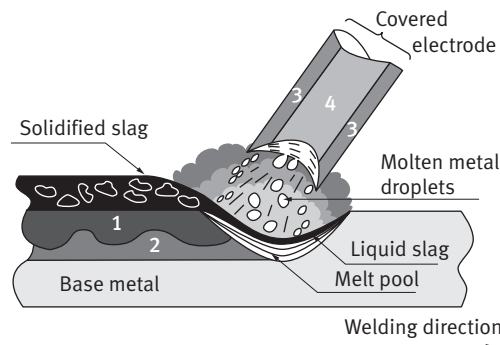

Table 3.1.8 - Recommended SMAW parameters as a function of electrode core diameter

Core diameter (mm)	Welding current (A)	
	17% ferritic weld deposit	19% Cr-10% Ni austenitic weld deposit
2.5	50 – 100	40 – 90
3.2	80 – 110	60 – 100
4.0	110 – 160	90 – 150
5.0	150 – 230	130 – 220

Electrical resistance welding

Resistance Spot Welding (RSW)

This process is still extensively used and is particularly suited to the welding of thin stainless steel sheets. Melting is induced by resistance heating due to the passage of an electric current through the workpiece materials at the joint. Five different stages are generally distinguished in the spot welding process (fig. 3.1.16), namely, positioning of the sheets to be joined, low-

ering of the upper electrode and application of the clamping force, welding with a low voltage alternating current, producing a heating energy W (joules) = R (ohms) I^2 (amps)² t (seconds), holding of the clamping force or application of an additional forging force, and finally, raising of the upper electrode before proceeding to the next cycle.

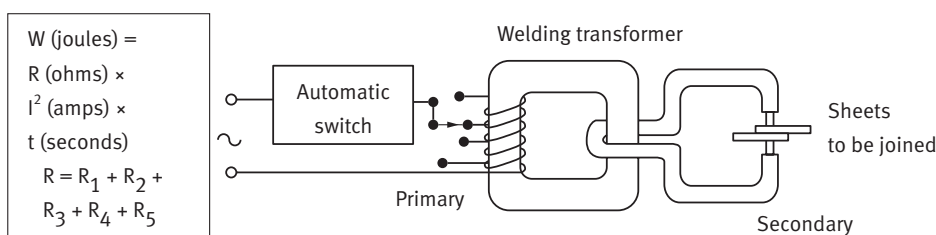
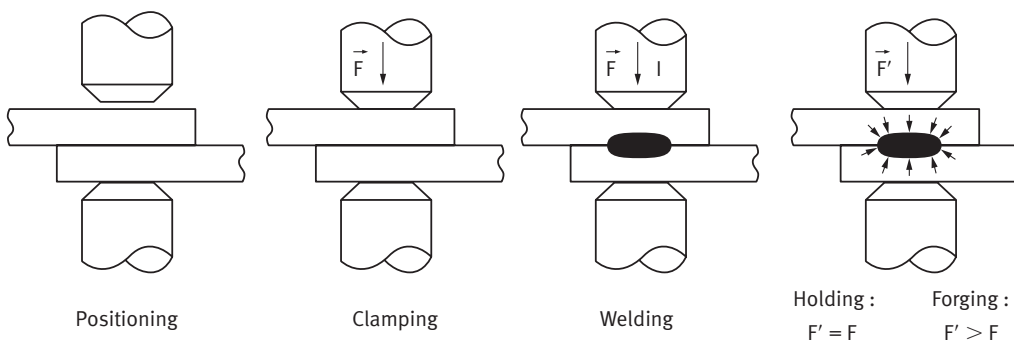
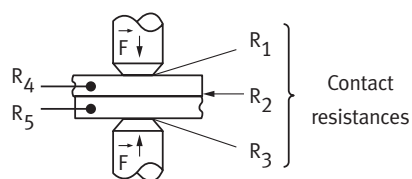

Fig. 3.1.16 - Principle of resistance spot welding

R_4 and R_5 : Resistances of the workpiece sheets (depend on their resistivities)
 R_2 : Contact resistance between the 2 sheets depends on their surface conditions and the clamping force \vec{F}
 R_1 and R_3 : Contact resistances between the electrodes and the sheets



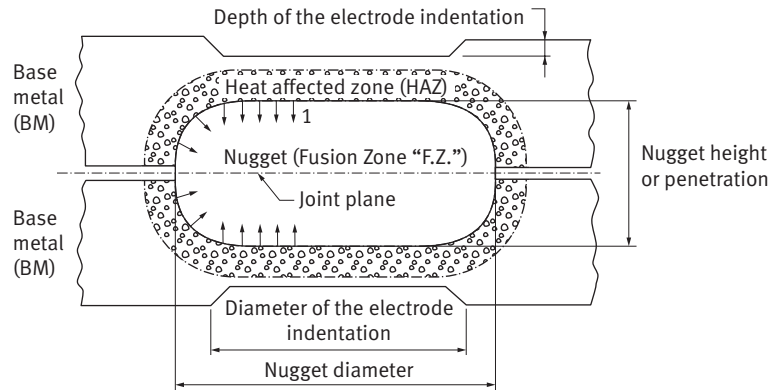

Fig. 3.1.17 - Schematic representation of a weld spot and nugget formation. 1 – Schematic representation of dendrite formation

With regard to the electrode materials, in the case of stainless steels, the best combination of low resistivity and high mechanical strength is obtained with copper-cobalt-beryllium alloys. The electrode points are generally in the form of a truncated cone with an apex angle of 120°. Formation of the weld nugget (fig. 3.1.17) depends on the welding current and its duration, and on the clamping force applied by the electrodes. The welding parameters recommended for 18% Cr-9% Ni austenitic stainless steel and stabilized 17% Cr ferritic grades are indicated in Table 3.1.9.

The parameters given in Table 3.1.9 must be optimized to allow for the surface condition (pickled-2D, 2B, bright annealed-2R), which has a strong influence on the interface resistance, which in turn plays a decisive role in nugget formation. Contrary to other fusion welding processes, in resistance spot welding, the melt pool cannot be controlled visually. The only defects perceptible to the eye are an excessive electrode indentation and surface spatter. However, a simple, albeit destructive, inspection method is the so-called “peel test”, which gives a rapid indication of the quality of the weld spot.

Table 3.1.9 - Recommended resistance spot welding parameters for 18% Cr-9% Ni austenitic stainless steel and stabilized 17% Cr ferritic grades

Sheet thicknesses (mm)	Electrode tip diameter (mm)	Electrode clamping force (daN)	Welding current (A)	Welding time (No of periods)
18% Cr - 9% Ni austenitic grades				
0.5	3.0	170	3500	3
0.8	4.5	300	6000	4
2.0	6.0	650	11000	8
Stabilized 17% Cr ferritic grades				
0.5	3.0	150	4000	3
0.8	4.5	250	7550	4

Resistance Seam Welding (RSEW or SW)

The principle of resistance seam welding is similar to that of spot welding, except that the process is continuous. The major difference is in the type of electrodes, which are wheels equipped with an appropriate drive system (fig. 3.1.18 and 3.1.19). Compared to spot welding, where the principal process parameters are the welding current, the application time and the electrode clamping force, additional factors to be considered in seam welding are the use of a modulated or pulsed current and the welding speed (the linear wheel velocity entrains the sheet travel displacement). The most widely used material for the electrode wheels is a copper base alloy containing cobalt and beryllium to improve the mechanical strength. The wheel edges usually have either a double chamfer or a convex profile. The welding parameters recommended for Fe-Cr-Ni austenitic grades are indicated in Table 3.1.10.

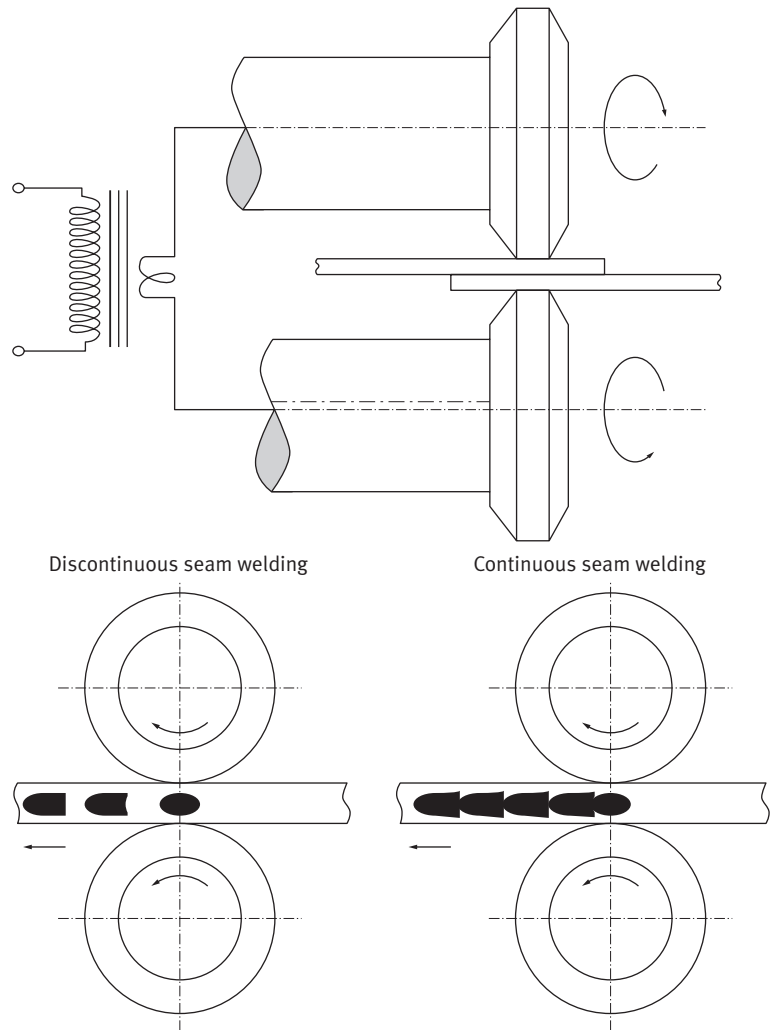
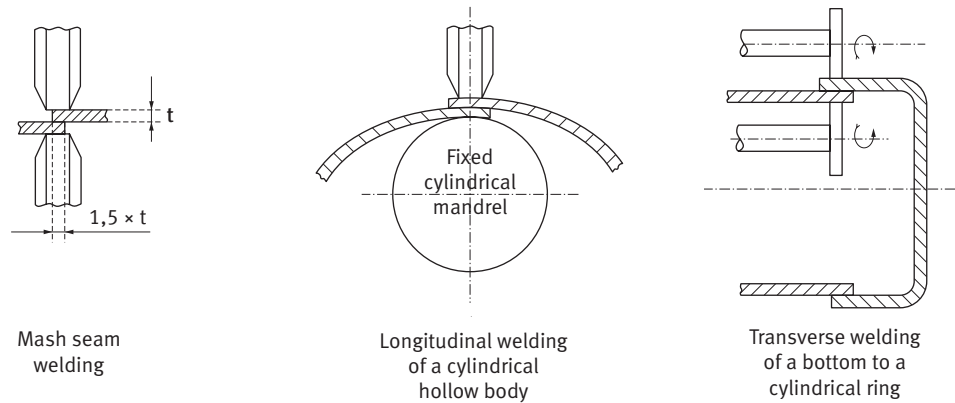

Fig. 3.1.18 - Principle of resistance seam welding

Fig. 3.1.19 - Typical assemblies produced by resistance seam welding



Mash seam welding

Longitudinal welding of a cylindrical hollow body

Transverse welding of a bottom to a cylindrical ring

Table 3.1.10
-Recommended resistance seam welding parameters for 18% Cr - 9% Ni austenitic stainless steels

Sheet thicknesses (mm)	Wheel thicknesses (mm)	Clamping force (daN)	Welding time (periods)	Rest time (periods)	Welding current (A)	Welding speed (cm/min.)
0.5	3.0	320	3	2	7900	140
0.8	4.5	460	3	3	10600	120
1.5	6.5	800	3	4	15000	100
2.0	8.0	1200	4	5	16700	95
3.0	9.5	1500	5	7	17000	95

Table 3.1.10 shows the necessity of modulating the welding current. The distance between successive nuggets is determined by the pulse frequency (welding time and rest time) and the welding speed (tangential wheel velocity). The welding time is chosen as a function of the steel grade and the sheet thicknesses, while the rest time is determined by the welding speed.

In both spot and seam welding, the major advantages of resistance heating are the limited modification of the microstructure in the heat affected zones, the virtual absence of surface oxidation if the sheets are correctly cooled (by streaming cold water), and the very small distortion of the sheets after welding.

Variants of resistance welding

Upset welding (UW)

Upset welding, or resistance butt welding (fig. 3.1.20 and 3.1.21) is used essentially for long products (rods, bars, tubes, shaped sections, etc.). The two end faces to be joined must make excellent contact to facilitate passage of the heating current, which is fed to the workpiece components through the fixed and mobile clamp. The current produces intense heating in the region between the clamps, with a local excess temperature at the interface, due to the additional contact resistance. When the temperature is sufficient, an upsetting force is applied between the two clamps, in order to induce forge welding without melting. Since the upsetting force is high,

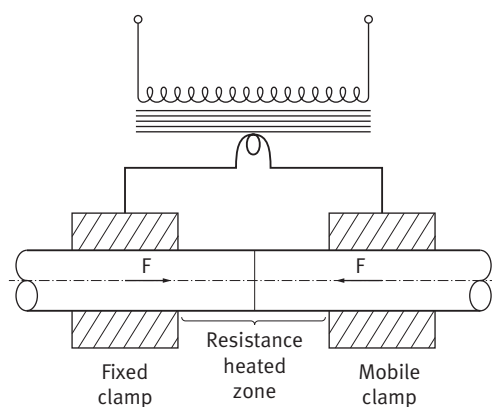

Fig. 3.1.20 - Principle of upset welding

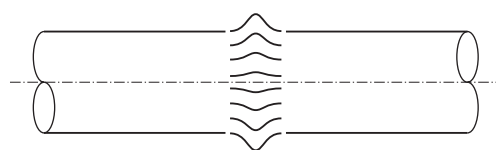

Fig. 3.1.21 - Upset welding of a cylindrical bar

the cross-section of the parts must be sufficiently large to avoid buckling. After welding, a marked swelling is observed in the weld zone. This process is very old, being described by Elihu Thomson in 1887, but has now been largely replaced by flash butt welding, which is much more flexible.

Flash welding (FW)

Although apparently similar to upset welding, flash butt welding is in fact quite different (fig. 3.1.22, 3.1.23 and 3.1.24). Indeed, during upset welding, it had been observed that when the abutting surfaces were not in perfect contact, the current passed only in a few small areas, leading to intense local heating and rapid melting, creating arcs which violently expulse the molten metal out of the joint due to the associated magnetic fields (the flashing phenomenon). The important process parameters are the welding current and the voltage, which must be sufficient to cause flashing, the instantaneous flashing speed, which is proportional to the metal consumption and compensated by the displacement of the mobile clamp, the duration of flashing, and the final upset forging stage. The roughness of the initial facing surfaces must be such that the contact points are sufficiently numerous and well distributed to produce uniform flashing across the whole of the joint area (fig. 3.1.23). After upset forging, the joint profile should show the characteristic three-finned profile indicative of a successful welding operation (fig. 3.1.24).

In spite of its limitations, upset welding is still used for joining coils to facilitate continuous wire drawing up to 8.0 mm diameter.

Fig. 3.1.22 - Principle of flash butt welding

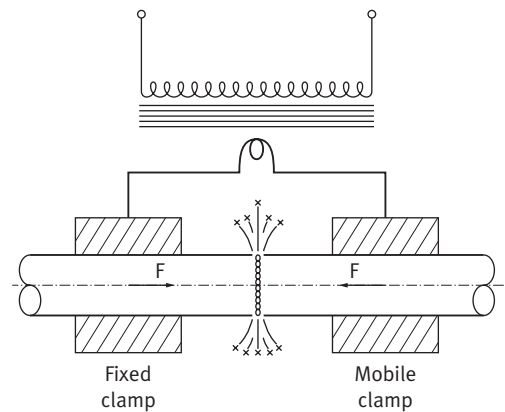
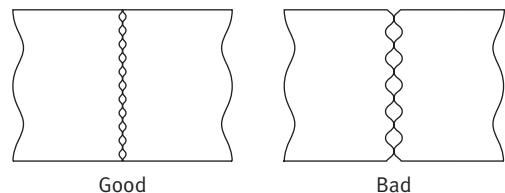
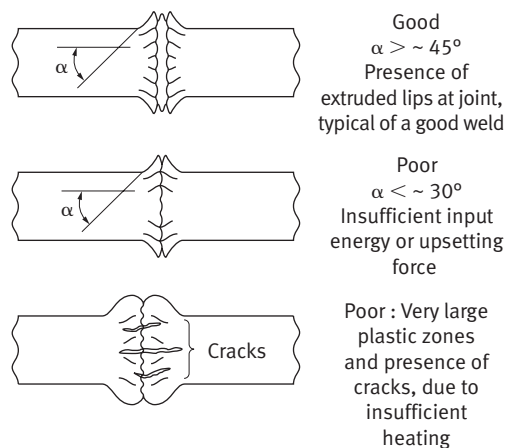

Fig. 3.1.23 - The asperities on the 2 facing surfaces must be symmetrical with respect to the plane of the joint.



– An optimum flashing energy produces numerous small craters (left),
 – while an excessive flashing energy leads to fewer and deeper craters (right).

Fig. 3.1.24 - Effect of welding parameters on the final weld profile



High Frequency Induction Welding (HFIW)

High frequency induction welding (fig. 3.1.25) is essentially used for making tubes from strip. The process is performed on a continuous line in which the welding station is preceded by a multiple roll forming system. On leaving the last rolling stand, the tube comprises a longitudinal slit which is closed by welding. The joint is formed by solid-solid contact, with intermediate melting, as the strip edges are brought together by a pair of horizontal rolls (squeezing rolls). Due to the skin effect, the induced HF current (140 to 500 kHz) follows paths of minimum impedance, concentrating the heating at the edges (fig. 3.1.25).

In the case of ferritic stainless steels, this high productivity process avoids the grain coarsening phenomenon to which these grades are susceptible. In this case, welding powers between 150 and 300 kW are employed, depending on the tube diameter, the welding speed varying with the machine from 50 to 90 m/min.

Fig. 3.1.25 - Principle of HF induction welding

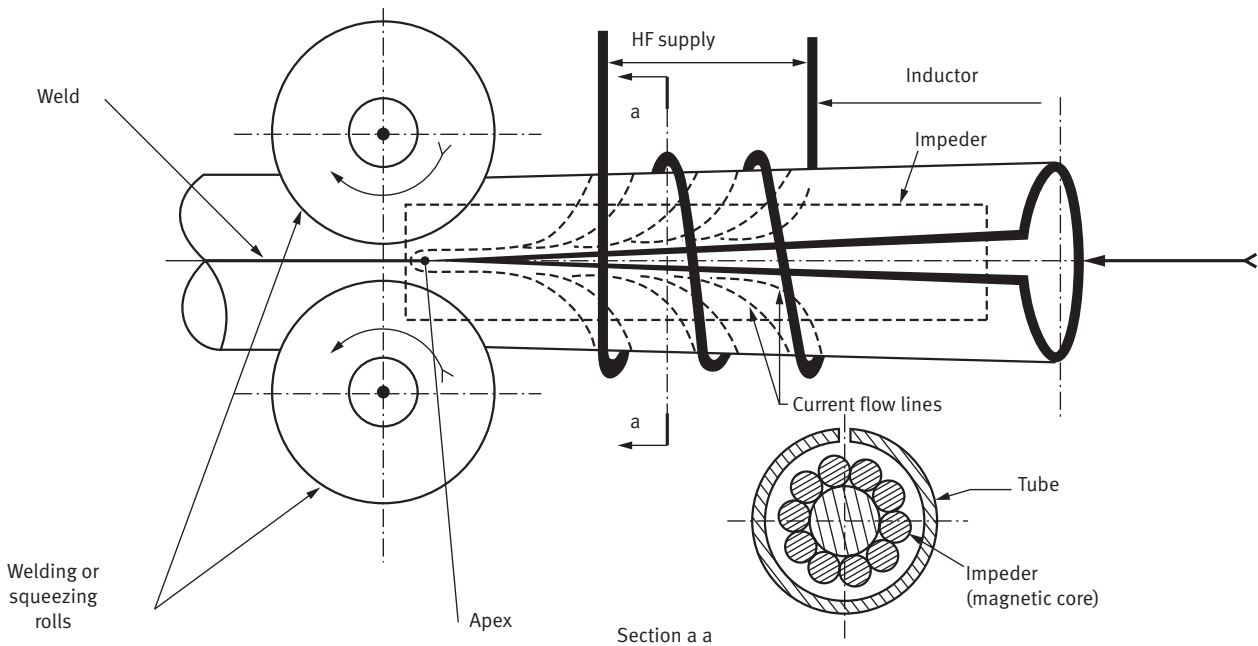

Laser Beam Welding (LBW)

The laser effect (Light Amplification by Stimulated Emission of Radiation) was discovered in the optical wavelength range by Maiman in 1958. The possibility of using a laser beam as a small area contact-free high intensity power source immediately appeared attractive for welding applications, particularly since no vacuum is required, contrary to electron beam welding. The set-ups employed for solid state and gas laser welding are illustrated schematically in figures 3.1.26 and 3.1.27 respectively.

ly. The continuous power levels available are particularly high for carbon dioxide lasers, although it must be remembered that the effective welding power depends on the reflectivity of the work-piece material for a given incident wavelength.

The sources most widely used for welding purposes are CO₂ gas lasers and solid state yttrium-aluminum garnet (YAG) lasers. YAG lasers are preferred for welding thin stainless steel sheets (< 1.5 mm) in the pulsed mode. So-called CO₂ lasers, in which

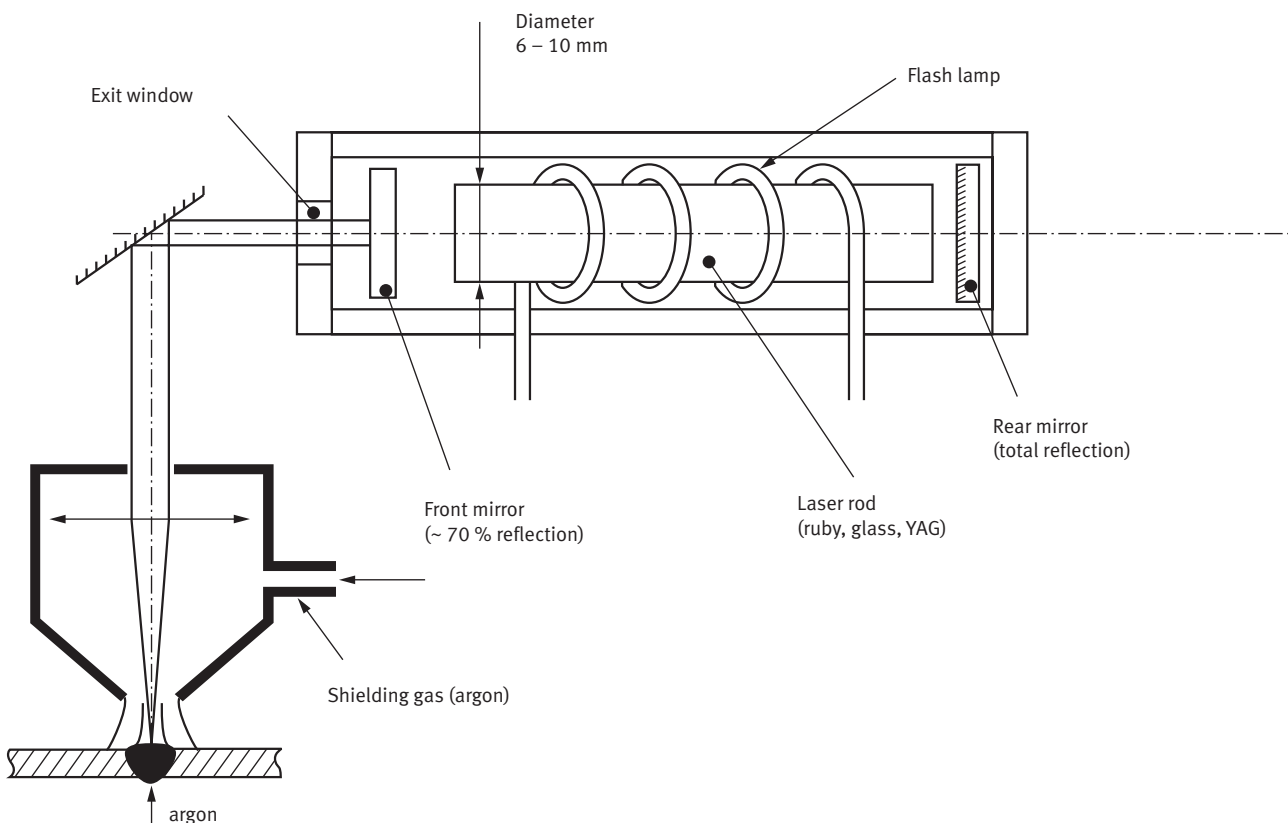

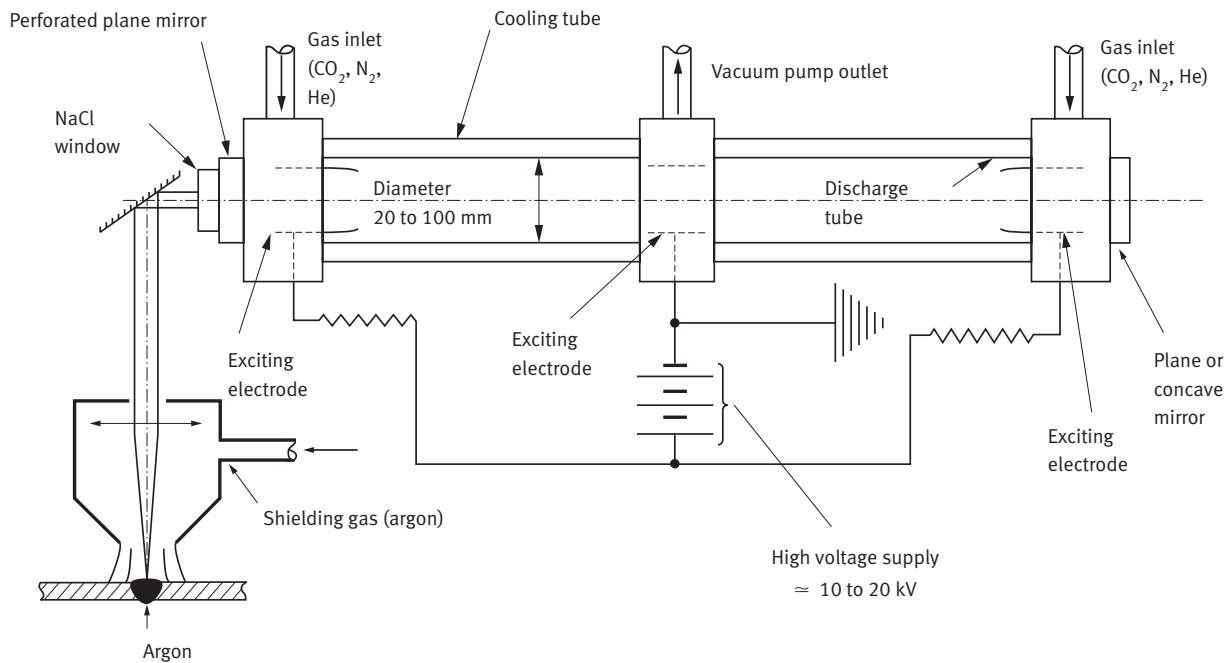

Fig. 3.1.27 - Principle of a CO₂ (CO₂, N₂, He) laser used for welding

the lasing gas is in fact a CO₂-N₂-He mixture, are better adapted for the welding of thicker stainless steel sheets (1.5 to 6.0 mm).

As in high frequency induction welding, this process is widely used for the production of longitudinally welded tubes. With a power of about 6 kW, a 2 mm thick strip of

stabilized 17% Cr ferritic stainless steel can be welded at a speed of the order of 7 m/min, and since the thermal cycle is very brief, grain coarsening in the heat affected zone is extremely limited.

Other welding processes

It is impossible to give an exhaustive coverage of all the welding processes applicable to stainless steels. One of the most noteworthy is electron beam welding, which must be performed under vacuum, but enables the production of highly precise joints in both thin and heavy gage materials. Finally, friction butt welding can sometimes be useful for joining long products (bars). In this process, one of the components to be joined

is rapidly rotated and then brought into contact with the other fixed one under controlled pressure. The resulting intense friction causes welding due to limited surface melting and diffusion bonding.

Finishing treatments for welding austenitic stainless steels

Pickling

With certain welding processes, the welded joint (including the heat affected zone) becomes covered with a coloured oxide which it is essential to remove in order to be able to restore passivity. Several techniques can be employed.

Pickling baths

- 52% nitric acid (36° Baumé) : 100 l
- 65% hydrofluoric acid : 20 l
- or sodium fluoride : 30 kg
- water : 900 l

The immersion times at 20 °C generally vary between 1 and 3 hours. The bath temperature and immersion time must be carefully controlled to prevent corrosion of the metal. After pickling, the parts must be abundantly rinsed with chlorine-free water.

Pickling pastes and gels

The use of pastes or gels enables the treatment to be limited to the weld zones. Their compositions vary, but often contain nitric acid. The paste or gel is spread on with a paint brush, and the area is then brushed with a stainless steel wire brush. After pickling, the affected area is rinsed with chlorine-free water.

Passivation

After pickling, the metal is unprotected and a new passive layer must be formed to restore its corrosion resistance. To a certain extent, this occurs spontaneously after pickling and rinsing. However, in order to ensure the quality and speed of passivation, an immersion in a passivating bath is recommended.

Passivating baths

The parts are immersed in an acid bath with the following approximate composition:

- 52% nitric acid (36° Baumé) : 250 l
- water : 750 l

The immersion times at 20 °C generally vary between 15 minutes and 1 hour. After passivation, the parts are carefully rinsed with chlorine-free water.

Passivating pastes and gels

Pastes and gels are used for local passivation of the weld zones. The nitric acid based product is spread on the surfaces to be treated, then totally eliminated by brushing with a stainless steel or nylon brush, followed by rinsing with chlorine-free water.

Decontamination

The different sheetworking operations (shearing, bending, forming, etc.) can leave iron-rich particles on the surface, which it is essential to remove. Although their aim is different, the methods used for decontamination are the same as those for passivation.

3.2 Brazing and soldering

Introduction

Brazing and soldering are techniques for joining metallic components in the solid state by means of a fusible filler metal with a melting point well below those of the base metals. Soldering employs soft filler al-

loys with melting points less than 450 °C, whereas brazing alloys are harder and melt at higher temperatures. Since the base metals remain in the solid state, it is essential to obtain perfect wetting by the molten filler material (fig. 3.2.1).

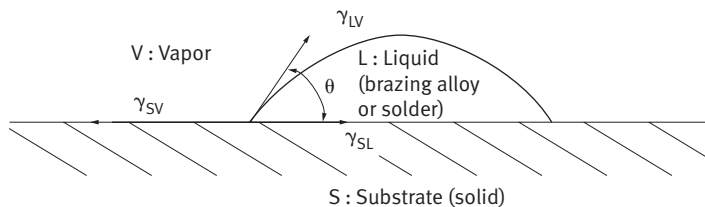

Contact angle : $\theta < 90^\circ \rightarrow$ good wetting of the substrate by the molten brazing alloy or solder

Young's model : $\gamma_{SV} = \gamma_{SL} + \gamma_{LV} \cos\theta$

γ_{LV} : Surface tension of the liquid brazing alloy or solder in equilibrium with its vapor (mN/m)

γ_{SV} : Surface tension of the solid substrate in equilibrium with the brazing alloy solder vapor (mN/m)

γ_{SL} : Interface tension between the liquid brazing alloy or solder and the solid substrate (mN/m)

Fig. 3.2.1 - Wetting of the substrate by the brazing alloy or solder

Brazing

Heating process

The heating process employed depends both on economic considerations and on the type of assembly to be produced. Whatever the technique chosen, it is recommended to observe the following two basic rules:

a) Heating must be rapid to ensure uniform melting of the brazing alloy rather than liquation, and also to prevent microstructural changes in the base metals.

b) The joint must be heated to a uniform temperature slightly above the liquidus of the brazing alloy employed.

The principal heating processes employed are:

- oxyacetylene torch heating;
- high frequency (HF) and medium frequency (MF) induction heating;
- heating in a continuous or muffle furnace;
- immersion heating;
- heating with a soldering iron (for solders, not for brazing).

Oxyacetylene torch heating

The parts to be joined must be previously protected by a flux, generally in the form of paste. The flame must be neutral towards the base metal, i.e. neither carburizing nor

oxidizing. When the brazing alloy has a wide melting range ($> 50^\circ\text{C}$), it is important to heat the parts to be joined to a uniform temperature to avoid liquation (partial melting).

Induction heating

This is probably the most suitable heating process for the series brazing of parts with complex geometries. However, it is absolutely essential that the shape of the induction coil is well adapted to those of the parts to be joined. This is also true for the shape of the brazing material, which may be in the form of rings, disks, etc. Induction heating of both the base metals and brazing alloy is rapid, typically taking about 30 seconds. Either medium frequency (several tens of kHz) or high frequency (300-500 kHz) generators are used, MF heating being more appropriate for medium to heavy gage components, whereas HF induction is to be preferred for thinner parts. Indeed, the depth of penetration of the heating depends on the frequency, and is given by the formula:

$$p = k \times \sqrt{\rho / \mu \times f}$$

where p is the depth of penetration, f is the frequency, μ is the magnetic permeability, ρ is the electrical resistivity and k is a proportionality coefficient. Practically 90% of the heat is generated in the surface layer of thickness p . Since the magnetic permeability μ and the electrical resistivity ρ of the base metals are essentially constant, the penetration p is inversely proportional to the square root of the frequency. Induction heating is more efficient for parts with circular symmetry. The most characteristic applications employ helicoidal, spiral or circular external coils or helicoidal internal ones (fig. 3.2.2). For relatively low melting point brazing alloys, heating can be performed in air, but it is necessary to use a protective pickling flux, all traces of which must imperatively be removed after brazing. Heating in a neutral or reducing atmosphere minimizes oxidation.

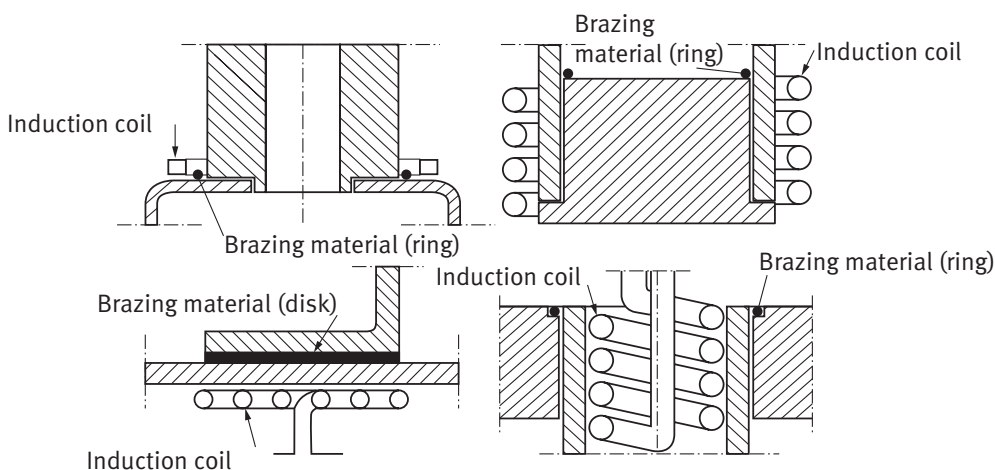

Fig. 3.2.2 - Induction systems for brazing

Furnace heating

The austenitic stainless steels (Fe-Cr-Ni alloys) can be readily brazed. The brazing materials employed are either copper-base, silver-copper-zinc-tin, nickel-chromium-boron or nickel-chromium-silicon alloys. Ferritic stainless steels (Fe-Cr alloys) are commonly brazed with silver-copper-tin-nickel, silver-copper-zinc-nickel or silver-copper-zinc-tin alloys, using similar procedures to those for austenitic grades. The major difference for ferritic materials is the need to scrupulously respect the recommended brazing temperature and time, in order to avoid excessive grain growth and/or chromium carbide precipitation.

In a continuous or muffle furnace, heating is produced either by combustion of a hydrocarbon fuel or by electrical resistances. In order to avoid oxidation of the stainless steel, the brazing operation itself is performed under vacuum or in a controlled atmosphere, preferably of a reducing nature, such as dry hydrogen or a hydrogen-nitrogen mixture, generally produced by cracking ammonia. In order to ensure a low oxidizing potential, the moisture levels must correspond to dewpoints of at least $-55\text{ }^{\circ}\text{C}$, and if possible $-70\text{ }^{\circ}\text{C}$. Depending on the brazing alloy employed, the furnace temperature may be between 600 and $1200\text{ }^{\circ}\text{C}$, with heating rates of the order of 15 to $20\text{ }^{\circ}\text{C}/\text{min}$.

Cooling may be performed initially under vacuum, then at an accelerated rate, in either a reducing atmosphere (austenitic grades) or a neutral argon atmosphere (ferritic grades), in order to avoid oxidation. In all cases, the holding time at the brazing temperature

must not be extended beyond that strictly necessary for the joining operation, involving good wetting of the base metals by the braze material, a few minutes generally being sufficient.

The use of stabilized ferritic stainless steels is currently undergoing rapid development. Brazing of these materials under vacuum or protective gas requires specific procedures and filler products, since the stabilizing elements can have a detrimental effect on wettability. The atmospheres most commonly employed in this case are pure hydrogen, hydrogen-10% nitrogen, hydrogen-25% nitrogen and vacuum. Of the two stabilizing elements most frequently used, niobium has virtually no influence on wetting behaviour, whereas titanium has a pronounced negative effect, particularly in concentrations exceeding those strictly necessary for stabilization. The new brazing alloys used for these grades are Cu-30% Mn-5% Ni and Cu-30% Mn-5% Ag alloys, applied at temperatures of the order of $1000\text{ }^{\circ}\text{C}$, either in a vacuum of 10^{-5} torr, or under an atmosphere of pure hydrogen with a dewpoint of $-60\text{ }^{\circ}\text{C}$.

The heating techniques summarized above are essentially applicable only to brazing, the corresponding brazing alloys being indicated in Table 3.2.1 for the three major families of stainless steels, i.e. austenitics, ferritics and martensitics.

Soldering

Two types of solder are used for stainless steels, corresponding to either almost pure tin, with a melting point of about 230 °C and a tin-silver alloy with a melting range of 215–225 °C (fig. 3.2.3). Austenitic alloys of the 18% Cr-9% Ni type have excellent solderability, while 17% Cr ferritic grades require prior surface preparation. For both austenitic and ferritic alloys stabilized with titanium and/or niobium, soldering is somewhat more difficult without careful surface conditioning. Indeed, as in any wetting phenomenon, surface finish has a decisive influence. A pickled finish (2D) is more suitable than either a 2B surface finish, or especially a bright annealed finish (2R), Table 4.1.2.

Soldering is generally performed with an electric soldering iron, but an oxyacetylene torch may also be employed. Soldering requires the use of a suitable flux, which in the case of stainless steels must not contain chlorine, whose corrosive effect is well

established. Orthophosphoric acid based fluxes give excellent results and avoid the risks associated with chlorides. In all cases, the stainless steel surfaces must be thoroughly rinsed after soldering to remove all traces of flux.

An excellent way to obtain virtually perfect soldered joints is to use austenitic or ferritic stainless steels with controlled surface roughness. These products are widely used for roofing and accessories in the building industry, and have a matt appearance, often greatly appreciated by architects.

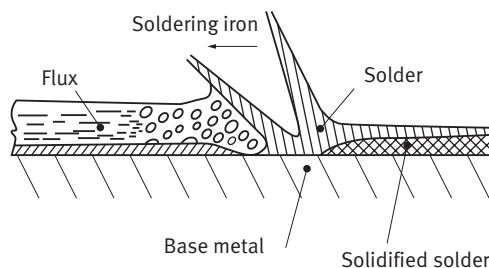

Fig. 3.2.3 - Principle of soldering

Table 3.2.1 - Principal brazing alloys used for stainless steels

Classification ASTM - AWS	EN 1044 short code	Nominal composition (wt. %)									Brazing temperature (°C)	Base metal*			
		Ag	Cu	Ni	Zn	Cr	Si	Sn	Cd	Others		A	F	M	
BAG 1	Ag 302	45	15		16						24	620 / 730	X		
BAG 1 a	Ag 301	50	15.5		16.5						18.0	630 / 760	X		
BAG 4		40	30	2	28							780 / 900	X		X
BAG 13		54	40	1	5							860 / 970	X	X	X
BAG 21		63	28.5	2.5						6		800 / 900	X	X	X
BAG 26		25	38	2	33						Mn=2	800 / 900	X		
BNI 1	Ni 101			74.1		14	4.0				B=3.4 Fe=4.5	1070 / 1200	X		
BNI 2	Ni 102			82.4		7	4.5				B=3.1 Fe=3.0	1010 / 1180	X	X	
BNI 5	Ni 105			71		19	10					1070 / 1200	X	X	

* A: austenitic, F: ferritic, M: martensitic.

3.3 Adhesive bonding

Introduction

Adhesive bonding can be employed to reinforce mechanical joints produced by bolting, riveting, clinching, etc., and can also be used in its own right for joining thin stainless steel sheets when it is essential not to modify the surface appearance. Adhesive bonding operations do not modify the joint geometry and cause no microstructural changes in the metallic alloys. Correctly designed adhesively bonded joints have excellent fatigue strength. In certain cases, the adhesive layer can provide thermal and electrical insulation and may also absorb vibrations, decreasing noise levels. The use of adhesive bonding frequently enables significant weight savings, which are particularly

advantageous in transport applications. These undeniable advantages are offset by the mechanical properties of the joints, which are generally weaker than those produced by welding or brazing, together with a temperature limit usually of about 200 °C and a certain sensitivity to moisture. Finally, for successful adhesive bonding, it is essential to work with perfectly clean and well prepared surfaces.

The major families of adhesives

An adhesive is a complex product, each of whose many components has a specific function (plasticizer, hardener, solvent, etc.).

These constituents are mixed according to various formulations designed to produce different property combinations.

Classification according to physical type

The physical forms of adhesives may be liquids, pastes, powders, tapes, films, etc.

Liquid adhesives

These materials are often solvated and must then be dried. In this case, they are supplied either as aqueous or organic solvent solutions or in the form of emulsions. They may also be hot or cold polymerizing single- (1 K) or two-component (2 K) resins.

Pastes and mastics

These products are single- (1 K) or two-component (2 K) resins which ensure adherence and sealing after drying and/or crosslinking (i.e. curing, setting, hardening).

Powdered or granulated adhesives

These products are solid at ordinary temperatures and acquire their adhesive properties by heating.

Adhesive films and tapes

Single or double-sided adhesive films/tapes are available, in which a synthetic support is impregnated with adhesive on one or both sides. Alternatively, the

adhesive itself may be transferred from a support onto the surface to be bonded, or the entire film may polymerize by heating to produce bonding.

Classification according to the setting mechanism

According to this classification, three major categories of adhesives can be distinguished, corresponding to thermosets, thermoplastics and cold bonding materials, elastomers being affiliated to the latter group.

Thermosetting adhesives

In these products, the setting or curing kinetics are very slow at ambient temperature and are accelerated by heating or by adding a hardener prior to use. They include phenolics, epoxies (epoxy plus polyamides, nylon, silicone, polysulfides, phenolics), acrylics (cyanoacrylates, anaerobic and modified acrylics) and aminoplastics (urea-formol).

Thermoplastic adhesives

These products soften by heating then harden again on cooling, the reaction being reversible (contrary to thermosets). They include adhesives based on ethyl vinyl acetate (EVA) and vinyl ethylene, organic solvent-based adhesives (neoprenes, and other rubber and polyurethane elastomer-based adhesives) and water soluble adhesives (vinyls, acrylics, epoxies and polyesters).

Mastics

These products polymerize in contact with atmospheric moisture, and include silicone and polyurethane types.

Adhesion

Adhesion mechanisms

Numerous theories exist concerning the mechanisms of adhesion, namely the mechanical, electronic, diffusion, thermodynamic and chemical theories. None of them alone can explain all aspects of adhesion. However, it appears that the mechanical

theory, based on keying of the adhesive to surface micro-asperities, together with the thermodynamic theory involving so-called Van der Waals bonds, are most representative of the phenomena observed in practice.

Surface wetting

The essential condition for good bonding is satisfactory wetting of the substrate by the adhesive. The ability of an adhesive to wet a surface depends on the surface tensions of the adhesive and substrate (γ_a and γ_s respectively), and also on the interface tension between the adhesive and the substrate (fig. 3.3.1). In practice, for the adhesive to

correctly wet the surface of a substrate (i.e. to spread out over it, so that $\theta \mapsto 0$ and $\cos \theta \mapsto 1$), the surface tension of the substrate must be greater than that of the adhesive, i.e. $\gamma_s > \gamma_a$.

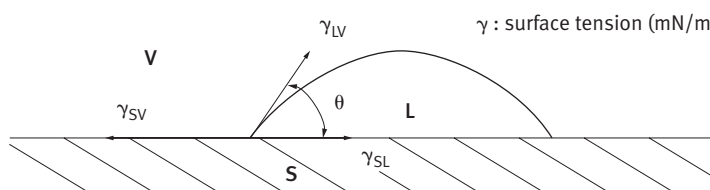

S : Substrate (solid) – V : Adhesive vapor – L : Liquid (adhesive)

γ_{LV} : Surface tension of the liquid adhesive in equilibrium with its vapor (mN/m)

γ_{SV} : Surface tension of the solid substrate in equilibrium with the adhesive vapor (mN/m)

γ_{SL} : Interface tension between the liquid adhesive and the solid substrate (mN/m)

Young's model : $\gamma_{SV} = \gamma_{SL} + \gamma_{LV} \cos \theta$

Contact angle : $\theta < 90^\circ \rightarrow$ good wetting of the substrate by the adhesive

Fig. 3.3.1 - Wetting of a substrate by an adhesive

Bonding procedures

Surface preparation

In order to promote bonding, all substances liable to chemically or physically reduce wetting must be eliminated, and if possible, the surface treatment should even improve the intrinsic wettability. This is

mainly achieved by mechanical means such as sandblasting, grinding, etc., by chemical treatments such as pickling or anodizing, or by combinations, for example, sandblasting followed by application of a bonding primer.

Application of the adhesive to the substrate

The technique to be employed depends on the physical and chemical nature of the adhesive. Available methods include ap-

plication with a roller or brush, spray coating and casting.

Joining

The two surfaces are brought together, taking great care to avoid creating any discontinuity in the adhesive film.

Setting or curing

The adhesive can set or harden in different ways, including at room temperature or on heating, in either case with or without

applied pressure, or due to the effect of ultraviolet radiation at ambient temperature.

Advantages of adhesive bonding for stainless steels

As indicated in the introduction, adhesive bonding is a useful technique for joining stainless steels, since it modifies neither the microstructure nor the geometry, and what is probably even more important, does not alter the appearance. However, the strength of the joints obtained is not comparable to those produced by welding or brazing. Thus, the shear stress of an adhesively bonded joint typically varies from 1 to 30 N/mm²,

whereas for a welded joint values of about 500 N/mm² are obtained, whatever the stress direction. Because of this, adhesive bonding is always used to produce lap joints, with the load being spread over a sufficiently large area to appropriately limit the stresses. Furthermore, for reliable behaviour, the joint must be loaded only in the tensile shear mode.

Preparation of stainless steel surfaces

The passive layer on a stainless steel is composed mainly of oxides and hydroxides of iron and chromium, but can be contaminated by various foreign elements that are

detrimental to good adhesion. It is therefore necessary to prepare the surface so as to ensure good wetting by the adhesive (cf. the section “surface wetting”).

Mechanical surface preparation

The aim of mechanical surface treatments is to increase the roughness and enhance keying. This is obviously only effective if the adhesive satisfactorily wets the asperities produced. The techniques most commonly employed are sandblasting with abrasive silica or alumina particles projected in a pressurized fluid (dry air) or grinding with abra-

sive belts or wheels. In the latter case, the abrasive is either alumina (corundum), silicon carbide (carborundum) or zirconia (zirconium oxide). After sandblasting or grinding, the surface must be degreased with a solvent (1-1-1 trichloroethane) to eliminate all traces of abrasive residues.

Cleaning

Degreasing in hot alkali baths

These baths remove foreign material from the stainless steel surface. Agitation is recommended for increased efficiency. After degreasing, thorough rinsing with pure water is essential.

Solvent degreasing

The principal solvents used are trichloroethylene and 1-1-1 trichloroethane. The best results are obtained when they are used in

the vapor phase, since the liquid which condenses on the metal surface is always clean. If cleaning is carried out with a cloth, it must be white, and must be changed as soon as it becomes even slightly dirty. If cleaning is performed by immersion in liquid solvent, it is essential to verify the cleanness of the bath, which must contain little or no grease. After cleaning, all residues must be removed from the surface with a detergent, followed by abundant rinsing in pure water.

Chemical treatments

Acid bath pickling

Details of these treatments are given in the section “pickling baths” of Chapter 10. The most commonly employed compositions are mixtures of nitric and hydrofluoric acids.

Pickling followed by anodizing

After acid bath pickling, anodizing is performed in either nitric acid or a mixture of sulfuric and chromic acids.

Laboratory results obtained with different adhesives

Tensile-shear tests have been performed in the laboratory on a number of adhesively bonded joints, in the as-bonded condition. Only cases of “cohesive failure” were considered, i.e. failure within the adhesive itself, as opposed to “adhesive failure” at the metal/adhesive interface. All the tests involved the austenitic stainless steel X5CrNi18-10/1.4301, with a 2B surface finish, with roughness values R_a varying from 0.03 to 0.2 μm . In order to facilitate bonding of certain adhesives, an epoxy-modified acrylic bonding primer was used.

With a room temperature curing acrylic adhesive (minimum time 20 minutes), the shear strength measured for a 200 μm thick bond layer was about 13 N/mm^2 , whatever the surface preparation. For a room temperature curing polyurethane adhesive (minimum time 2 hours under applied pressure

or 48 hours without pressure), the shear strength measured for a 200 μm thick bond layer was 12 N/mm^2 with a bonding primer, although values of about 2 N/mm^2 were common with other adhesives of the same family. In the case of the epoxy-based adhesives, shear strengths of the order of 30 N/mm^2 are typical for 200 μm thick joints. However, the curing time necessary at ambient temperature varies from 48 hours to several days, but can be reduced to a few tens of minutes by increasing the temperature to between 100 and 170 $^\circ\text{C}$.

For mastics (polyurethanes and silicones), the shear strengths vary from 1 to 3 N/mm^2 , with curing times between 2 and 4 weeks at room temperature. These products can be used to produce bonds with thicknesses greater than 1 mm.

The design of adhesively bonded joints

- a) In order to produce an adhesively bonded joint which will give satisfactory service performance, it is essential to design it in such a way that it is loaded only in tensile shear, or in compression, and never in the peeling or cleavage mode. The risk of peeling at the extremities can be limited by appropriate seaming.
- b) The area of the adhesively bonded joint must be calculated to sufficiently spread out the load and reduce the stresses to acceptable levels. For “high performance” adhesives, the overlap can be limited to 15 to 30 times the thickness of each of the two metal substrates.

For other adhesives, this value must be raised to about 100 times. The following empirical formula gives the length of overlap l , in mm, as a function of the substrate thickness t , the substrate yield stress Y (N/mm^2) and the shear strength of the adhesive τ (N/mm^2), the latter parameter being determined from a tensile-shear test :

$$l = Y \times t / \tau$$

Thus, for 0.5 mm thick X5CrNi18-10/1.4301 stainless steel substrates ($Y = 320 \text{ N}/\text{mm}^2$) bonded with an adhesive with a shear strength of 20 N/mm^2 , $l = 320 \times 0.5 / 20 = 8 \text{ mm}$.

c) The thickness of the substrates and the bond layer must also be optimized in terms of mechanical strength in order to adapt the joint geometry to the service loads, avoiding the risk of cleavage effects. When the joint is subjected to dynamic loading, its strength must be about four times the dynamic stress

level. In the case of high strength adhesives, the thickness of the bond layer is typically of the order of 0.2 mm. In contrast, for certain flexible adhesives, particularly mastics, a thickness of 2 mm is common, and can often be a considerable advantage.

Example applications

Sandwich panels for curtain walling

These panels are generally composed of austenitic stainless steel facing sheets adhesively bonded to an aluminum alloy honeycomb structure. After assembly, the panels must have excellent flatness, and this is an advantage of adhesive bonding. The stainless steel sheet surfaces can be

prepared either by sandblasting or with an epoxy based primer. The adhesives employed are of the polyurethane-epoxy type and bonding is performed by either hot or cold pressing.

Wall coverings

The outstanding properties of stainless steels with regard to ease of cleaning and sterilization make them choice materials for clean rooms. It is quite simple to bond

austenitic stainless steel panels to a thoroughly cleaned plain carbon steel support structure, using an epoxy adhesive that cures at ambient temperature.

Decorative applications – monuments

In order to produce easy-to-clean floors, with good wear resistance and an attractive appearance, it is common practice to use *engraved* austenitic stainless steel sheet, often adhesively bonded either to wooden panels (plywood or fibreboard) or directly to a concrete slab. For this type of assembly loaded in compression, neoprene-based adhesives (i.e. elastomeric adhesives in a

solvent) can be employed, with the advantage that they can be applied and cured at room temperature.

When large monuments are built with stainless steel, generally the austenitic grade X5CrNi18-10/1.4301, two different construction techniques are employed. The first of these involves a self-supporting “skin”, generally assembled by weld-

ing, requiring pickling and passivation of the heat affected zones, followed by polishing of the whole surface to give it a uniform appearance. In the second procedure, the weight is supported by a framework of stainless steel tubes and shaped

sections, on top of which is placed a thin skin of similar grade. This skin used to be attached to the support by riveting, but nowadays it is adhesively bonded with a polyurethane adhesive that cures at ambient temperature.

Transport equipment

In this area, the most characteristic applications are :

- Railroad car doors, composed of two austenitic stainless steel panels whose inside faces are polished before application of a bonding polymer (epoxy). After positioning of the panels, a polyurethane foam is injected and bonding is accomplished by hot pressing.
- Bus and coach bodies. In order to increase the life and reduce weight,

coach manufacturers now use a framework of stainless steel shaped sections and tubes in either the ferritic alloy X2CrNi12/1.4003 or the austenitic grade X5CrNi18-10/1.4301. The skin, which is adhesively bonded to this framework, is composed of glass fiber reinforced polyester panels. The adhesive employed is generally of the polyurethane type, joining being performed by pressing at ambient temperature.

Medical applications

The major medical applications are :

- Hypodermic needles. The needle itself is produced from a fine austenitic stainless steel tube which is cold drawn and sized to obtain the required diameter. After cutting to length and bevelling at one end, the other end is bonded into the bore of a glass, polycarbonate or ethylene polymethacrylate component. The adhesive employed is a “medical” acrylic,

which can be cured at room temperature under ultraviolet radiation.

- Hip prostheses. The ball head is often made from vacuum remelted high molybdenum austenitic stainless steel. The implant is joined to the femur with a methyl methacrylate base cement. In direct contact with the biological fluids, both the stainless steel and the adhesive are well tolerated by the organism.

3.4 Mechanical joining

Introduction

The joining processes other than welding, brazing, soldering and adhesive bonding applicable to carbon steels can be readily transposed to stainless steel sheet. However, it is essential to ensure that none of the surfaces in contact are liable to induce corrosion due to galvanic coupling. In order to prevent this possibility, the differ-

ent parts to be assembled should preferably be made from the same stainless steel, or at least from equivalent grades.

Screwing and bolting

Stainless steel screws and bolts are produced in all the principal grades. The 13% Cr martensitic alloys are used when high strength is required. The 17% Cr ferritic steels must be used only for mild aggressive environments. Their corrosion resistance in chloride containing media can be enhanced by the addition of 1 to 1.5% of molybdenum. Austenitic grades (Fe-Cr-Ni alloys), and particularly those containing molybdenum, enable the majority of corrosion problems to be solved.

Screws and bolts are produced by three processes, namely machining, cold forging-extrusion, and hot stamping (die forging). In the former case, free machining grades are often employed to improve the productivity. The range of fastener components produced in stainless steels is the same as for plain carbon steels. The majority of them are hexagonal headed bolts, slotted and cross-recessed screws, self-tapping sheet screws, stud bolts, hexagonal nuts and washers. Stainless steel screws and bolts are normally delivered after passivation to ensure good corrosion resistance. Those produced from certain grades by cold forming enable high mechanical strengths to be obtained.

Riveting

Riveting is almost always carried out at ambient temperature, using rivets whose maxi-



mum diameter is about 5 mm. The principal stainless steel rivets are of the solid round head type, bored rivets, and blind rivets, for use when one of the two sides of the sheet is

not accessible. It is strongly recommended to design joints in such a way that the rivets are loaded in shear rather than in tension.

Clinching

Clinching is a fairly recent joining technique, which in certain cases can be a useful substitute for riveting or spot welding (fig. 3.4.1). It can be readily applied to stainless steels due to their high ductility. Since it is a cold forming process, it causes no structural modifications or surface oxidation. Like in riveting, the sheets to be joined must overlap, and this can cause the formation of a confined space capable of initiating crevice corrosion. In order to avoid this risk, clinching is usually combined with adhesive bonding, producing a hermetically sealed joint. Moreover, the presence of the adhesive gives the joint a certain vibration damping capacity.

In practice, clinching is performed either with portable hydraulic tools or with hydraulic presses, comprising a punch and either a fixed die or a mobile (articulated) die. With a fixed die, the local clinched joint is round,

whereas it may be either round or rectangular with a mobile die.

Numerous stainless steel assemblies have been produced by clinching, mostly X6CrTi12/1.4512 automobile exhaust system components, with sheet thicknesses up to 1.5 mm, together with parts made from 1 mm thick sheet in X6Cr17/1.4016 and X5CrNi18-10/1.4301 grades. For a given sheet thickness, if the punch force required for plain carbon steel is F , then it will be $1.5 \times F$ for X6Cr17/1.4016 ferritic stainless steel and $2 \times F$ for the X5CrNi18-10/1.4301 austenitic alloy.

Fig. 3.4.1 - Principle of clinching

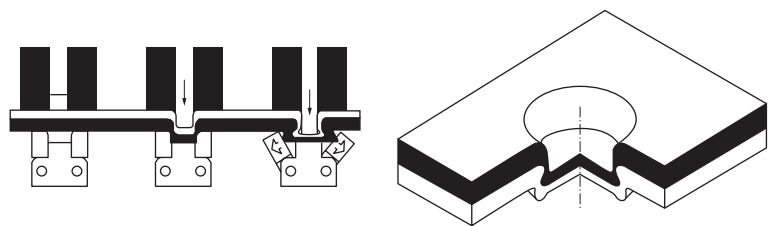

Lockseaming

Lockseaming is a mechanical sheet joining technique in which the edges of one or both of the sheets concerned are bent through an angle of 180° to produce a tight seam. The operation involves folding, or more frequently, rolling with a series of appropriate tools (fig. 3.4.2). Like in clinching, it is possible to join different materials. For example, a deep drawn X5CrNi18-10/1.4301 aus-

Fig. 3.4.2 - Joining by lockseaming

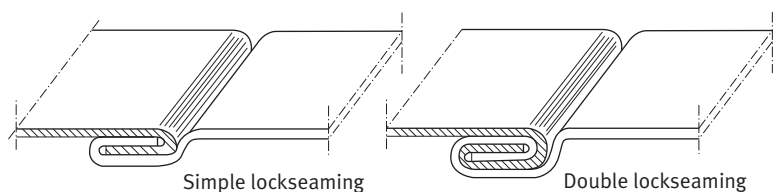

tenitic stainless steel appliance component could be joined to a relatively undeformed X6Cr17/1.4016 ferritic part whose corrosion resistance in the intended service medium is sufficient. This can allow significant cost savings if it is envisaged right from the product design stage.

Contrary to a commonly held belief, lock-seaming of stainless steels enables the pro-

duction of perfectly leaktight joints. In the event of doubt, sealing can be enhanced by the use of a seam of adhesive. Because of the rapidity of implementation and the economies it can generate, lockseaming is widely used in the manufacture of domestic appliances when the mechanical loads involved are not too high.

Tube expansion

Tube expansion is used to rigidly and hermetically fix the end of heat exchanger tubes in the holes of the tubeplate (fig. 3.4.3). The expanding tool is composed of a conical shaft supporting a ring of rollers. The rotating shaft is pushed into the end of the tube, causing it to expand outwards. The drive torque increases with the degree of expansion, and tends towards a limit which enables the as-expanded tube thickness to be controlled via a torque limiter. The initial clearance between the outside diameter of the tube and the diameter of the tubesheet bore varies from 0.2 mm for small tubes to 0.4 mm for tubes with diameters greater than 30 mm.

Three major joint configurations are employed:

- Tube expansion in a smooth bore, which enables tube replacement.
- Tube expansion in a grooved bore, which prevents tube replacement.
- Tube expansion in a smooth bore, with flaring of the tube end.

In certain cases, the tube expansion operation is completed by welding, with a circular seam made by the orbital TIG process. However, such practice is not without risk and is generally not recommended. Joints produced by tube expansion without welding are usually perfectly leaktight up to internal pressures of the order of 50 bars and maximum temperatures of about 150 °C.

Fig. 3.4.3 - Joining by tube expansion (all lengths in mm)

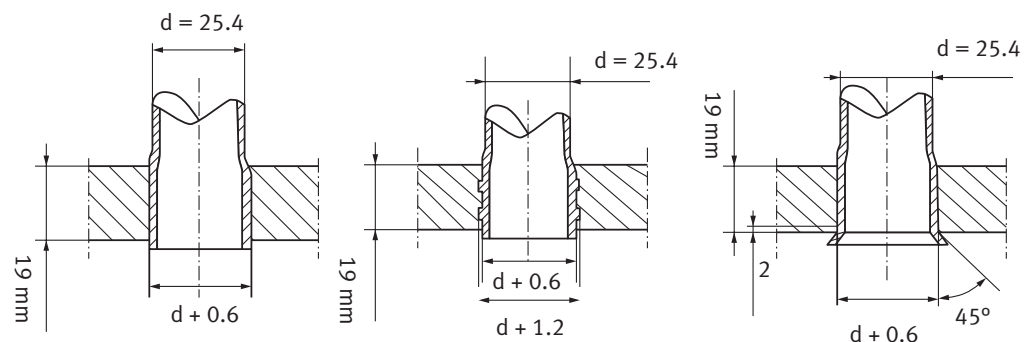

4. Surface condition

4.1 Characterisation of the surface

Introduction

As indicated in Chapter 5, a wide range of surface conditions are available for designers to choose as a function of the intended application. This great diversity essentially concerns flat products, i.e. sheet and strip, for which surface quality is often an important aspect. The surface appearance, and especially its stability with time, are determined by the corrosion resistance. The various industrially available surface conditions are obtained in three different ways:

- a) By on-line treatments, for example, in the case of the “annealed and pickled” and “bright annealed” conditions.
- b) By mechanical engraving in a rolling operation (also on-line), involving the transfer to the stainless steel strip of a pattern or texture from one or two rolls.
- c) By the removal of matter with abrasive belts or wheels. This type of treatment can be applied both to coiled strip and to individual sheets.



Photo 11: Milk pasteurizing plant

Characterization of surface condition

Although surface appearance is partly subjective in nature, in order to characterize it and reproduce it industrially, it is necessary to employ “objective” techniques.

Among these, those most frequently used are roughness and reflectivity measurements.

Roughness

Roughness measuring instruments enable the microgeometry of the surface to be recorded in two or three dimensions. The recorded profile (fig. 4.1.1) is used to calculate the average roughness R_a and the maximum roughness R_t . R_a is the arithmetic mean of all the deviations of the profile from the mean line l_m . The maximum roughness R_t is the largest peak-

to-valley height measured in the complete assessment length (i.e. the vertical distance between the lowest and highest points).

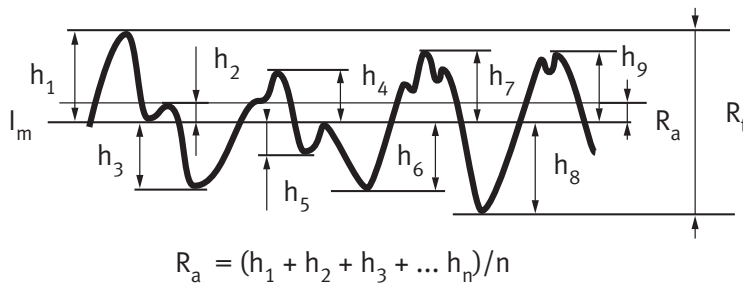

Fig. 4.1.1 - Definitions of the average roughness R_a and the maximum roughness R_t

Brightness

Brightness is evaluated by measuring the intensity of a light beam reflected by the surface to be analyzed, as a function of the intensity and angle of the incident beam (fig. 4.1.2). By way of example, Table 4.1.1 gives typical brightness values for two common surface conditions for a ferritic and an austenitic stainless steel.

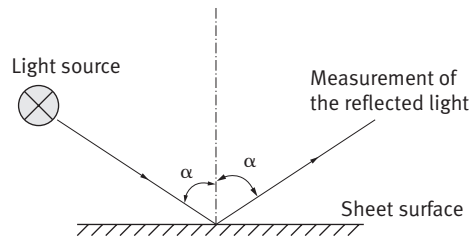

Fig. 4.1.2 - Brightness measurement

European designation EN 10088-2		Brightness (dimensionless units)	
Name	Number	2B (annealed, pickled, skinpassed)	2R (bright annealed, skinpassed)
Austenitic			
X5CrNi18-10	1.4301	20 – 30	50 – 55
Ferritic			
X6Cr17	1.4016	50 – 55	56 – 60

Table 4.1.1 - Typical brightness values for stainless steels with common surface conditions

The principal surface conditions

The diversity of the available surface conditions is represented in Table 4.1.2, which should be analyzed in combination with Table 1.5.1 (Section 1.5), describing the manufacturing process for stainless steel flat products. The starting product is the hot rolled strip produced either in a continuous mill or a reversible Steckel mill. This strip is annealed, shot blasted and pickled to obtain what is usually considered as the hot rolled product (HR), corresponding to no. 1 finish, designated 1D, according to EN 10088-2. The HR product with its 1D finish is then subjected to a series of cold rolling operations on Sendzimir mills, generally with one or more annealing treatments. Three types of finish are distinguished for the resulting cold rolled products (CR):

- 2D finish : CR + annealed + pickled;
- 2B finish : CR + annealed + pickled + skinpassed;
- 2R finish : CR + bright annealed (in a reducing atmosphere, followed by a skin pass).

The skin pass involves rolling in a two-high mill to produce a slight elongation. Since the rolls have a mirror finish, skin pass rolling improves both the flatness and the brightness.

The strip products obtained in this way are often subsequently polished with an abrasive of appropriate grain size, in order to obtain the required surface appearance (generally either matt or bright), whose evaluation by visual examination is relatively subjective. Abrasive belt polishing is well

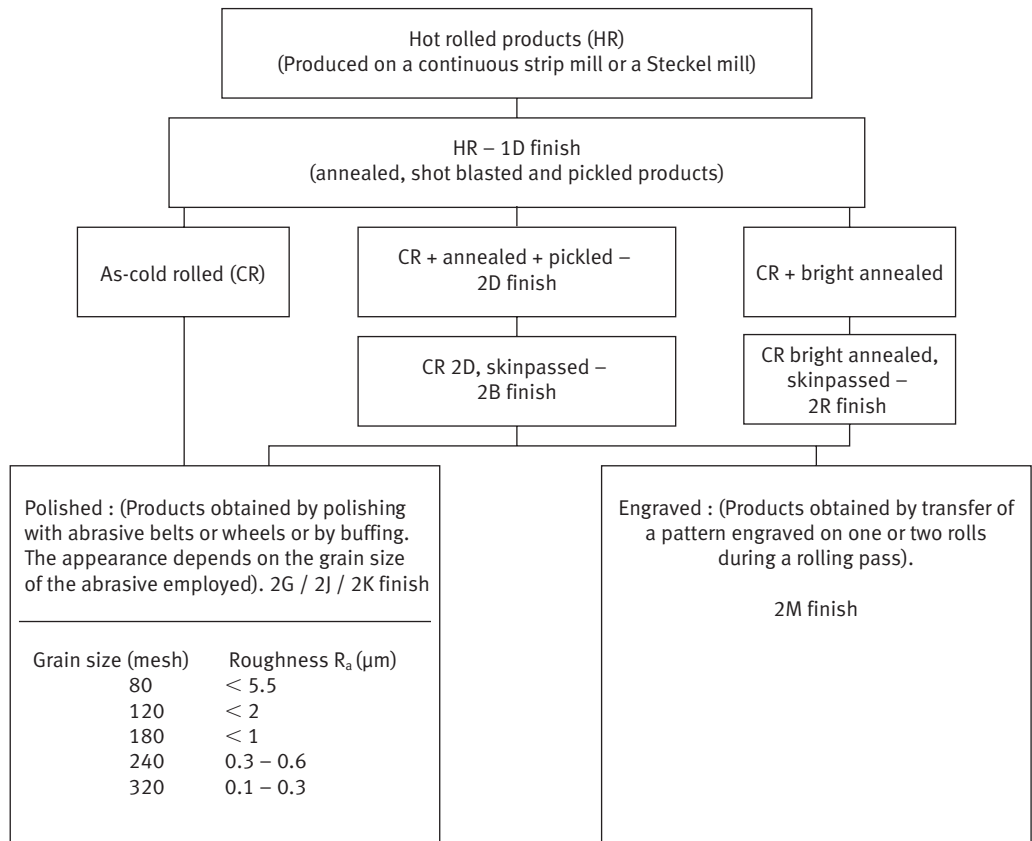

Table 4.1.2 - Principal surface finishes for stainless steel flat products

adapted to flat surfaces. In order to obtain a satin finish, brushes with natural or synthetic fiber bristles are used. Polishing with abrasive strips bonded to a wheel produces short scratches and facilitates retouching. Finally, mirror finishes are obtained by polishing with a buffing wheel, composed of a number of bonded felt disks, typically 200 to 300 mm in diameter, with tangential speeds of the order of 2000 m/min.

In addition to mechanical polishing with abrasive belts and wheels, stainless steels can be polished electrolytically.

Electropolishing is particularly suited to parts whose shape makes them impossible to polish by mechanical means. The workpiece is immersed in a bath of electrolyte and acts as the anode. The electrolyte composition can vary, depending on the process configuration, with three main types, namely phosphoric acid solutions, citric acid-sulfuric acid mixtures and glycolic acid-sulfuric acid mixtures. Depending on the type of bath, the current density varies from 8 to 65 A/dm², the voltage from 2 to 12 V and the temperature from 60 to 90 °C.

4.2 Surface preparation and treatments

Peening

Like other blasting operations, peening consists in projecting a high velocity stream of hard particles, with diameters from 0.15 to 0.6 mm, through a nozzle onto the workpiece surface. The particles employed are more or less spherical and non-abrasive. Their velocity and the duration of the operation must be optimized to obtain the desired result. A larger particle size and a higher velocity increase the roughness, whereas the latter tends to decrease with time as the operation is continued.

Peening induces a heavily cold worked surface layer, whose thickness can attain 0.3 mm. The associated compressive stresses can have a beneficial influence on fatigue strength, and peening thus provides a means of increasing the service life of finished components.

If peening cannot be followed by a decontamination treatment, the use of non-stainless iron-rich particles must be avoided. Finally, peening often constitutes an effective surface preparation before painting.



Photo 12: Surface finishing. A variety of different finishes – such as mirror polish – can be achieved to meet technical requirements

Sand blasting and glass bead peening

In sand blasting, abrasive particles (silica, alumina, etc.) are projected onto the workpiece with the aid of a high pressure fluid (air or water). Glass bead peening is a simi-

lar operation in which the particles are small non-abrasive glass beads, and is particularly useful for obtaining a uniform appearance on complex shaped finished parts.

Wheel grinding

In this process, the workpiece surface is abraded with a grinding wheel rotating at a high speed, with typical tangential velocities between 20 and 80 m/sec. The abra-

sive particles are generally either alumina (corundum) or silicon carbide (carborundum), and more rarely boron carbide or diamond. For rough grinding operations,

such as the removal of the excess thickness at a weld, 100-200 mm diameter cylindrical wheels are employed, with grain sizes of the order of 40 mesh. Depending on the type of binder, the tangential velocity varies from 25 to 60 m/sec. For finish grinding

operations (e.g. fine levelling of welds), semi-rigid or flexible abrasive disks are used, with diameters in the range 150-250 mm and grain sizes from 80 to 320 mesh, the tangential velocity being between 12 and 15 m/sec.

Polishing¹⁾

Polishing is the most common surface finishing operation and has already been described in the section about the principal surface conditions and Table 4.1.2. When applied to a finished part, the aim is often to restore the original appearance of a particular region, such as a weld. In other cases, for example cooking utensils or dishes, the purpose may be to give the finished article a matt or bright appearance which cannot be obtained directly after a drawing or other forming operation. In all cases, the tools employed must be strictly reserved for stainless steels, in order

to avoid all risk of contamination by iron particles.

Compared to other materials, for stainless steels, the removal of matter requires a greater amount of energy. Care must therefore be taken to avoid excessive heating, which can cause slight surface oxidation, hindering the formation of a passive film. The pressure exerted by the disk or belt must be adjusted to the minimum level allowing satisfactory abrasion without local overheating.

Chemical treatments²⁾

Prepickling or scale conditioning

After certain high temperature operations in oxidizing atmospheres, the scale is too thick and too dense to be removed by normal acid pickling. In these conditions, three types of prepickling treatment can be applied:

- Immersion for about 15 minutes in a bath of molten caustic soda containing 5 to 20% of sodium or potassium nitrate at 450 °C.

- Immersion for about 15 minutes in a molten mixture comprising 85% of caustic soda, 14% of sodium or potassium nitrate and 1% of sodium chloride at 485 °C.
- Immersion for a few minutes in a molten mixture of caustic soda and 1 to 2% of sodium hydride at 380 °C.

Whatever the treatment employed, it must be followed by immersion and rinsing in cold water, then by acid pickling.

¹⁾ This subject is treated in greater detail in following Euro Inox publication: VAN HECKE, Benoît, *The Mechanical Finishing of Decorative Stainless Steel Surfaces* (Materials and Applications Series, Volume 6), Luxembourg: Euro Inox, 2005

²⁾ This subject is treated in greater detail in following Euro Inox publication: CROOKES, Roger, *Pickling and Passivating Stainless Steel* (Materials and Applications Series, Volume 4), Luxembourg: Euro Inox, 2004

Acid bath pickling

Acid bath pickling removes the oxide scale formed during high temperature operations in an oxidizing atmosphere, including welding. Pickling can be performed in several ways, but whenever possible, immersion in an acid bath is to be preferred.

For ferritic and martensitic stainless steels, the reagents employed are either mixtures of nitric and hydrofluoric acids or sulfuric acid. The typical compositions and treatment conditions are given below.

a) Nitric-hydrofluoric acid baths

- 62% nitric acid (40° Baumé) : 200 liters
- 65% hydrofluoric acid : 10 liters
or sodium fluoride : 15 kg
- Water : 800 liters
- Temperature : 50–60 °C
- Duration : about
15 minutes

b) Sulfuric acid baths

- 90% sulfuric acid : 100 liters
- 35% hydrochloric acid : 50 liters
- Water : 900 liters
- Temperature : 50–55 °C
- Duration : about
15 minutes

For *austenitic stainless steels*, either nitric-hydrofluoric or sulfuric acid baths are also used, but with different compositions.

a) Nitric-hydrofluoric acid baths

- 62% nitric acid (40° Baumé) : 200 liters
- 65% hydrofluoric acid : 20 liters
or sodium fluoride : 30 kg
- Water : 800 liters
- Temperature : 50–60 °C
- Duration : about
15 minutes

b) Sulfuric acid baths

- 90% sulfuric acid : 100 liters
- Water : 900 liters
- Temperature : 60 °C
- Duration : a few
minutes

Passivation

When exposed in air, stainless steels passivate naturally, but the time required can vary greatly, depending on the type of atmosphere. In order to ensure that the passive layer reforms rapidly after pickling, a passivation treatment is therefore per-

formed in acid baths, in the following conditions.

For ferritic and martensitic stainless steels:

- 62% nitric acid (40° Baumé) : 500 liters
- Water : 500 liters
- Temperature : about 20 °C
- Duration : about 30 minutes

For austenitic stainless steels:

- 62% nitric acid (40° Baumé) : 250 liters
- Water : 750 liters
- Temperature : about 50 °C
- Duration : about 15 minutes

Decontamination

The decontamination treatment is similar to that used for passivation, but its purpose is different. During the various processing operations, the surface of stainless steel parts

can become contaminated by readily oxidizing iron-rich particles, whose presence can create initiation sites for corrosion. It is therefore essential to remove them, and this is the aim of the decontamination treatment.

Finishing treatments for welds

The finishing treatments used for welds (p. 89) are virtually identical to those

described above, and are absolutely essential to give the welds a similar corrosion resistance to that of the base metal.

Surface maintenance*

Stainless steels are used essentially for their good corrosion resistance, which is synonymous with long life and durability

of appearance. Nevertheless, it is essential to clean their surfaces periodically, in order to remove dirt.

Cleaning reagents

General purpose products

Most everyday cleaning products can be used for stainless steels. However, since their exact composition is generally not known, after cleaning, it is essential to abundantly rinse the surface with pure water.

riodic cleaning. Whatever the product employed, cleaning must be followed by abundant rinsing in pure water.

Detergents and soaps

Most domestic detergents and soaps can be used. In particular, window washing products are generally well adapted for pe-

Abrasive powders and pads

These products can be useful for rubbing off very adherent dirt. However, they generally modify the brightness and hence the appearance of the surface. For this reason, milder scouring creams are to be preferred. In all

* This subject is treated in greater detail in following Euro Inox publication: *Cleaning and Maintenance of Stainless Steel Architectural Surfaces*, Luxembourg: Euro Inox, 2003

cases, the powders used must be free from iron oxides. Cleaning must always be followed by abundant rinsing with pure water. In the case of polished surfaces, rubbing must be carried out parallel to the polishing scratches.

Solvents

The use of solvents is sometimes necessary to remove highly resistant deposits. All the common solvents can generally be used, but residues should be removed by abundant rinsing in pure water.

Acid-based cleaning reagents

The use of acid-based cleaning products should be envisaged only in very specific cases (e.g. scale or fur removal), according to a well established procedure. Certain products based on phosphoric or nitric acids are specially designed for stainless steels. Conversely, products containing hydrochloric acid are strictly prohibited. All traces of acid must be eliminated by abundant rinsing in pure water.

Alkali-based cleaning reagents

Sodium and potassium hydroxide solutions are generally well adapted to stainless

steels. However, their use must be followed by abundant rinsing in pure water.

Disinfectants

Cold diluted hypochlorite can be used with great precaution. However, hot hypochlorite, even highly diluted, is strictly prohibited. Contact times between the metal and the solution must be limited to the absolute minimum. Even more so than with other products, disinfection must be followed by thorough rinsing in pure water.

Protective waxes

The best protection for a stainless steel is its passive layer. These products provide no extra protection in terms of corrosion resistance, and can often even be detrimental, since they can help to trap dirt.

Compatibility with stainless steels

All cleaning products are not identical with regard to their compatibility with stainless steels. Users must therefore check with the product suppliers whether the particular product is suitable for cleaning the type of stainless steel envisaged.

Cleaning methods

Building and decorative applications

There are three different types of cleaning operations, corresponding to commissioning, routine maintenance and renovation.

Cleaning on commissioning

During storage and handling on the construction site, stainless steel products are

generally protected with a peelable adhesive plastic film, which is removed when the building is commissioned. If the surface is exposed to sunlight, the duration of exposure of this film must not exceed 6 months. Once the film has been removed, care must be taken to keep the surfaces clean,

particularly if work continues on the site. In the event of accidental soiling, cleaning must be performed with an appropriate detergent, followed by abundant rinsing with pure water.

Routine maintenance cleaning

- *Outdoor surfaces:* Maintenance cleaning is usually performed with standard chlorine-free detergents, in the form of powders, liquids or soaps. Washing should be carried out with a sponge and followed by abundant rinsing with pure water. It is recommended to wipe off the surplus liquid with a squeegee to prevent moiré effects on drying.
- *Indoor surfaces:* Routine cleaning can be carried out with the same detergents as for outdoor surfaces. However, this is not sufficient to remove fingermarks, which

require acid-containing products with the addition of a degreasing agent. For very resistant stains, it may be necessary to use abrasive scouring pads, made from stainless steel wool, nylon, or similar materials. Rubbing must be performed in the direction of initial polishing. The use of ordinary steel wool is strictly prohibited. Great care must also be taken to avoid splashing with chlorine-containing detergents used for cleaning floors (e.g. hypochlorite solutions and other disinfectants). Should this occur, the affected surfaces must be immediately rinsed abundantly with pure water.

Cleaning for renovation

If routine cleaning has been long neglected, or if the stainless steel shows traces of corrosion, a specific treatment is necessary after having made a precise diagnosis.

Food processing equipment

Cleaning must be adapted to the type of product in contact with the stainless steel equipment. It is almost always followed by a disinfection treatment, and then by abundant rinsing with pure water. Certain disinfectants are aggressive towards stainless steels, so that strict procedures must be applied. The latter must be approved by the supplier, who must guarantee the compat-

ibility of his product with the type of stainless steel concerned. If incipient corrosion is observed, the manufacturer of the cleaning product or disinfectant must be immediately consulted, together with the stainless steel supplier, in order to carry out an appropriate treatment according to their recommendations.

Collective catering equipment and domestic appliances

Collective catering equipment and domestic appliances are usually cleaned on a daily basis. When properly performed, such cleaning is a warranty of long life for the stainless steel. The products used are those described

in the section “cleaning reagents”, while the precautions to be taken are those indicated in the section “cleaning methods”.

5. Testing and inspection

5.1 Metallurgical testing and inspection

Introduction

Only metallurgical and mechanical testing and inspection will be considered in the present part, since the dimensional inspection techniques employed for stainless steels are not basically different to those used for plain carbon steels.

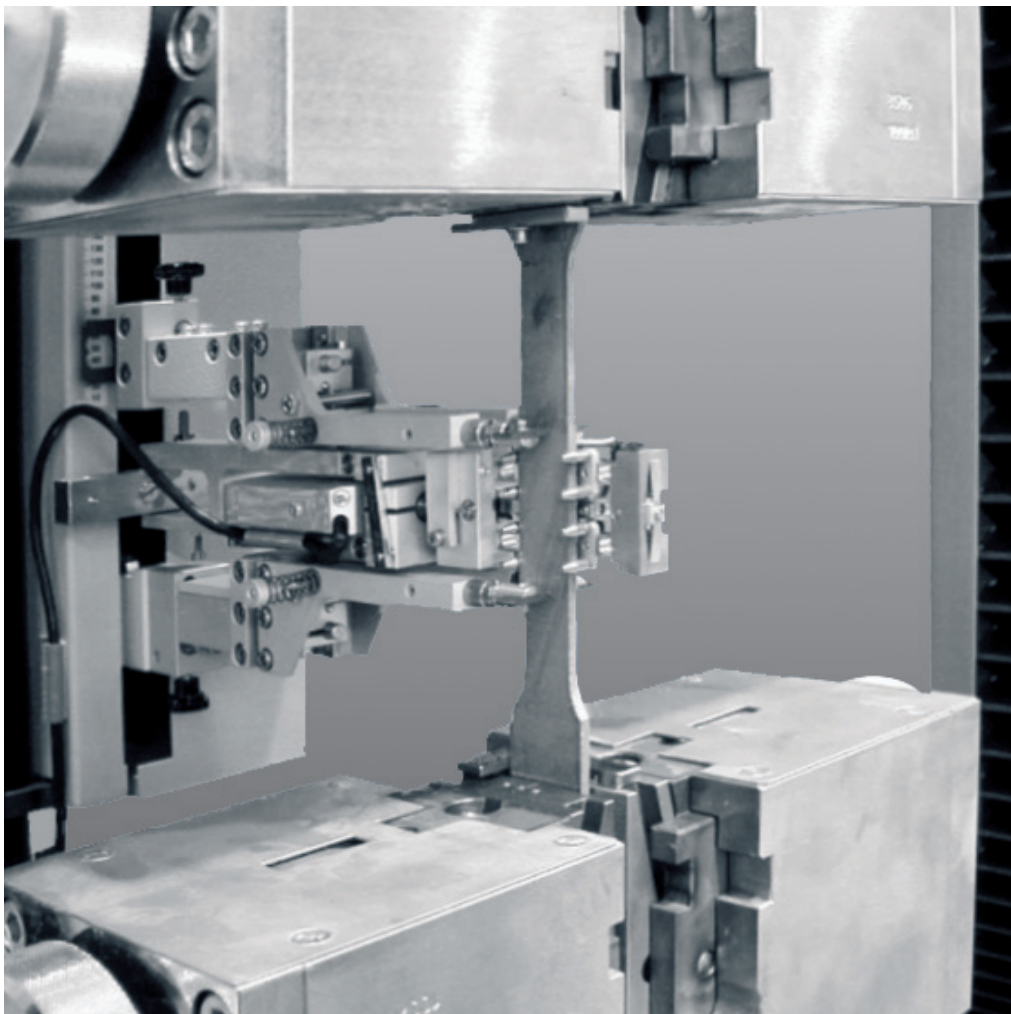

*Photo 13:
Tensile-testing:
In tension test, a specimen is deformed by constant but smooth load until it breaks. During the test, the stress to produce given elongation (or strain) is measured as dependent variable, and based on the measured values a stress-elongation (or strain) curve is plotted.*

Metallurgical testing and inspection

In order to characterize an alloy in metallurgical terms, it is necessary to determine its chemical composition and its microstruc-

ture, and this is the purpose of metallurgical testing and inspection.

Chemical analysis

Although the term “chemical analysis” is widely employed to indicate the determination of the elemental composition or “chemistry” of an alloy, in fact, increasing use is made today of physical techniques, such as X-ray fluorescence spectrometry, glow discharge optical spectrometry, opti-

cal emission spectrometry, etc., particularly for the major alloying elements (Cr, Ni, Mn, Si, etc.). For certain elements, such as carbon, sulfur and nitrogen, specific methods are employed, involving the analysis of the combustion products based on their effects on the absorption of infrared radiation.

Metallographic examination

A distinction is generally made between macrographic examination at low magnifications (up to $\times 50$) and micrographic examinations at higher magnifications ($\times 100$

to $\times 1200$). The etching reagents used to reveal the micro-structure are adapted to each family of stainless steels.

Austenitic stainless steels

In order to reveal the general microstructure, Vilella’s reagent is employed. This is a mixture of aqua regia and glycerine, with the approximate composition: 2 volumes of

hydrochloric acid, 1 volume of nitric acid and 3 volumes of glycerine. The immersion time is of the order of 30 seconds.

Ferritic stainless steels

One of the most frequently used etchants is Vilella's reagent, whose composition is: 5 ml of hydrochloric acid, 1 g of picric acid and 95 ml of ethyl alcohol. There is also a modified version particularly adapted

to 12% Cr grades, whose composition is 20 ml of hydrochloric acid, 12 ml of acetic acid, 1 g of picric acid and 68 ml of ethyl alcohol.

Duplex austenitic – ferritic stainless steels

One of the most commonly employed techniques for revealing the micro-structure of duplex austenitic – ferritic stainless steels is electrolytic etching for 10 to 30 seconds

in an 85% volume nitric acid-15% volume water solution, with the specimen as the anode and the voltage adjusted to give a current density of 50 mA/cm².

5.2 Mechanical testing



Photo 14: Steam pressure cooker

Introduction

Like for other metals and metallic alloys, the mechanical characteristics are determined by the elasticity, plasticity and toughness properties. Elasticity is the faculty of a material to deform reversibly when subjected to a stress and to return to the initial state when the stress is removed. Plasticity or ductility is the aptitude to undergo permanent deformation under load without fracture. This property is frequently exploited, for example in forming operations such as bending and drawing. Toughness is a measure of the energy necessary for fracture and implicitly involves the tendencies for either brittle cleavage or ductile tearing, together with the transition temperature at which the fracture mode changes from one to the other. It is usually determined in an impact bending

test on a notched specimen, by measuring the energy necessary for fracture at a given temperature.

The machines used for the mechanical testing of stainless steels are identical to those employed for ordinary steels and other metals and alloys.

Tension tests

Description of the test

In a tension test, a calibrated specimen is forced to elongate, generally at a constant imposed rate, requiring an increasing load, due to the reaction of the material. The test piece comprises two markers, separated by an initial distance l_0 (often 80 mm). If a force F is applied to the calibrated gage length of initial area A_0 , the resulting elongation increases the distance between the markers from l_0 to l . The corresponding nominal or engineering strain, expressed in %, is then given

by $e = 100(l - l_0)/l_0$, while the nominal or engineering stress is F/A_0 , and is expressed in N/mm² or MPa. The plot of F/A_0 as a function of e is called the nominal or engineering stress-strain curve, and comprises three distinct zones (fig. 5.2.1).

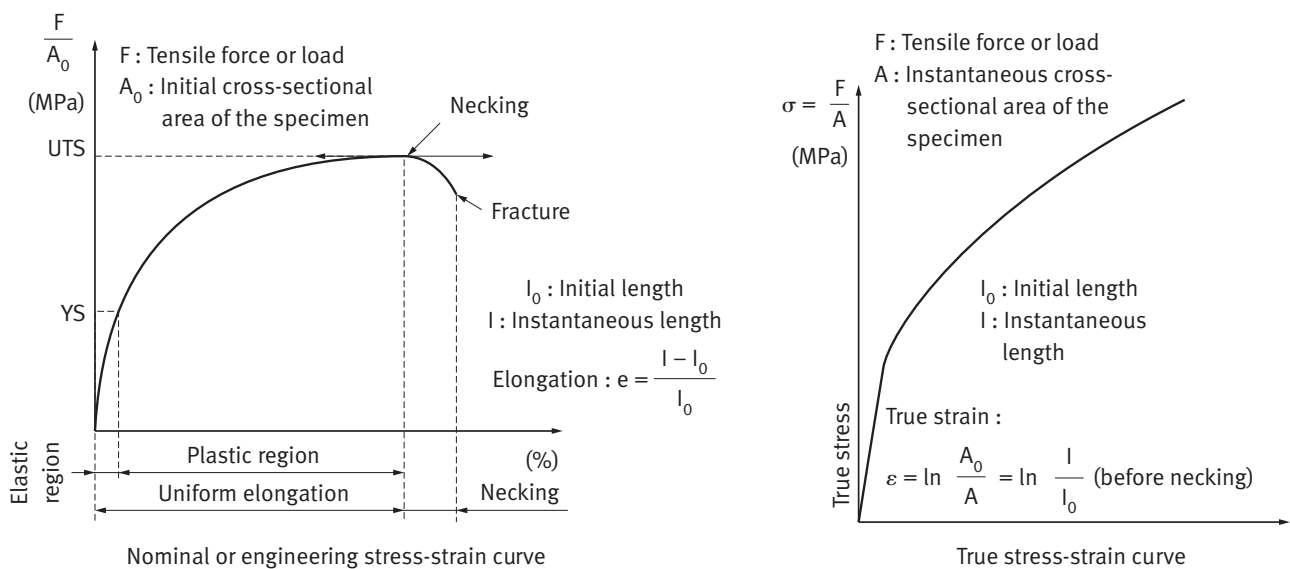

Fig. 5.2.1 - Stress-strain curves.

- a) The elastic region, in which the elongation e is proportional to the applied stress F/A_0 . Theoretically, when the stress is removed, the elongation disappears completely. The upper limit of this linear elastic region is called the yield point, with a corresponding yield stress or yield strength, YS . Since it is not always easy to determine, it is often measured at a finite amount of plastic strain, e.g. 0.2%, and is known as the “proof stress” (in this case the 0.2% proof stress, designated 0.2% PS or 0.2% YS). It is measured in N/mm^2 (MPa).
- b) The uniform plastic strain region, in which the metal continues to deform uniformly, but the stress rises less rapidly with strain and no longer in a linear manner. Furthermore, when the stress is removed, the specimen no longer returns to its initial length, but remains permanently deformed. This region occurs between the yield stress YS and the maximum stress, known as the ultimate tensile stress or strength, UTS , which is also expressed in N/mm^2 (MPa).
- c) Beyond the UTS , the deformation becomes locally concentrated, leading to a

constriction or “neck”, so that the stress determined in terms of the initial area falls until the specimen finally fails.

The values determined from the engineering stress-strain curve described above are those which are used in the majority of standards and specifications. However, a more correct way to analyze the results of a tension test is to employ the true stress and true strain. The true stress σ is the applied load at any moment divided by the instantaneous area A , i.e. $\sigma = F/A$. The true strain ϵ is obtained by integrating the nominal strain increments dl from l_0 to l , and is given by $\epsilon = \ln(A_0/A)$ ($= \ln(l/l_0)$ before necking). It is related to the nominal or engineering strain e by $\epsilon = \ln(1+e)$. The plot of σ against ϵ is the true stress-strain curve (fig. 5.2.2), which can be used to determine the strain hardening exponent n .

Figure 5.2.2 compares the engineering and true stress-strain curves for the austenitic stainless steel X5CrNi18-10/1.4301, often used for deep drawing applications. After the onset of necking, the true stress plotted is that at the neck root, which continues to rise up to fracture.

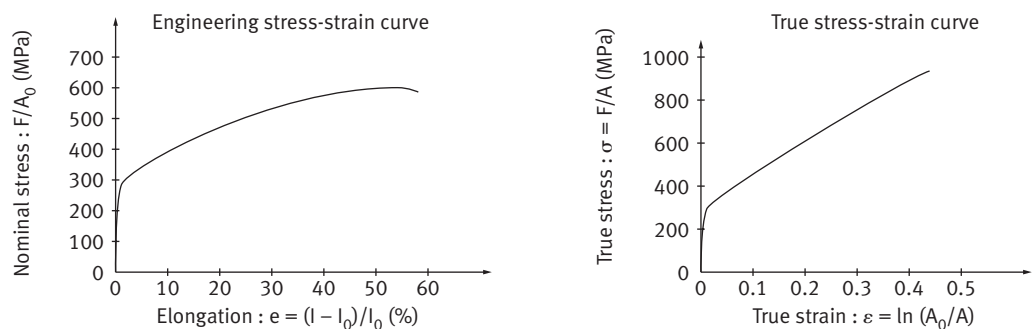

Fig. 5.2.2 - Engineering and true tensile stress-strain curves for X5CrNi18-10 austenitic stainless steel

Characteristic values for stainless steels

The different families of stainless steels (martensitic, ferritic, austenitic, duplex) show characteristic behaviours in tension tests, the differences being directly related to their corresponding microstructures.

Martensitic stainless steels in the quenched and tempered condition have very high *YS* and *UTS* levels, with correspondingly low elongations to failure *El* (%). In the as-quenched condition, the *YS* and *UTS* levels are even higher and the elongation lower. However, it is generally recognized that the tensile properties have little practical meaning in the as-quenched condition, which is better characterized by the microstructure and hardness.

Ferritic stainless steels have stress-strain curves fairly similar to those of plain carbon grades. In particular, they have a marked yield point drop, beyond which the load rises again. The corresponding upper and lower yield points are clearly visible on the recorded load-elongation curve. The *UTS* is typically about 550 N/mm², and is associated with elongations to failure of the order of 30%.

Austenitic stainless steels have stress-strain curves similar to that shown schematically in figure 5.2.2. Contrary to the ferritic

grades, the yield point is not clearly visible, and for this reason it is usual to measure the 0.2% proof stress, as described above. The *UTS* is generally of the order of 600 N/mm², while the elongation to failure can exceed 60%. This feature, associated with a high strain hardening rate (directly related to the strain hardening exponent *n*), makes these materials particularly suited for deep drawing. Furthermore, their capacity for energy absorption is among the highest of common materials.

Duplex austenitic - ferritic stainless steels have high *YS* and *UTS* values, due to their fine two phase structures (50% ferrite and 50% austenite), while their elongations to failure are intermediate between those of austenitic and ferritic grades. Typical values are 800 N/mm² for the *UTS* and about 35% for the elongation.

Table 5.2.1 summarizes the typical mechanical properties of the different stainless steels in various conditions.

Alloy type	<i>UTS</i> (N/mm ²)	0,2% <i>YS</i> (N/mm ²)	<i>El</i> (%)
Martensitic (1)	500 – 850	270 – 500	14 – 30
Martensitic (2)	1200 – 2000	1000 – 1600	2 – 10
Ferritic (3)	400 – 550	250 – 380	20 – 35
Austenitic (4)	570 – 730	215 – 360	40 – 65
Duplex (4) austenitic-ferritic	800 – 900	620 – 750	25 – 35

Table 5.2.1 - Typical mechanical properties of the different stainless steels in various conditions

- (1) Tempered,
- (2) As-quenched,
- (3) Annealed,
- (4) Solution annealed and rapidly cooled.

Hardness tests

Test types

Hardness testing consists in pressing an indenter into the flat specimen surface under a perfectly controlled load, then measuring the dimensions of the resulting in-

Fig. 5.2.3 - Principle of Rockwell hardness tests

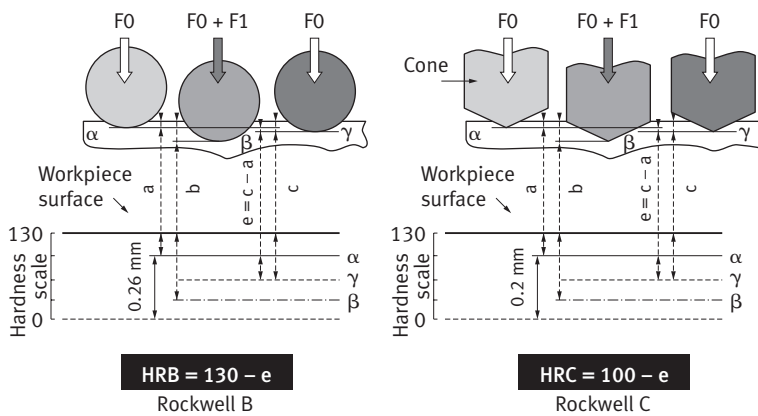

A minor load F_0 is first of all applied, to break through roughness and eliminate backlash, then a major load F_1 is applied, then removed. The difference in penetration depth e after removal of F_1 gives the hardness. Note that one hardness unit corresponds to 0.002 mm. Here, a , b , c , and e are expressed in hardness units, and α , β and γ in mm.

Fig. 5.2.4 - The Vickers hardness test

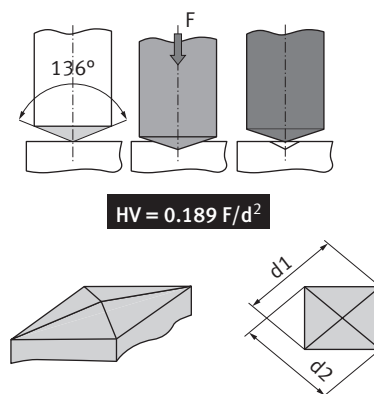

Indenter apex angle = 136°
 F = Test load in newtons to $\pm 1\%$
 d = Indentation diagonal in mm = $(d_1 + d_2)/2$

dentation. Various types of indenter are used in the different hardness tests. Thus, the Brinell and Rockwell B tests use a ball indenter, while the Rockwell C and Vickers tests use a pointed conical indenter. The three methods most commonly used for stainless steels are the Rockwell B, Rockwell C and Vickers tests, the corresponding hardness numbers being designated by HRB, HRC and HV respectively.

In the Rockwell B test (fig. 5.2.3), a 1/16 inch (1.59 mm) diameter steel ball is pressed into the workpiece under a load of 100 kg and the depth of the indentation is measured. The Rockwell B scale is limited to 100 HRB, beyond which the Rockwell C test is employed.

The Rockwell C test (fig. 5.2.3) is performed on the same equipment as the Rockwell B test, but with a conical diamond indenter, under a load of 150 kg, again with measurement of the depth of indentation.

The Vickers test (fig. 5.2.4) uses a diamond indenter with a square-based pyramid shape. The load can be chosen between 5 and 100 kg, a value of 5 kg being usually employed for stainless steel sheets. The hardness is determined by measuring the two diagonals of the indentation.

Characteristic hardness values for stainless steels

Table 5.2.2 gives characteristic hardness values for the different types of stainless steel. Because of their two phase structure, generally consisting of roughly 50% each of austenite and ferrite, greater scatter is naturally obtained for the duplex grades.

Alloy type	Condition	HRB	HRC	HV
Ferritics	Annealed	73 – 85		140 – 180
	Cold worked	90 – 100	13 – 25	180 – 290
Stabilised 11 % Cr ferritics	Annealed	67 – 83		120 – 170
Stabilised 17% Cr ferritics	Annealed	70 – 83		130 – 170
Austenitics	Solution annealed	74 – 88		130 – 185
	Cold worked		25 – 50	200 – 250
Duplex austenitic-ferritic	Solution annealed	90 – 105		
Martensitics	Softened	80 – 90		160 – 190
	Quenched and tempered		45 – 53	

Table 5.2.2 - Typical hardness ranges for the principal types of stainless steel

Impact testing

Impact testing is used to measure the toughness of a material, corresponding to the energy necessary to cause fracture under shock loading. Low toughness is generally associated with brittle shear fracture and high toughness with ductile plastic tearing. For materials prone to brittle frac-

ture, this phenomenon is promoted by the high strain rate and the use of a notched test-piece. The major experimental parameters which influence the toughness are the temperature, the notch geometry and the strain rate.

Test principle

The apparatus used for stainless steels, together with the specimen and notch geometries, are the same as for plain carbon steels. The most commonly employed technique is the Charpy test (fig. 5.2.5), in which the

10 x 10 mm section specimen, with a central V-notch, is struck by a freely falling pendulum. The ends of the specimen are supported from below and on the front side, with the notch vertical and facing forward, opposite

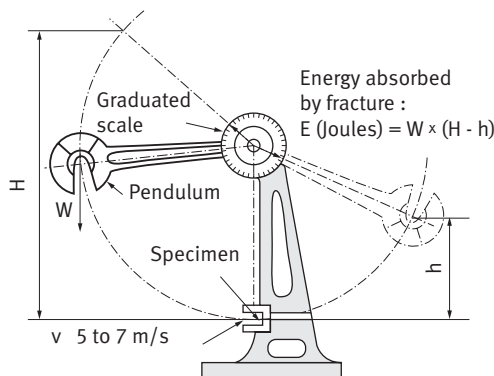

Schematic principle of the Charpy impact test

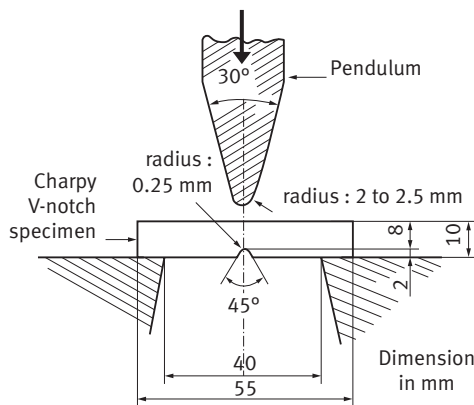

Detail of the pendulum and the Charpy V-notch specimen

Fig. 5.2.5 - The Charpy impact bending test

to the point of impact. The knife edge breaks the specimen and the pendulum rises to a height determined by the energy absorbed in fracture, E . Accurate measurement of the height of rise enables E to be calculated (in joules), and the impact strength K , in joules/cm², is then given by $K = E/A$, where A is the cross sectional area at the notch root, expressed in cm². Fracture can be either brittle or ductile. Brittle fracture involves decohesion or

cleavage, with no significant plastic strain. In this case, there is no lateral expansion of the specimen and the fracture surface is bright, with shiny facets. Ductile fracture is preceded by heavy plastic strain, accompanied by lateral expansion of the specimen, while the fracture surface has a mat, fibrous appearance. Certain materials show brittle behaviour, associated with low toughness (impact strength) at low temperatures, and high toughness ductile behaviour at high temperatures. Mixed behaviour is observed in the transition region between these two zones, which is characterized by the ductile-brittle transition temperature (fig. 5.2.6).

Fig. 5.2.6 - Effect of temperature in the Charpy V-notch impact strength. For the austenitic steel, temperature has relatively little effect, whereas for the ferritic grade a sharp transition is observed between ductile fracture (1) at high temperatures and brittle fracture (2) at low temperatures

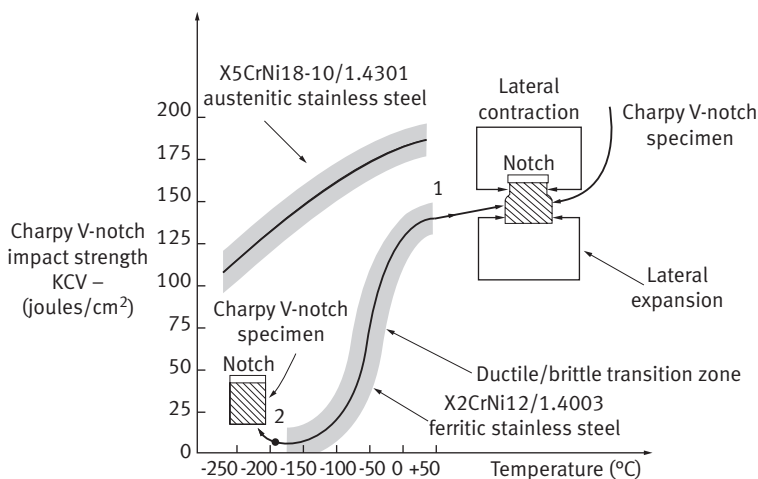

Table 5.2.3 - Typical impact strengths of different stainless steels at cryogenic temperatures

Alloy type	Temperature (°C)	KCV impact strength (J/cm ²)
Martensitic (X12Cr13/1.4006)	-40	35
	-60	30
	-196	8
Ferritic (X6Cr17/1.4016)	-40	15
	-60	10
	-196	3
Austenitic (X5CrNi18-10/1.4301)	-40	170
	-60	160
	-196	130
	-250	110

Behaviour of stainless steels and typical toughness values

The various types of stainless steels show quite different impact strengths, depending on their compositions and whether the microstructure is martensitic, ferritic, austenitic or duplex (Table 5.2.3). In the case of welds, different behaviours can be observed between the base metal, the heat affected zone and the fusion zone. In ferritic grades, an increase in chromium content raises the transition temperature, typically by about 50°C for an additional 4% of chromium. In contrast, brittle cleavage fracture does not generally occur in austenitic grades, such as X5CrNi18-10/1.4301, which consequently conserve a relatively constant impact strength, whatever the temperature. By way of example, Table 5.2.3 gives typical Charpy V-notch impact strength values for cryogenic temperatures between -40 and -250 °C.

6. Appendices

6.1 Physical and chemical properties of stainless steels

Why five families?

Stainless steels are iron alloys containing a minimum of approximately 11% chromium which is the key alloying element. Chromium in excess of 11% forms a tenacious protective film on any exposed surface; i.e. a corrosion barrier. To effectively prevent corrosion chromium must be in solid solution form and not combined as chromium carbides.

Martensitic stainless steels

Martensitic stainless steels have the highest carbon content (up to 1.2%). Their mechanical strength can be increased by quenching. The martensitic structure obtained is magnetic.

Ferritic stainless steels

Ferritic stainless steels have a low carbon content ($\leq 0.08\%$). For this reason, they do not display significant hardening after quenching. The ferritic structure is magnetic.

In the ferritic grades the toughness of the HAZ may be poor, due to grain growth during welding.

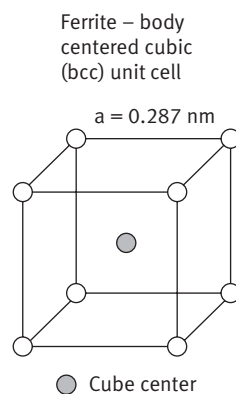
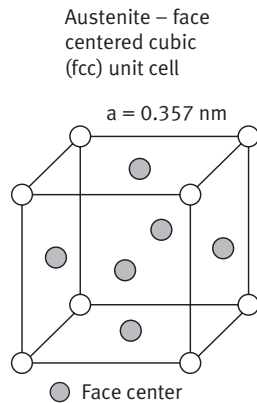

Photo 15: Professional kitchen knife. The blade is made of martensitic stainless steel.



Austenitic stainless steels

These alloys are the most popular grades of stainless steels because of their excellent formability and corrosion resistance. Due to the presence of austenite – stabilizing alloying additions, particularly nickel, these stainless steels have the face-centered cubic austenitic structure. They are not hardenable by heat treatment, but can be strain-hardened by cold-work.

Heat-resisting stainless steels

These iron – chromium – nickel grades have high strength at elevated temperatures and resistance to carburizing atmospheres. The basic chromium content is increased to 20-25% Cr and the nickel varies from 10-35%. All grades optimized for high temperature applications have high carbon contents.



Photo 16: Pump casing: the high ductility of austenitic stainless steels makes them suitable for one-piece designs combining deepdrawing and hydroforming techniques.

Photo 17: Duplex stainless steel bulkhead panels for chemical tankers



Duplex austenitic-ferritic stainless steels

The microstructures of duplex stainless steels consist of a mixture of austenite and ferrite. They exhibit characteristics of both phases with higher strength and ductility. Compared with austenite grades, duplex stainless steels show higher strength and markedly better corrosion resistance in chloride solutions.

Oxidation and oxides

Stainless steels exhibit excellent resistance to oxidizing environments. The one element essential in forming a high-temperature corrosion-resistant layer is chromium (so-called passive layer). The resulting compound is a crystalline oxide or hydroxide.

Oxidation is a process in which the proportion of the electronegative constituent in a compound is increased. In oxidation electrons are removed from the oxidized species.

An oxide is a compound of oxygen with another element. Oxides are divided into *acidic oxides* which react with bases to form salts; *basic oxides* which react with acids to form salts; *amphoteric oxides* which exhibit both basic and acidic properties.

In aqueous systems, an acid is defined as a substance which is capable of forming hydrogen ions when dissolved in water. Most inorganic acids may be regarded as a compound of an *acidic oxide* and water. When the oxide concerned is that of a metal, it may exhibit *amphoteric properties*, sometimes acting as an *acid* and sometimes as a *base*.



Photo 18: Burner part made of heat-resisting ferritic stainless steel

Typical physical properties (according to EN 10088-1)

Physical Properties		Families of Stainless Steel	Martensitic Grades	Ferritic Grades	Austenitic Grades	Austenitic-ferritic Grades
(kg/dm ³)	Density		7.7	7.7	7.9	7.8
(GPa)	Modulus of Elasticity at 20 °C:		215 000	220 000	200 000	200 000
(10 ⁻⁶ × K ⁻¹)	Coefficient of Thermal Expansion between 20 °C and 200 °C:		10.5	10	16	13.0
(W/(m × K))	Thermal conductivity at 20 °C:		30	25	15	15
(J/(kg × K))	Specific Heat Capacity at 20 °C:		460	460	500	500
(v × mm ² /m)	Electrical Resistivity at 20 °C:		0.55	0.60	0.73	0.80

6.2 Identification and Designation of Stainless Steels

European Designations

European Specifications which are used throughout the European Union

The European Standards were given the status of a national standard, either by publication of an identical text, or by endorsement, in October 1995, and conflicting national standards were withdrawn in October 1995.

According to the CEN/CENELEC Internal Regulations, the following countries are bound to implement this European Standard:

Austria, Belgium, Cyprus, Czech Republic, Denmark, Estonia, Finland, France, Germany, Greece, Hungary, Iceland, Ireland, Italy, Latvia, Lithuania, Luxembourg, Malta, Netherlands, Norway, Poland, Portugal, Slovakia, Slovenia, Spain, Sweden, Switzerland and United Kingdom.

Principal standards concerning stainless steels

Designation standards

EN 10027-1 Designation for steels – Part 1: Steel names, principal symbols

EN 10027-2 Designation for steels – Part 2: Numerical system

General purposes product standards

EN 10088-1 Stainless Steels – Part 1: List of stainless steels

EN 10088-2 Stainless Steels – Part 2: Technical delivery conditions for sheet/plate and strip for general purposes

EN 10088-3 Stainless Steels – Part 3: Technical delivery conditions for semi-finished products, bars, rods and sections for general purposes

prEN 10088-4 Stainless Steels – Part 4: Technical delivery conditions for sheet/plate and strip of corrosion for construction purposes

prEN 10088-5 Stainless Steels – Part 5: Technical delivery conditions for bars, rods, wire, sections and bright products of corrosion resisting steels for construction purposes

EN 10095- Heat-resisting steels and alloys

Pressure purposes product standards

EN 10028-7 Flat products made of steel for pressure purposes – Part 7: Stainless steels

EN 10272 Rolled bars made of stainless steel for pressure purposes

EN 10216-5 Seamless steel tubes for pressure purposes – Part 5: Technical delivery conditions-Stainless steel tubes

EN 10217-7 Welded steel tubes for pressure purposes – Part 7: Technical delivery conditions-Stainless steel tubes

EN 10222-5 Steel forgings for pressure purposes – Part 5: Martensitic, austenitic and austenitic-ferritic stainless steels

General purposes tube and fittings standards

EN 10296-2 Welded circular steel tubes for mechanical and general engineering purposes – Part 2: Technical delivery conditions-Stainless steel tubes

EN 10297-2 Seamless circular steel tubes for mechanical and general engineering purposes – Part 2: Technical delivery conditions-Stainless steel tubes

EN 10312 Welded stainless steel tubes and fittings for the conveyance of aqueous

liquids including water for human consumption: Technical delivery conditions

EN 12502-4 Protection of metallic materials against corrosion – Corrosion likelihood in water conveying systems – Part 4: Review of the influencing factors for stainless steels
Dimensional standards

ISO 9445 Continuously cold-rolled stainless steel narrow strip, wide strip, plate/sheet and cut lengths – Tolerances on dimensions and form (officially replaced EN 12058 and EN 12059 standards)

Welding consumables standards

EN 439 Welding consumables: Shielding gases for arc welding and cutting – Classification

EN 760 Welding consumables: Fluxes for submerged arc welding – Classification

EN 1600 Welding consumables: Covered electrodes for manual arc welding of stainless and heat-resisting steels-Classification

EN 12072 Welding consumables: Wire electrodes, wires and rods for arc welding of stainless and heat-resisting steels – Classification

ISO 17633 Welding consumables: Tubular cored electrodes and rods for gas shielded and non-gas shielded metal arc welding of stainless and heat-resisting steels – Classification (officially replaced EN 12073 standard)

Standard Designation of Stainless Steels

The steel names and steel numbers were established in accordance with EN 10027. The European standard for stainless steels is EN 10088 and the designation systems adopted in this standard are the EUROPEAN MATERIAL NUMBER and the MATERIAL NAME.

The material number comprises three parts, for example 1.4301, where: 1 denotes steel 43 denotes one group of stainless steels

(austenitic grades without Mo, Nb or Ti) and 01 is the individual grade identification.

The material name system provides some indication of the alloy composition, for example X5CrNi18-10, where: X denotes high alloy steel, 5: 100x % of carbon, Cr Ni: chemical symbols of main alloying elements, 18-10: % of main alloying elements.

Examples

- X20Cr13 / 1.4021

Steel with a carbon content of $20/100 = 0.2\%$ and a chromium content of 13%.

- X2CrTi12 / 1.4512

Steel with a carbon content of $2/100 = 0.02\%$ and a chromium content of 12% and with a titanium addition.

- X2CrNiMo17-12-2 / 1.4404

Steel with a carbon content of $2/100 = 0.02\%$ and a chromium content

of 17%, a nickel content of 12%, and a molybdenum content of 2%.

- X2CrNiMoN22-5-3 / 1.4462

Steel with a carbon content of $2/100 = 0.02\%$ and a chromium content of 22 %, a nickel content of 5%, a molybdenum content of 3%, and a nitrogen addition.

Equivalence between European Number and Name Designations and AISI Designations*

EN Number	European Designation	AISI or commercial designation
1.4000	X6Cr13	410S
1.4002	X6CrAl13	405
1.4003	X2CrNi12	403
1.4016	X6Cr17	430
1.4028	X30Cr13	420
1.4029	X29CrS13	420F
1.4057	X17CrNi16-22	431
1.4105	X6CrMoS17	430F
1.4113	X6CrMo17-1	434
1.4125	X105CrMo17	440C
1.4301	X5CrNi18-10	304
1.4303	X4CrNi18-12	305
1.4305	X8CrNiS18-9	303
1.4306	X2CrNi19-11	304L
1.4307	X2CrNi18-9	304L
1.4310	X9CrNi18-8	301
1.4311	X2CrNiN18-10	304LN
1.4335	X1CrNi25-21	310 S
1.4361	X1CrNiSi18-15-4	18.15
1.4362	X2CrNiN23-4	SAE2304
1.4372	X12CrMnNiN17-7-5	201
1.4373	X12CrMnNiN18-9-5	202
1.4401	X4CrNiMo17-12-2	316
1.4404	X2CrNiMo17-12-2	316L
1.4406	X2CrNiMoN17-11-2	316LN
1.4410	X2CrNiMoN25-7-4	2507
1.4434	X2CrNiMoN17-12-3	317LN
1.4438	X2CrNiMo18-15-4	317L
1.4439	X2CrNiMoN17-13-5	317L4
1.4460	X3CrNiMoN27-5-2	7Mo plus
1.4462	X2CrNiMoN22-5-3	2205
1.4466	X1CrNiMoN25-22-2	310MoLN
1.4501	X2CrNiMoCuWN25-7-4	Zeron 100
1.4507	X2CrNiMoCuN25-6-3	Ferralium 255
1.4509	X2CrTiNb18	441
1.4510	X3CrTi17	430Ti, 439
1.4511	X3CrNb17	430Nb
1.4512	X2CrTi12	409
1.4516	X6CrNiTi12	414
1.4521	X2CrMoTi18-2	444
1.4532	X8CrNiMoAl15-7-2	PH 15.7Mo
1.4537	X1CrNiMoCuN25-25-5	URSB8
1.4539	X1NiCrMoCu25-20-5	904L
1.4541	X6CrNiTi18-10	321
1.4542	X5CrNiCuNb16-4	630 17.4 (PH)
1.4550	X6CrNiNb18-10	347
1.4567	X3CrNiCu18-9-4	XM 7/18.9LW
1.4568	X7CrNiAl17-7	17.7PH
1.4571	X6CrNiMoTi17-12-2	316Ti
1.4580	X6CrNiMoNb17-12-2	316Cb

* Detailed information about the chemical, mechanical and physical properties of stainless steels is available from www.euro-inox.org/technical_tables (an interactive database) or from the printed brochure *Tables of Technical Properties* (Materials and Applications Series, Volume 5), Luxembourg: Euro Inox, 2005

6.3 Index, acronyms and abbreviations

Index

A

Abrasive powders and pads,	112	• Mechanical surface preparation,	98
Abrasive disk cutting,	34	• Medical applications,	101
Acid bath pickling,	98, 111	• Sandwich panels for curtain walling,	100
Acid-based cleaning reagents ,	113	• Transport equipment,	101
Activating flux (welding),	69, 71	• Pastes and mastics,	94
Adhesive bonding,	94	• Powdered or granulated adhesives,	94
• Adhesion,	96	• Setting or curing,	97
• Adhesion mechanisms,	96	• Surface preparation,	97
• Adhesive films and tapes,	95	• Surface wetting,	96
• Advantages of adhesive bonding for stainless steels,	97	• Thermoplastic adhesives,	95
• Application of the adhesive to the substrate,	97	• Thermosetting adhesives,	95
• Bonding procedures,	97	• Wall coverings,	100
• Chemical treatments,	98	Alkali-based cleaning reagents,	113
• Cleaning,	98	Anti-ferrite treatments,	22
• Decorative applications – monuments,	100	Argon Oxygen Decarburization (AOD),	24, 26, 27
• Design of adhesively bonded joints,	99	Arc welding,	66
• Joining,	97	Austenitic stainless steel,	13, 14, 15, 17, 22, 30, 31, 36, 39, 45,
• Laboratory results obtained with different adhesives,	99		116, 120, 121, 126
• Liquid adhesives,	94	Austenitic stainless steel tubes (hot tube bending),	62
• Major families of adhesives,	94	Austenitizing,	20
• Mastics,	95		

B

Band sawing,	34	• Manual bending,	46
Bending,	45	• Mechanical press brake bending,	46
• Calculation of the developed length of a profiled sheet,	48	• Open die bending,	46
• Closed die bending,	47	• Rubber pad bending,	48
• Elastic springback,	48	Blanking,	32
• Hydraulic press brake bending,	46	• Press punching,	32
		• Rotary shearing,	32

Bonding procedures,	97	Brightness,	107
Boring and reaming,	43, 44	Building and decorative applications (cleaning methods),	113
Brazing,	90	Butt welding	
• Furnace heating,	92	• Flash butt welding,	85
• Heating process,	90	• Resistance butt welding,	84
• Induction heating,	91	• Upset welding,	84
• Oxyacetylene torch heating,	90		
Brazing and soldering,	90		

C

Calculation of the developed length of a profiled sheet,	48	• Lubrication,	55
Characteristic hardness values for stainless steels,	122	• Modeling,	54
Characterization of surface condition,	106	• Roping and ridging,	56
• Brightness,	107	• Rubber pad bending,	48
• Roughness,	106	• Tooling,	54
Chemical analysis,	116	• Tube bending,	57, 58
Chemical treatments,	98, 110	• Tube hydroforming,	59
• Acid bath pickling,	98, 111	Collective catering equipment and domestic appliances (cleaning),	114
• Decontamination,	89, 112	Commercially available stainless steel products,	24
• Finishing treatments for welds,	112	Compatibility with stainless steels (cleaning reagents),	113
• Passivation,	89, 111	Cooling,	20, 21
• Prepickling or scale conditioning,	110	Corrosion,	5
Choice of a stainless steel grade,	16	Corrosion resistance	40
Choice of tools (machining),	41	• Corrosion,	5
Cleaning,	98	• Crevice corrosion,	6, 8, 9, 103
Cleaning for renovation,	114	• High temperature corrosion,	11
Cleaning methods,	113	• Intergranular corrosion,	6, 10
Cleaning on commissioning,	113	• Localized corrosion,	6
Cleaning reagents,	112	• Oxydizing atmospheres,	11
Clinching,	103	• Pitting corrosion,	6, 7
Closed die bending,	47	• Pitting potential,	7
Cold forming,	45	• Reducing atmospheres,	12
• Bending,	45	• Stress corrosion cracking,	6, 9
• Drawing,	49, 50, 51, 52, 53	• Uniform corrosion,	6
• Flowturning,	60	Crevice corrosion,	6, 8, 9, 103
• Lathe spinning,	59		

Clamping,	34	• Piercing,	33
Cutting – Thermal cutting	29	• Power hack sawing,	34
• Abrasive disk cutting,	34	• Punching,	29, 32, 33
• Band sawing,	34	• Rotary shearing,	32
• Heat Affected Zone (HAZ),	36	• Sawing,	29, 34
• Laser beam cutting,	36	• Shearing,	29, 30, 31
• Manual sawing,	34	• Shearing forces,	30
• Milling cutter sawing,	34	• Slitting,	31, 32
• Nibbling,	33	• Straight-blade shearing,	30
• Oxygen-acetylene torch cutting,	35	• Thermal cutting,	29, 35
• Plasma-arc cutting,	36	• Water jet cutting,	35
• Perforating,	33		
D			
Decontamination,	112	Detergents and soaps,	112
Decorative applications – monuments,	100	Disinfectants,	113
Design of adhesively bonded joints,	99	Drawing,	49, 50, 51, 52, 53
Degreasing in hot alkali baths,	98	Drilling,	42, 43
Delayed cracking,	57	Duplex austenitic – ferritic stainless steels,	13, 14, 15, 18, 117, 126
E			
Effect of non-metallic inclusions (machining),	40	Electrical resistance welding,	81
Elastic springback (bending),	48	Electron Beam Welding (EBW),	88
F			
Ferritic stainless steels, 13, 14, 15, 18, 21, 39, 117, 125		Flat products,	24, 25
Ferritic stainless steels (hot tube bending),	62	Flowturning,	60
Finishing operations (hot tube bending),	62	Flux Cored Arc Welding (FCAW),	75
Finishing treatments,	89, 112	Food processing equipment (cleaning),	114
Flash Welding (FW),	85	Forming limit curves,	53, 54
Flash butt welding,	85	Forms of corrosion,	5
		Friction butt welding,	88
		Furnace heating (brazing),	92

G

Gas Metal Arc Welding (GMAW),	72, 74
Gas Tungsten Arc Welding (GTAW),	66, 67, 69, 71

H

Hardness tests,	122, 123	Heating process (brazing),	90
Heat Affected Zone (HAZ),	36, 77, 124	High Frequency Induction Welding (HFIW),	86, 88
Heat-resisting stainless steels,	13, 14, 19, 126	High temperature corrosion,	11
Heat treatment		Hot forming,	61, 62
• Austenitizing,	20	Hot tube bending,	62
• Cooling,	20, 21	Hydraulic press brake bending,	46

I

Impact testing,	123	Intergranular corrosion,	6, 10
Induction heating (brazing),	91		

J

Joining (adhesive bonding),	97	Joining operations,	63
-----------------------------	----	---------------------	----

L

Laboratory results obtained with different adhesives,	99	Long products,	27
Laser beam cutting,	36	Lubrication (drawing),	55
Laser Beam Welding (LBW),	87		
Lathe spinning,	59		
Lathe turning,	42		
Liquid adhesives,	94		
Localized corrosion,	6		
Lockseaming,	103, 104		

M

Machinability criteria,	38	Manual bending,	46
Machining,	38	Manual sawing,	34
• Behaviour of the different types of stainless steel,	39	Marangoni effect,	70
• Boring and reaming,	43	Martensitic stainless steel,	13, 14, 15, 19, 20, 39, 111, 121, 125
• Choice of tools,	41	Mastics,	95
• Drilling,	42, 43	Mechanical joining,	102
• Effect of non-metallic inclusions,	40	Mechanical press brake bending,	46
• Lathe turning,	42	Mechanical surface preparation (adhesive bonding),	98
• Machinability criteria,	38	Medical applications (adhesive bonding),	101
• Milling,	44	Metal Inert Gas (MIG) welding,	72, 73, 75
• Oxide inclusions,	40	Metallographic examination,	116
• Sulfide inclusions,	40	Metallurgical testing and inspection,	116
• Synergism between the effects of sulfur and malleable oxides,	40	Milling,	44
• Tapping,	44	Milling cutter sawing,	34
• Threading,	44	Modeling (drawing),	54
Major families of adhesives,	94		
Major families of stainless steels,	13		

N

Nibbling,	33		
-----------	----	--	--

O

Open die bending,	46	Oxygen-acetylene torch cutting,	35
Oxide inclusions (machining),	40	Oxyacetylene torch heating (brazing),	90
Oxidizing atmospheres,	11, 110, 111		

P

Passivating baths,	89	Pastes and mastics,	94
Passivating pastes and gels,	89	Peening,	109
Passivation,	89, 111	Pickling,	89

Pickling baths,	89	Power hack sawing,	34
Pickling followed by anodizing,	98	Preparation of stainless surfaces,	98
Pickling pastes and gels,	89	Prepickling of scale conditioning,	110
Piercing,	33	Press punching,	32
Pitting corrosion,	6, 7	Principal applications,	15
Pitting potential,	7	Principal surface conditions,	107
Plasma-arc cutting,	36	Principle and theoretical basis (drawing),	49
Plasma Arc Welding (PAW),	76, 77	Protection of the surfaces of stainless steel sheets,	45
Polishing,	110	Protective waxes,	113
Post-weld heat treatment,	23	Punching,	29, 32, 33
Powdered or granulated adhesives,	94		

R

Reducing atmospheres,	12	Roping and ridging,	56
Resistance butt welding,	84	Rotary shearing,	32
Resistance Seam Welding (RSEW or SW),	83, 84	Roughness,	106
Resistance Spot Welding (RSW),	81, 82	Routine maintenance cleaning,	114
Riveting,	102	Rubber pad bending,	48

S

Sand blasting and glass bead peening,	109	Stainless steel families	
Sandwich panels for curtain walling,	100	• Austenitic,	13, 14, 15, 17, 22, 30, 31, 36, 111, 121, 126
Sawing,	29, 34	• Duplex austenitic – ferritic,	13, 14, 15, 18, 23, 121, 126
Screwing and bolting,	102	• Ferritic,	13, 14, 15, 18, 21, 111, 121, 125
Setting or curing,	97	• Heat resisting,	13, 14, 19, 126
Shearing,	29, 30, 31	• Martensitic,	13, 14, 15, 19, 20, 39, 111, 125
Shearing forces,	30	Straight-blade shearing,	30
Shielded Metal Arc Welding (SMAW),	80	Stress corrosion cracking,	6, 9
Slitting,	31, 32	Stress relieving treatments,	22
Soldering,	93	Submerged Arc Welding (SAW),	77, 79
Solution annealing,	22, 23	Sulfide inclusions (machining),	40
Solvent degreasing (adhesive bonding),	98		
Solvents,	113		

Surface condition,	105	Surface Tension Transfer (STT) (welding),	75
Surface preparation,	97	Surface wetting (adhesive bonding),	96
Surface preparation and treatments,	109	Synergism between the effects of sulfur and malleable oxides,	40
T			
		Tube bending,	57, 58
Tapping,	44	Tube expansion,	104
Tension tests,	119	Tube hydroforming,	59
Thermal cutting,	29, 35	Tubes,	28
Thermoplastic adhesives,	95	Tungsten Inert Gas	
Thermosetting adhesives,	95	(TIG) welding,	66, 68, 69, 74, 76, 77
Threading,	44	Typical mechanical properties of the different stainless steels in various conditions,	121
Three-roll forming,	49		
Tooling (cold forming),	54		
Transport equipment (adhesive bonding),	101		
U			
Uniform corrosion,	6	Upset welding (UW),	84
V			
Variants of resistance welding,	84		
W			
Wall coverings (adhesive bonding),	100	• Electron Beam Welding (EBW),	88
Water jet cutting,	35	• Flash Welding (FW),	85
Weld,	86	• Flux Cored Arc Welding (FCAW),	75
Weld pool,	70, 71	• Friction butt welding,	88
Welding,	63	• Gas Metal Arc Welding (GMAW),	72, 74
• Activating flux,	69, 71	• Gas Tungsten Arc Welding (GTAW),	66, 67, 69, 71
• Arc welding,	66	• High Frequency Induction Welding (HFIW),	86, 88
• Electrical resistance welding,	81		

- Heat affected zone (HAZ), 77
- Laser Beam Welding (LBW), 87
- Marangoni effect, 70
- Metal Inert Gas (MIG) welding, 72, 73, 75
- Plasma Arc Welding (PAW), 76, 77
- Resistance butt welding, 84
- Resistance Seam Welding (RSEW), 83, 84,
- Resistance Spot Welding (RSW), 81, 82
- Shielded Metal Arc Welding (SMAW), 80
- Submerged Arc Welding (SAW), 77, 79
- Surface Tension Transfer (STT), 75
- Tungsten Inert Gas (TIG) welding, 66, 68, 69, 74, 76, 77
- Upset Welding (UW), 84
- Variants of resistance welding, 84
- Weld, 86
- Weld pool, 70, 71
- Welding current, 67, 74, 75, 77, 79, 80, 82, 84
- Welding parameters, 74, 77, 79, 80, 82, 84, 85
- Welding processes, 66, 88
- Welding Research Council (WRC), 63
- Welding rolls, 86
- Wheel grinding, 109

Acronyms and abbreviations

°C	: Celsius degree	J	: Joule (energy) - (metric unit)
AISI	: American Iron and Steel Institute	K	: Crack tip stress field intensity factor (fracture mechanics)
AOD	: Argon-Oxygen Decarburization (melting process)	kg	: Kilogram
ASTM	: American Society for Testing and Materials	KCV	: Charpy impact energy absorption (toughness)
A-TIG	: Activating flux TIG (welding)	LBW	: Laser Beam Welding (welding)
AWS	: American Welding Society	LCC	: Life Cycle Costing (global costing)
CERMET	: CERamic – METal (machining)	LDR	: Limiting Drawing Ratio (drawing)
CR	: Cold Rolled (rolling)	MF	: Medium Frequency (welding, brazing)
CVD	: Chemical Vapor Deposition (machining)	MIG	: Metal Inert Gas (welding)
EL	: Elongation (%)	N	: Newton (force)
EVA	: Ethyl Vinyl Acetate (bonding)	PAW	: Plasma Arc Welding (welding)
FCAW	: Flux Cored Arc Welding (welding)	PVD	: Physical Vapor Deposition (machining)
FW	: Flash Welding (welding)	RSW	: Resistance Spot Welding (welding)
GMAW	: Gas Metal Arc Welding (welding)	SAW	: Submerged Arc Welding (welding)
GTAW	: Gas Tungsten Arc Welding (welding)	SMAW	: Shielded Metal Arc Welding (welding)
HAZ	: Heat Affected Zone (welding, thermal cutting)	STT	: Surface Tension Transfer (welding)
HB	: Brinell Hardness number (hardness)	SW	: Seam Welding (welding)
HF	: High Frequency (welding, brazing)	TIG	: Tungsten Inert Gas (welding)
HFIW	: High Frequency Induction Welding (welding)	UTS	: Ultimate Tensile Strength (N/mm ²)
HR	: Hot Rolled (rolling)	UW	: Upset Welding (welding)
HRB	: Rockwell B. Hardness number (hardness)	WIG	: Wolfram Inert Gas (welding)
HRC	: Rockwell C. Hardness number (hardness)	YAG	: Yttrium-Aluminium-Garnet (laser welding, thermal cutting)
HSS	: High Speed Steels (machining)	YS	: Yield Strength (N/mm ²)
HV	: Vickers Hardness number (hardness)		

6.4 Reference list of illustrations and photo credits

- Cover: Bioreactor
 manufacturer: Pierre Guérin Technologies, Mauze (F) – photo: idem
- 1: Bright annealing line
 p. 5
 manufacturer: Drever International, Liège (B) – photo: idem
- 2: Atomium, Brussels (B) p. 6
 owner: asbl Atomium – architect : C. Conix – structural engineering : temporary association Bgroup – Geocal – photo: Thomas Pauly – © 2006 asbl Atomium – SABAM, Belgium 2006
- 3: Slitting line in action p. 24
 manufacturer: Fagor Arrasate, Mondragon (E) – photo : idem
- 4: Hydraulic guillotine shear p. 29
 manufacturer : LVD Company nv, Gullegem (B) – photo: idem
- 5: Coated carbide insert p. 41
 manufacturer : Seco Tools AB, Fagersta (S) – photo: idem
- 6: Coated CERMET insert p. 41
 photo: UGITECH, Ugine (F)
- 7: The glass-steel structure of the lens of the Rome yard p. 61
 owner: Régie autonome des transports parisiens (RATP) – architect: Arté – Charpentier et associés – structural engineering : RFR Ingénieurs (Project engineer: Mitsu Edwards) – photo: Mitsu Edwards – © RATP
- 8: Hot extruded sections p. 62
 manufacturer: Cefival, Persan (F) – photo : idem
- 9: Manual Gas Tungsten Arc Welding p. 64
 photo: © 2006 ESAB, Gothenburg (S)
- 10: Fasteners p. 102
 photo : Benoît Van Hecke
- 11: Milk pasteurizing plant p. 105
 manufacturer: Pierre Guérin Technologies, Mauze (F) – photo: idem
- 12: Surface finishing p. 109
 manufacturer: Otto Suhner, Brugg (CH) – photo: idem
- 13: Tensile testing p. 115
 manufacturer: Zwick, Ulm (D) – photo: idem
- 14: Steam pressure cooker p. 118
 manufacturer: SEB, Selongey (F) – photo: idem
- 15: Professional kitchen knife p. 125
 manufacturer: Wüsthof, Solingen (D) – photo: idem
- 16: Pump casing p. 126
 manufacturer: Ebara Pumps Europe, Cles (I) – photo: idem
- 17: Bulkhead panels for chemical tankers p. 126
 manufacturer – shipyard: Cantieri Navali De Poli, Pellestrina (I) – photo: idem
- 18: Burner part p. 127
 manufacturer: Bekaert Combustion Technology, Assen (NL) – photo: idem

6.5 Bibliographical references

- 1 COLOMBIER (L), HOCHMANN (J), “Aciers inoxydables et Aciers réfractaires”, *Dunod*, Paris, 1965. English translation by Scripta Technica Ltd., *Stainless and Heat Resistant Steels*, Edward Arnold Publishers Ltd., London, 1967
- 2 “La construction chaudronnée en acier inoxydable”, Ugine Kuhlmann – aciers spéciaux, Paris, 1969
- 3 “La pièce mécanique en acier inoxydable”, Ugine Aciers, Paris, 1973
- 4 “Les aciers inoxydables” (ouvrage collectif), éditeurs scientifiques : LACOMBE (P), BAROUX (B) et BÉRANGER (G), les Editions de Physique, Les Ulis, 1990. English translation by DAVIDSON (J.H.) and LINDQUIST (J.B.), *Stainless Steels*, les Editions de Physique (Publishers), les Ulis, 1993
- 5 CUNAT (P-J), « Aciers inoxydables. Critères de choix et structure (M 4 540); Propriétés. Résistance à la corrosion (M 4 541); Mise en œuvre (M 4 542); Fabrication (M 4 543) », *Techniques de l'Ingénieur, traité Matériaux métalliques*, Paris, 2000. English translation by Davidson (J.H.), *The Euro Inox Handbook of Stainless Steel*, Euro Inox, Luxemburg, 2002.
- 6 “Design Manual for Structural Stainless Steel”, Third Edition, Luxembourg: Euro Inox 2006
- 7 “Guide du collage de l'acier inoxydable / Guide to adhesive bonding of stainless steel”, Document Ugine, *La Défense*, 1996
- 8 Association Ouvrière des Compagnons du Devoir du Tour de France et la collaboration de G. Murry, coordinateur, *Travailler l'Acier – Manuel de l'Artisan et du Technicien*, Editions *SIRPE*, Paris, 1996 .
- 9 MOIRON (J-L) avec le concours de BONNEFOIS (B) et CUNAT (P-J), “Souder les aciers inoxydables”, *SIRPE*, Paris, 2000

ISBN 978-2-87997-181-0