

## Innovative Facades in Stainless Steel

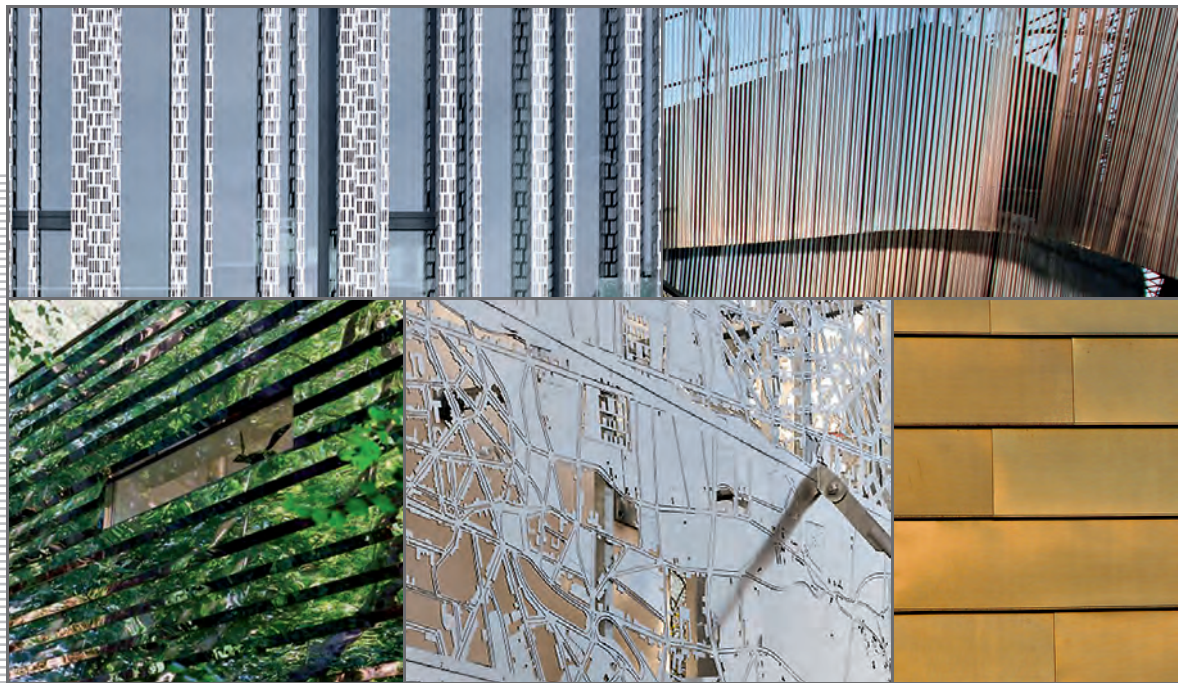

## Euro Inox

Euro Inox is the European market development association for stainless steel.

The members of Euro Inox include:

- European stainless steel producers
- National stainless steel development associations
- Development associations of the alloying element industries.

A prime objective of Euro Inox is to create awareness of the unique properties of stainless steels and to further their use in existing applications and in new markets. To this purpose, Euro Inox organises conferences and seminars and issues guidance in printed form and electronic format, to enable architects, designers, specifiers, fabricators and end users to become more familiar with the material. Euro Inox also supports technical and market research.

### Disclaimer

Euro Inox has made every effort to ensure that the information presented in this document is technically correct. The reader is advised that the material contained herein is for general information purposes only. Euro Inox, its members, staff and consultants specifically disclaim any liability or responsibility for loss, damage, or injury resulting from the use of the information contained in this publication. No part of this publication may be reproduced, stored in a retrieval system, or transmitted in any form or by any means, electronic, mechanical, photocopying, recording or otherwise, without the prior written permission of the publisher.

### Full members

**Acciai Speciali Terni**  
www.acciaiterni.com

**Acerinox**  
www.acerinox.com

**Aperam**  
www.aperam.com

**Outokumpu**  
www.outokumpu.com

### Associated members

**Acroni**  
www.acroni.si

**British Stainless Steel Association (BSSA)**  
www.bssa.org.uk

**Cedinox**  
www.cedinox.es

**Centro Inox**  
www.centroinox.it

**ConstruirAcier**  
www.construiracier.fr

**Industeel**  
www.industeel.info

**Informationsstelle Edelstahl Rostfrei**  
www.edelstahl-rostfrei.de

**International Chromium Development Association (ICDA)**, www.icdacr.com

**International Molybdenum Association (IMOA)**  
www.imoa.info

**Nickel Institute**  
www.nickelinstitute.org

**Paslanmaz Çelik Derneği (PASDER)**  
www.turkpasder.com

**Polska Unia Dystrybutorów Stali (PUDS)**  
www.puds.pl

**Stowarzyszenie Stal Nierdzewna (SSN)**  
www.stalnierdzewne.pl

**SWISS INOX**  
www.swissinox.ch

## Impressum

Innovative Facades in Stainless Steel  
 First edition 2013 (Building Series, Volume 19)  
 ISBN 978-2-87997-372-2  
 © Euro Inox 2013

Czech version	ISBN 978-2-87997-373-9
Dutch version	ISBN 978-2-87997-379-1
Finnish version	ISBN 978-2-87997-377-7
French version	ISBN 978-2-87997-376-0
German version	ISBN 978-2-87997-374-6
Italian version	ISBN 978-2-87997-378-4
Polish version	ISBN 978-2-87997-380-7
Spanish version	ISBN 978-2-87997-375-3
Swedish version	ISBN 978-2-87997-381-4
Turkish version	ISBN 978-2-87997-382-1

### Publisher

Euro Inox  
 Diamant Building  
 Bd. A. Reyers 80  
 1030 Brussels  
 Belgium  
 Tel. +32 2 706 82 67  
 Fax +32 2 706 82 69  
 E-mail [info@euro-inox.org](mailto:info@euro-inox.org)  
 Internet [www.euro-inox.org](http://www.euro-inox.org)

### Author

Martina Helzel, circa drei, Munich, Germany  
 (concept, text, design)  
 Philip Thrift, Hanover, Germany (translation)

## Contents

Introduction	2
Café and crèche in Brussels, Belgium	4
Studio in Berlin, Germany	6
Multi-storey car park in Almere, Netherlands	8
Hotel in Zug, Switzerland	10
Company HQ in Segrate near Milan, Italy	12
Office building in Brussels, Belgium	15
Office blocks in Hamburg, Germany	16
Fire station in Bruges, France	18
Holiday home in Thorington, England	20
Archive in Bure, France	22
Office building in Hamburg, Germany	24
Government offices in Nantes, France	26
Computer centre in Garching, Germany	28
University building in Lausanne, Switzerland	30
Office building in Madrid, Spain	32
Congress centre in Stockholm, Sweden	34

## Introduction

Stainless steel started to be used in the building industry just a few years after its invention about 100 years ago. The first time was in 1929, on the Chrysler Building in New York, whose apex is still adorned by 4 500 large-format stainless steel tiles. Stainless steel facades are also popular with the designers and clients of new skyscrapers, such as the Petronas Towers in Kuala Lumpur or the Burj Khalifa in Dubai, currently the world's tallest building. It was at the Bibliothèque Nationale de France in Paris in 1992 that the success story of woven stainless steel began.

For a long time, stainless steel was mainly reserved for the facades of large, eminent buildings. It is the prestige – less often the technical – image of the material that has undergone a significant transformation in recent years.

*Wide strips of shiny stainless steel woven together lend a vividness and depth to the windowed facade of this office building in Hamburg. Architects: BRT Architekten, Hamburg*



Photo: Klaus Frahm



Photo: GKD

*The decorative woven metal, bead-blasted using a special technique, shades the occupants from the sun.*

New developments in processing and fabrication plus the growing importance of sustainable design are helping to increase the popularity of stainless steel facades – for smaller structures, too.

Remarkable examples are to be found not only in new-build projects, but also in the refurbishment of and extensions to existing buildings. The combination with concrete, masonry, timber or coated sheet steel results in new design options. Stainless steel is also a good choice for facade structures with technical functions such as shading, redirecting the light or electromagnetic shielding.

Protected by its unique layer of oxide, which re-forms continuously from the chromium-rich alloy and oxygen, stainless steel needs no applied coatings. Its corrosion resistance makes it – through the choice of the right grade for the particular application – an



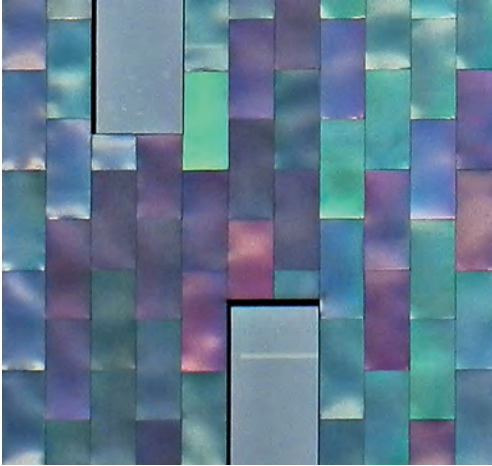

Photo: Rimex

*The appearance of the sheets on this facade (coloured in an electrolytic process) changes with the incidence of the light.*

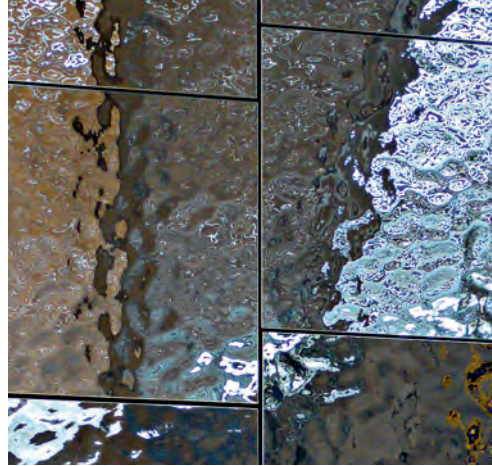

Photo: Exyd

*The random, three-dimensional form of these stainless steel sheets is due to a computer-controlled pressing process.*

extremely long-lasting, easy-care and low-maintenance material. These properties play a major role when considering the life cycle costs, and place the sometimes higher initial investment in a new light. Furthermore, durability is a factor in the calculations of sustainability and certification systems, which are growing in importance.

The stainless steel options used for facades are just as diverse as the applications and products themselves. Sheets, meshes, gratings and woven fabrics, expanded metal or sections with natural, matt, embossed, satin-polished or coloured surface finishes

provide designers with a wide range of options. In addition, the enormous progress in the area of computer-controlled milling, laser and water-jet cutting methods and newly developed three-dimensional shaping techniques expand the scope for creativity in imaginative facade designs.<sup>1</sup>

Photo: Stamers Kontor



*Distorted reflections in the sheets of polished stainless steel turn this children's playhouse into a special experience. Architects: MLRP, Copenhagen*

1 "Depth, Pattern and Texture – The Third Dimension in Stainless Steel Surfaces", Building Series, vol. 14



**Café and crèche in Brussels, Belgium**

Client:  
Ixelles local authority, Brussels  
Architects:  
B612 associates, Brussels  
Structural engineers:  
Bgroup Greisch, Brussels

During the course of refurbishment work, a conspicuous extension was added to this prestigious building, partly protected by a conservation order, in Ixelles, a district of Brussels. The new rooms accommodate a crèche and a public café to supplement the existing cultural facilities in the main building.

In order to achieve more transparency and interaction between street, building and park, openings were formed in existing walls and the extension was given a facade of laser-cut stainless steel. The patterns cut in this expressive metal cladding are based on maps of the historical development of this area of the city. So the net-like design for the garden wall, canopy and cladding tells the story of how this location steadily became more and more built-up.

*The design concept with its sheets of stainless steel continues through from the exterior to the interior.*



Photos: Serge Brison (top); Bernard Boccara (bottom)

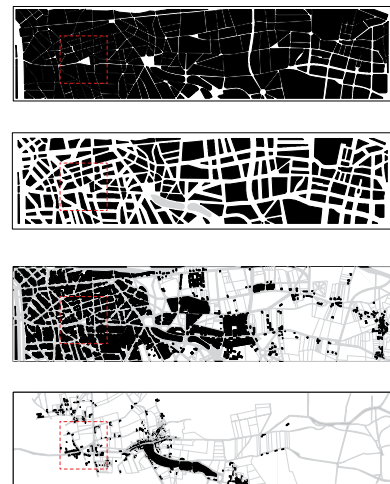

Graphic development of the patterns based on maps



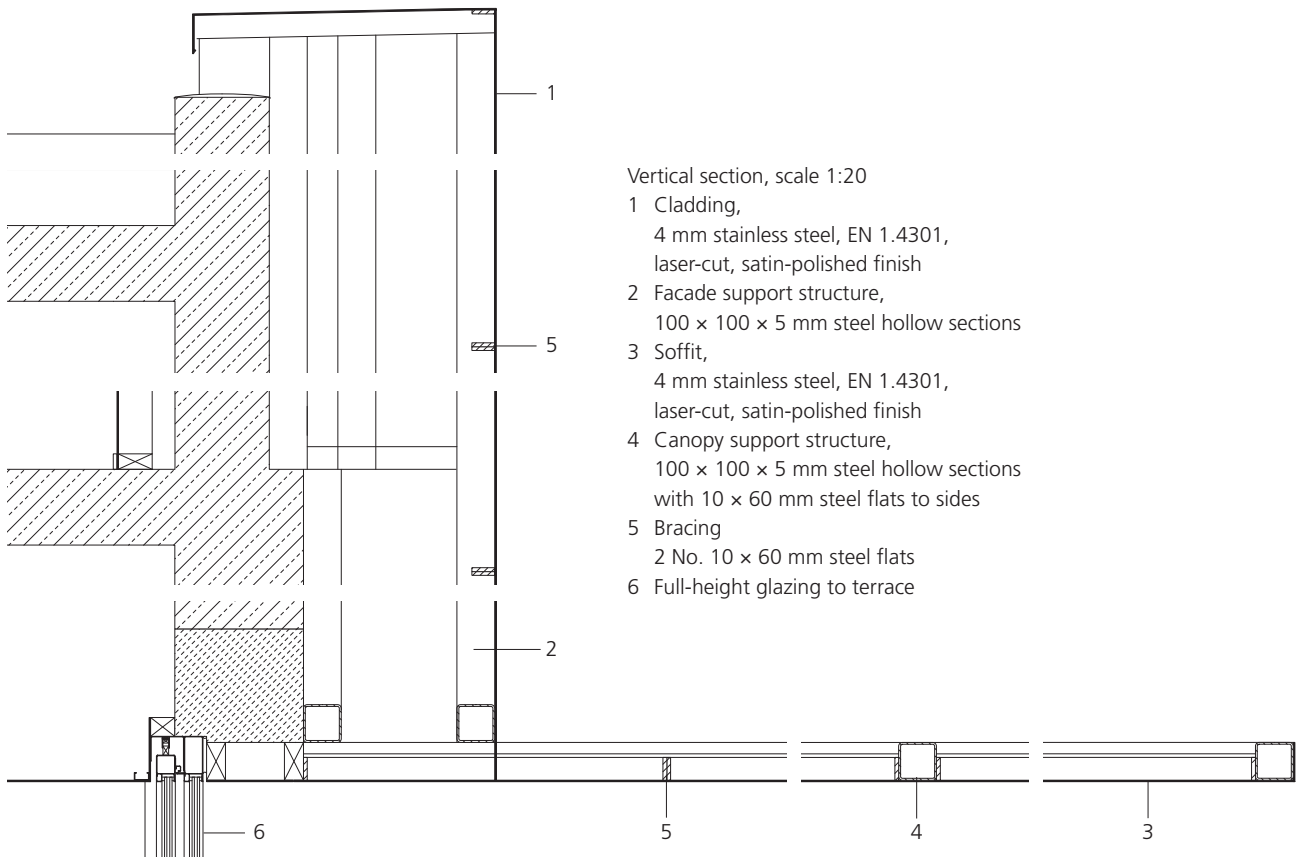

*Many variations and degrees of transparency are possible with the laser-cut sheets of stainless steel depending on which maps were used to generate the patterns.*

Photo: Serge Brison

### Studio in Berlin, Germany

Client:

private

Architects:

Buchner + Wienke, Berlin

with A. Spieth, M. Oehler

An old ancillary building in the garden of a large, imposing house in the Treptow district of Berlin has been converted into a retreat for creative thought. The simple, two-storey structure is concealed behind a cladding of

mirror-polished stainless steel. The horizontal panels in front of a ventilation cavity are made from sheets just 1 mm thick, which are folded to give them the necessary stiffness. They are fixed to the supporting framework with a push-fit connection and concealed screws.

Undisturbed working has been ensured by minimising the sizes of the window openings. The windows required as fire escapes are concealed behind opening panels integrated into the cladding. The mirror-polished panels reveal hardly anything of the interior of this building. Instead, they reflect the lush vegetation of the surrounding garden.

*One effect of the reflective facade is that the studio's appearance seems to adapt to the changing seasons.*





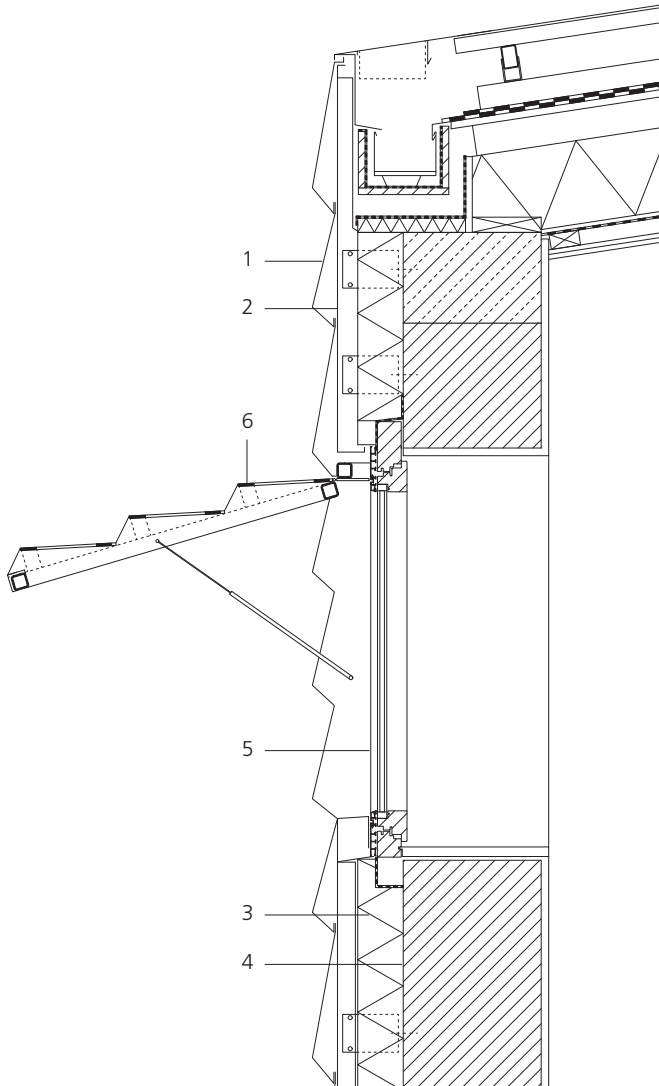

*This large window is rather an exception in this building and allows a view over the garden.*

Vertical section, scale 1:20

- 1 Facade panel,  
1 mm stainless steel, EN 1.4301,  
folded, electropolished
- 2 Lightweight metal supporting  
framework
- 3 Thermal insulation, 160 mm
- 4 Masonry, 365 mm
- 5 Timber/aluminium window
- 6 Opening panel on gas springs,  
fitted to steel frame



*The varying dimensions of the panels are hardly noticeable at first sight but help to make this facade design highly exciting.*

Photos: Marcus Bredt



### Multi-storey car park in Almere, Netherlands

Client:

Almere local authority

Architects:

mei architecten en stedenbouwers,  
Rotterdam

Structural engineers:

Pieters Bouwtechniek, Almere/Delft

A clearly structured built environment and plenty of greenery characterise Buiten, a new district in Almere. One measure in the expansion of the city centre is Block 11, a multi-storey car park with 413 spaces which fits neatly into the urban concept. It is primarily the innovative, imaginative facade of this imposing structure that catches the eye.

*Stainless steel panels with the typical motifs of the Dutch province of Flevoland together with the integral plant containers help to make the appearance of this structure unmistakable.*

*The perforations in the stainless steel sheets enable a natural exchange of air in the car park and create an open, transparent feeling.*



Photos: Jeroen Musch



Windmills, garden gnomes and birdhouses decorate the stainless steel facade panels, which number about 1200. The three-dimensional motifs were transferred to the sheets with the help of a special deep-drawing technique used in the automotive industry. Perforations were then cut in the sheets to ensure natural air circulation through the building. Plant containers regularly spaced over the facade provide a variation on the “green facade” theme. The choice of plants depends on the orientation of the facade and supplements the unusual design of this “gnome garage”.

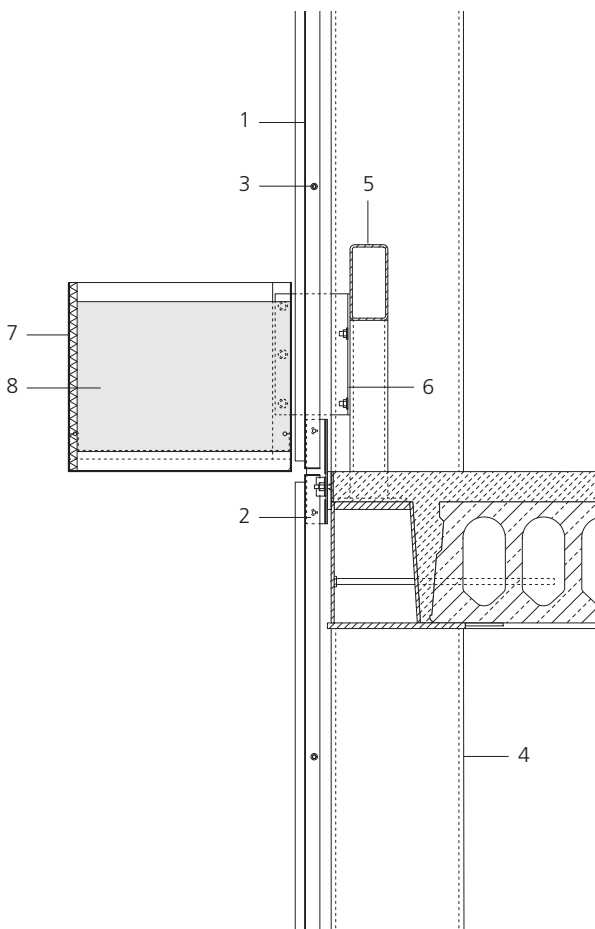

Vertical section, scale 1:20

- 1 Facade panel,  
1.2 mm stainless steel, EN 1.4401,  
40% perforations, deep drawn and  
folded, 2B finish
- 2 Fixing bracket,  
4 mm stainless steel flat
- 3 Horizontal connection between panels,  
M10 stainless steel bolt with plastic  
spacer
- 4 Facade column  
350 × 350 mm steel hollow section
- 5 Safety barrier
- 6 Fixing bracket for plant container,  
welded from 6 mm stainless steel flats
- 7 Cladding to plant container,  
3 mm stainless steel, EN 1.4401,  
2B finish
- 8 Plant container with automatic  
watering

*During the day the six floors of the car park are concealed behind the regular structure of the shimmering facade. Only at night does the car park lighting reveal the interior.*





*The monotonous appearance of so many hotels is avoided here by the returns and reflections in the facade.*

### **Hotel in Zug, Switzerland**

Client:  
MZ-Immobilien AG, Zug  
Architects:  
EM2N Architekten AG, Zurich  
Structural engineers:  
Berchtold + Eicher, Zug  
Pirmin Jung Ingenieure für Holzbau AG,  
Rain

A building that in just 12–15 years' time will have to make way for a planned road project has been built on a piece of public land to serve as a temporary annex to the Parkhotel in Zug. Despite its short payback period, this four-star hotel has been given an unmistakable character. As the rooms are positioned at a slight angle, the highly reflective facade has acquired a certain depth. The resulting interior corridors have a zigzag floor plan.



Plan of 1<sup>st</sup> floor, scale 1:500

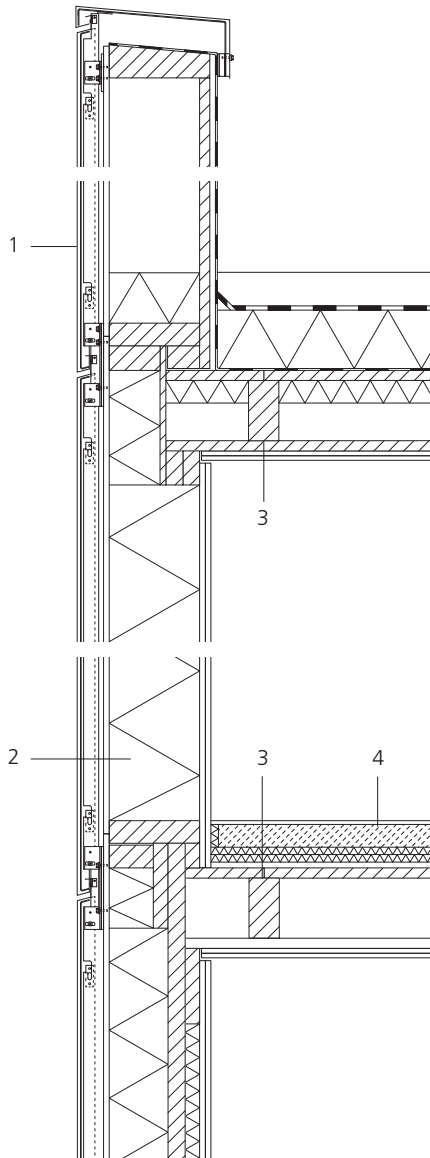

Vertical section, scale 1:20

- 1 Cladding,  
1 mm stainless steel, EN 1.4301,  
mirror-polished, on metal framework
- 2 Wall construction,  
60 × 240 mm timber studs and  
mineral-fibre insulation
- 3 Floor construction,  
80 × 160 mm timber joists and  
filling of limestone chippings
- 4 Cement screed on impact sound insulation

The four-storey structure, with about 4 000 m<sup>2</sup> of floor space for 82 rooms and a restaurant, is based on a timber structure and stiffening concrete cores. Suspended, storey-high panels made from stainless steel sheets, which ensure multi-faceted reflections of the surroundings, clad the building. The use of prefabricated elements enabled the annex to be built in just nine months.

*The high quality standards for this temporary structure are also evident in its facade made of stainless steel.*

Photos: Roger Frei







**Company HQ in Segrate near Milan, Italy**

Client:  
 Friem S.p.A., Segrate  
 Architects:  
 onsitestudio, Milan  
 Structural engineers:  
 CeAS, Milan

A manufacturer of transformers has erected its company headquarters on an industrial estate to the east of Milan. The ground floor of this L-shaped building houses laboratories and workshops for development and production; the upper floor is reserved for offices and management. Visible from afar down a major arterial road is the tower-like structure enclosing the fire escape stairs plus roof-mounted air-conditioning and other plant.

*Even the rooftop plant is hidden behind stainless steel to match the rest of the facade.*

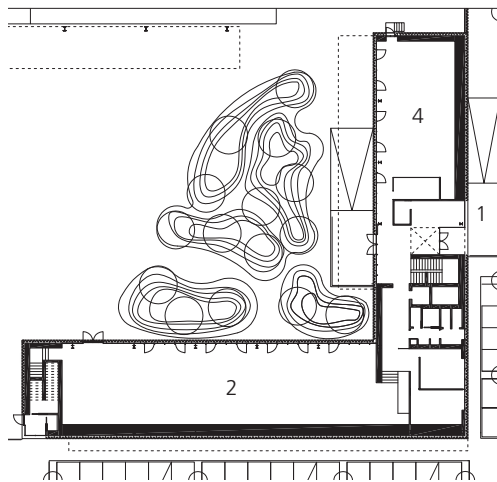

Plan of ground floor

Plans, scale 1:800  
 1 Main entrance  
 2 Workshop/laboratory  
 3 Management  
 4 Office  
 5 Meeting room

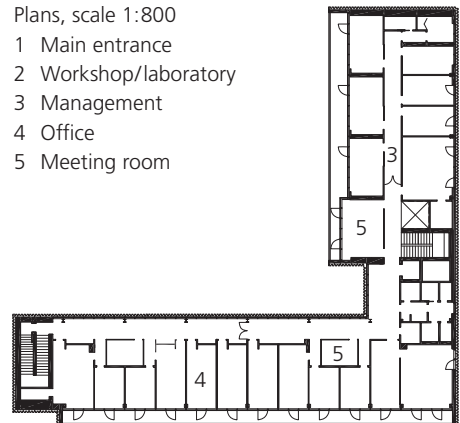

Plan of upper floor



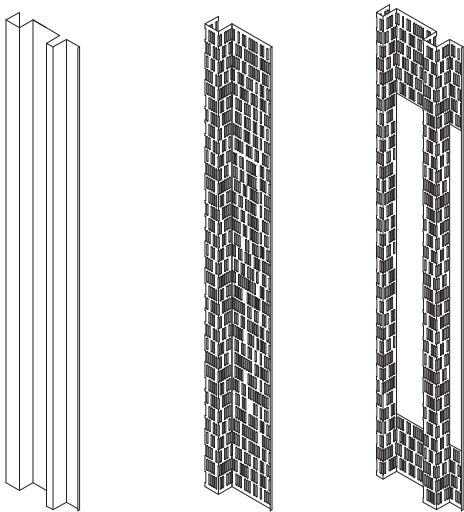

Axonometric views of individual panels

The shimmering cladding of stainless steel sheets surrounds the entire building like a curtain. Depending on the use of the rooms, the facade panels with their irregular profiles are either plain or have a pattern of small, laser-cut slits, which serves to shade the interior.



Additional vertical openings at specific positions in the 2 mm thick sheets allow daylight to enter the rooms through the full-height glazing. This attractive facade design therefore contributes to the sustainable energy concept of the building and at the same time combines the different parts into one coherent unit.

*Stainless steel panels with perforations and larger openings are used in front of the generous areas of glazing in the facade facing the inner courtyard.*



*The exciting alternation of plain, semi-open and vertically slit panels renders the different internal uses legible.*

Photos: H el ene Binet



Photo: H el ene Binet

*The long roadside facade is made up of plain and perforated panels with heights of up to 4.50 m.*

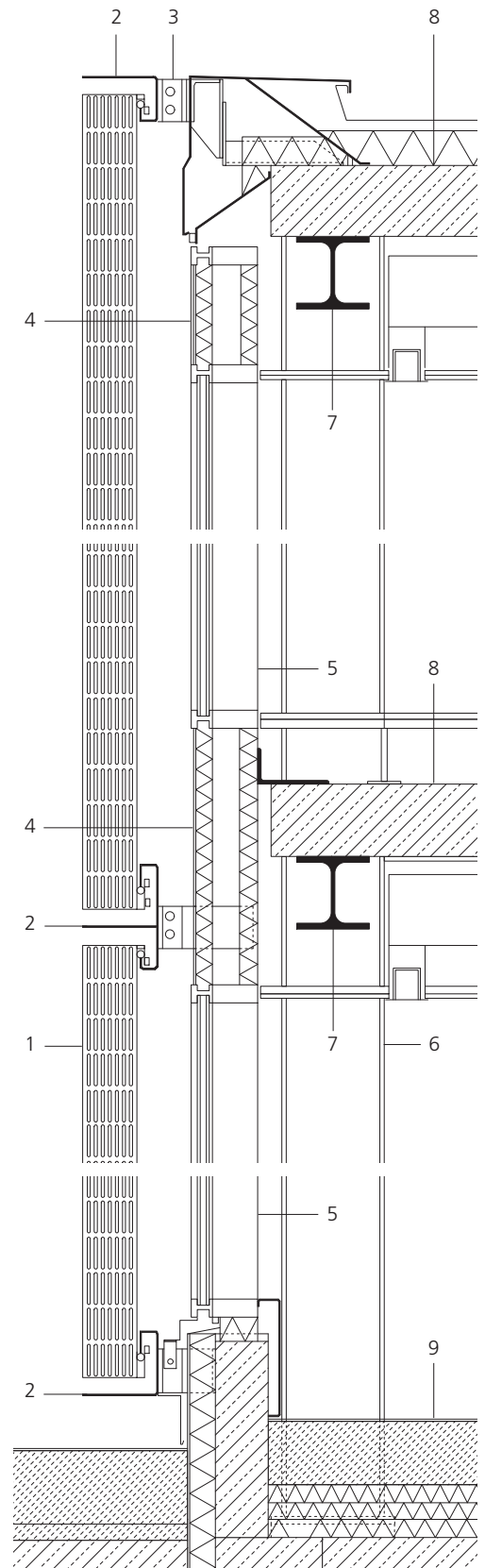

Vertical section, scale 1:20

- 1 Facade panel,  
2 mm stainless steel, EN 1.4301,  
satin-polished finish, profiled,  
laser-cut perforations,  
panel height 4 000–4 500 mm
- 2 Mounting rail, stainless steel
- 3 Support, stainless steel
- 4 Coated sheet aluminium,  
2 layers of 50 mm insulation
- 5 Post-and-rail facade
- 6 Column, HEA 300 steel section
- 7 Beam, HEB 200 steel section
- 8 Floor, 200 mm reinforced concrete
- 9 Industrial flooring on insulation



## Office building in Brussels, Belgium

Client:

Immobilière SEM

Architects and engineers:

Samyn and Partners, Brussels

This office building in Brussels dating from the 1960s needed full refurbishment to bring it up to today's standards. The old, non-insulated, windowed facade has given way to well-insulated timber cladding that reproduces the grid of the loadbearing structure on the exterior. Storey-high, set-back window openings with external bamboo louvre blinds now permit a view of the Royal Park on the other side of the road. A second leaf in the facade design employs narrow stainless steel sections and fixed glass louvres to protect the timber against rain. On the top floor there is additional protection against the weather in the form of an overhanging eaves detail, also in glass and stainless steel.



*Stainless steel's high-strength (EN 1.4301) means it is possible to design an extremely slender structure for the glass facade with sections measuring just 100 × 12 mm.*

*A narrow balcony, protected against wind and rain, has been created between the glass louvres and the windows.*



Photos: Marie-Françoise Plissart (top); Philippe Samyn and Partners/ Quentin Steyaert (bottom)





*The public plaza at road level extends across the basement storey, which is protected against flooding, and ends in impressive steps down to the riverside.*

**Office blocks in Hamburg, Germany**

Client:  
 AUG. PRIEN, Immobilien Gesellschaft für  
 Projektentwicklung mbH, Hamburg  
 Architect:  
 CARSTEN ROTH ARCHITEKT, Hamburg  
 Structural engineers:  
 Wetzels & von Seht, Hamburg

Instead of one block, two striking, separate structures have now closed off the final gap in the quayside development along Altona's waterfront. These identical buildings, not quite parallel with each other, permit a view of the river from the rising ground behind and create a public plaza that links Grosse Elbstrasse with the riverside promenade. The long sides of these eight-storey buildings taper on plan in both directions from the central axis to the gable ends, which have identical designs because of the exposed position between the road and the river. Storey-high window strips and offset "incisions", which form balconies in the second and third storeys, lend structure to the facades. However, the real appeal here is the cladding of titanium-coated stainless steel. The shimmering panels, with their red gold colouring reminiscent of the warm reddish shades of the historic brick warehouses of the port, were specially developed for this project.

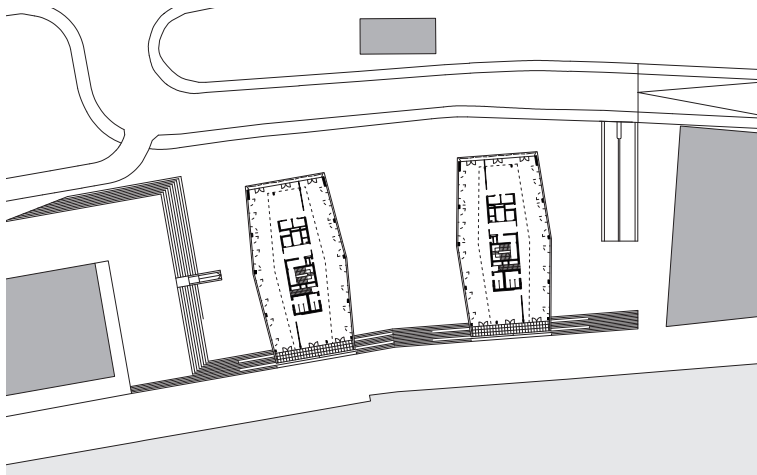

Block plan showing layout of standard floor, scale 1:1500

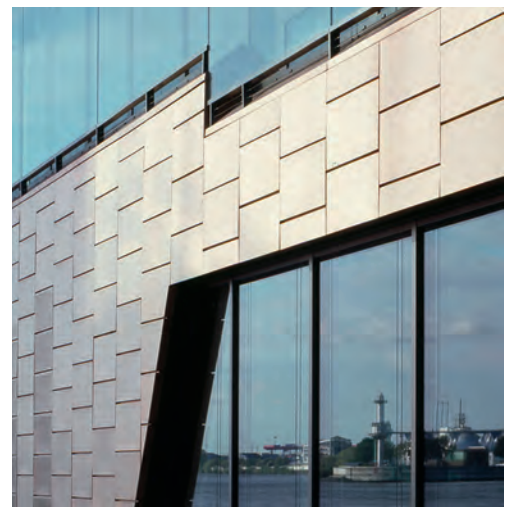



Photos: Klaus Frahm

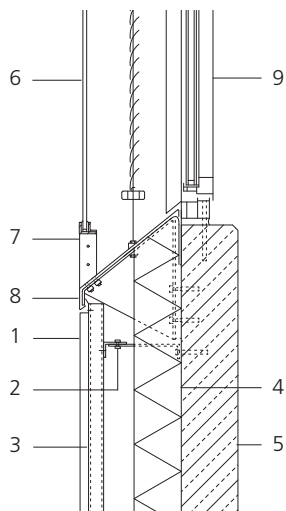

Vertical section, scale 1:20

- 1 Clip-in panel, 0.6 mm stainless steel, EN 1.4404, textured finish, PVD coating
- 2 Fixing, 2 No. angles
- 3 Supporting framework, aluminium T-sections
- 4 Insulation, 125 mm
- 5 Reinforced concrete, 150 mm
- 6 Laminated safety glass, 2 No. 10 mm
- 7 Steel flat, 45 × 12 mm, with stainless steel wires as bird control measure
- 8 Window sill, 1.5 mm stainless steel, EN 1.4404, rolled textured finish, PVD coating
- 9 Window element, lightweight metal frame with solar-control glass, 10 mm laminated safety glass outside, 8 mm toughened safety glass inside

*The appearance of the scale-like building envelope of stainless steel panels with a proprietary coating is broken up by the horizontal window strips and varies depending on the lighting and weather conditions.*



### Fire station in Bruges, France

Client:

La Gironde Fire-Fighting Department

Architects:

Luc Arsène Henry & Alain Triaud Architectes,

Bruges

Structural engineers:

OTH Sud-Ouest, Bordeaux

together all the functional units in the fire station. The colourful edifice, 85 m long and 52 m wide, houses the vehicle bay, sports facilities and accommodation for the fire-fighters. Located at the interface between these three areas is the duty room – the sensitive nerve of the fire station.

Contrasting features dominate the various internal zones: high ceilings and long spans prevail in the vehicle bay and sports hall, cosy intimacy in the fire-fighters' accommodation. The shiny, shimmering facade on all sides only reveals the internal uses by way of the few openings of different sizes and the arrangement of the red-coated steel or

A fast, coordinated response is vital in every incident involving the fire brigade. Therefore, this compact structure near Bordeaux brings

*The long, colourful facades of this block-like structure enclose the fire station's different internal uses.*

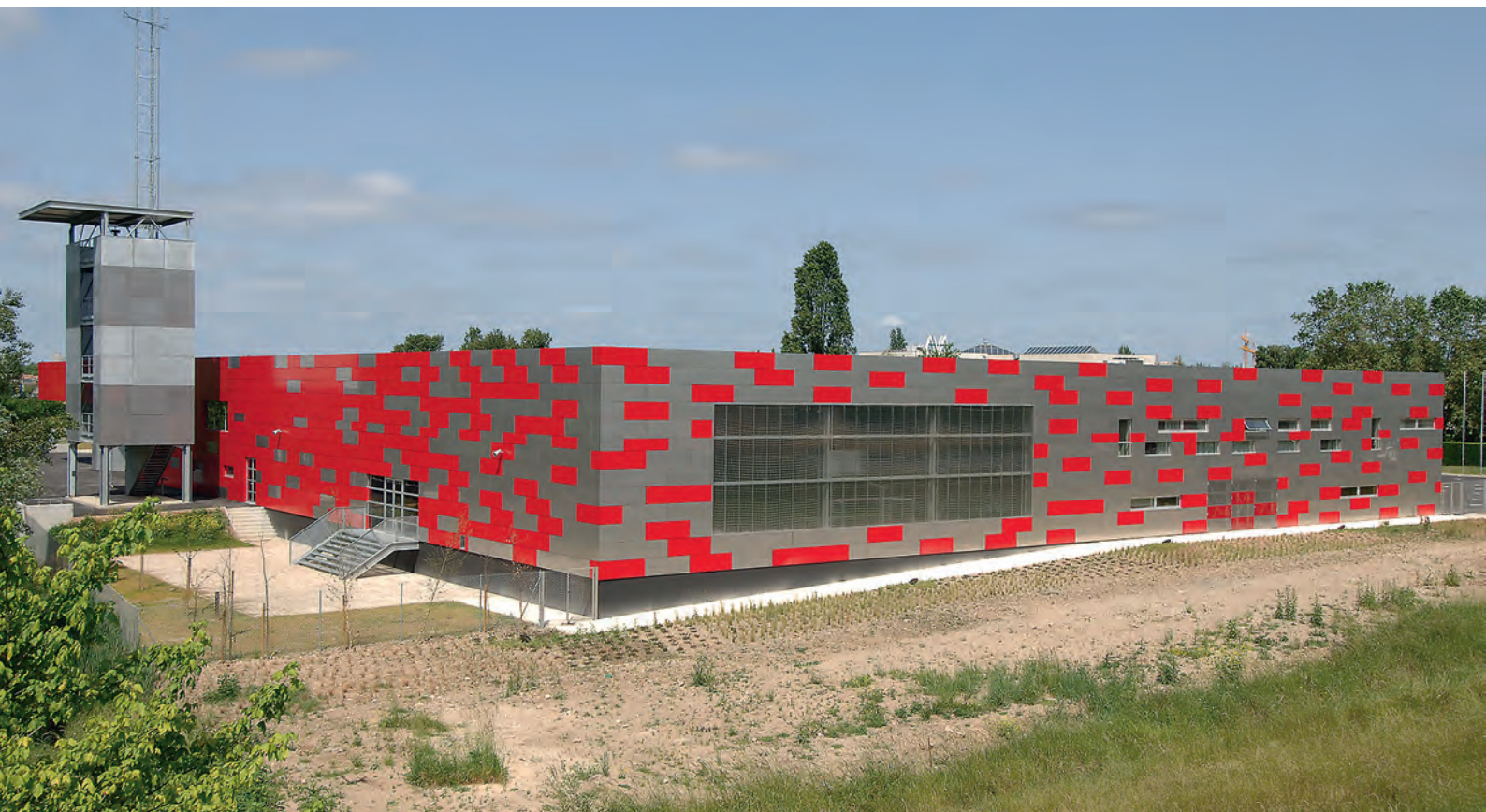

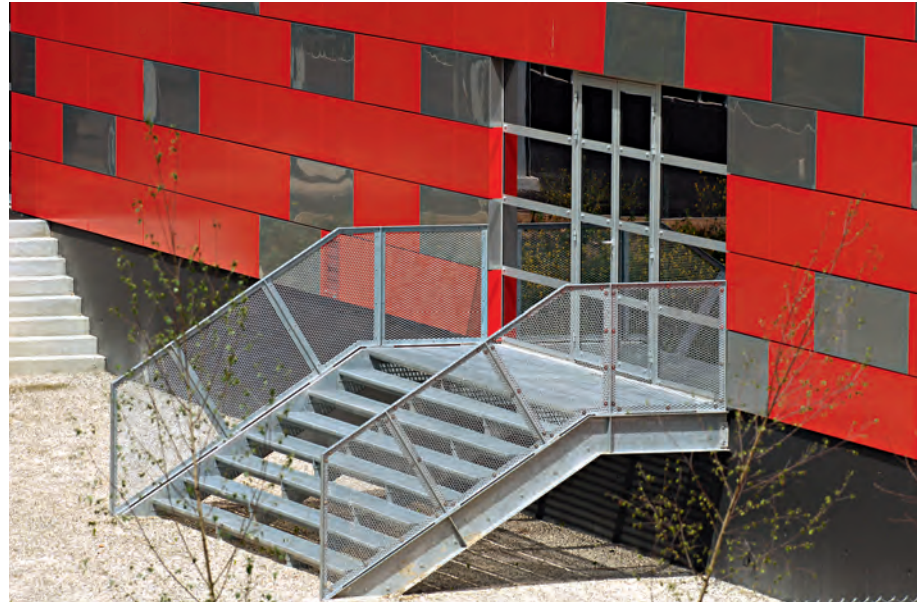
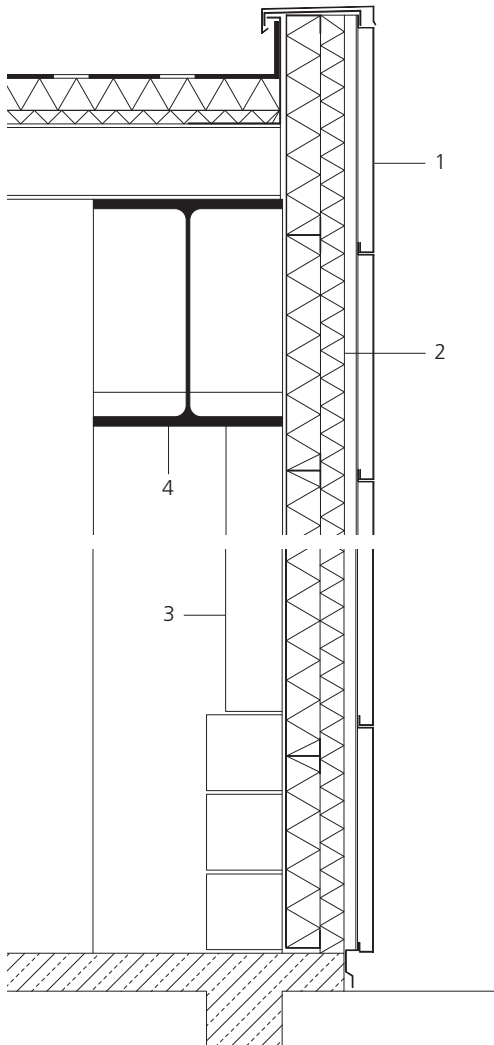

Photos: Frédéric Desmesure

*The satin-polished, lightly reflective stainless steel surfaces between the bright red panels lend the facade a certain depth.*

Vertical section, scale 1:20

- 1 Facade panel, 1800 × 600 mm, 1.5 mm stainless steel, EN 1.4301, satin-polished, or 1.5 mm sheet steel with red coating
- 2 Insulation, 160 mm
- 3 Facade column, galvanised steel
- 4 Main beam, IPN steel section

satin-polished stainless steel panels. For example, red, with its obvious associations, becomes more prevalent around the vehicle bay and the duty room. The offset layout and the irregular colouring give the facade an exciting dynamic.



*This structure, which has only a few openings and is thus reminiscent of an industrial building, gains its unmistakable appearance from the irregular arrangement of the steel panels.*





Photo: Living Architecture

*Sliding windows from floor-to-ceiling and glazed openings in the roof and the floor offer the occupants good views of the surrounding countryside.*

## Holiday home in Thorington, England

Client:

Living Architecture

Architects:

MVRDV, Rotterdam (draft design),  
Mole Architects, Ely (detailed design)

Structural engineers:

Jane Wernick Associates, London

In terms of its form and materials, this building, situated in unspoilt countryside not far from Thorington in the English county of Suffolk, is really quite remarkable. The “Balancing Barn” is one of the holiday homes designed by renowned architects for the non-profit-making organisation “Living Architecture”, whose aim is to ensure the public can experience unusual architecture. Approaching the Balancing Barn from the tree-lined driveway, the building seems

rather small and traditional. But a closer look reveals that this elongated block, 7 m wide and 30 m long, cantilevers an incredible 15 m beyond the ground as it slopes away. The external cladding is in the form of stainless steel shingles which cover the roof and the facades. Even the underside of the cantilevering portion is clad in stainless steel to reflect the surroundings. As a contrast to the metal exterior, the interior is entirely in timber.

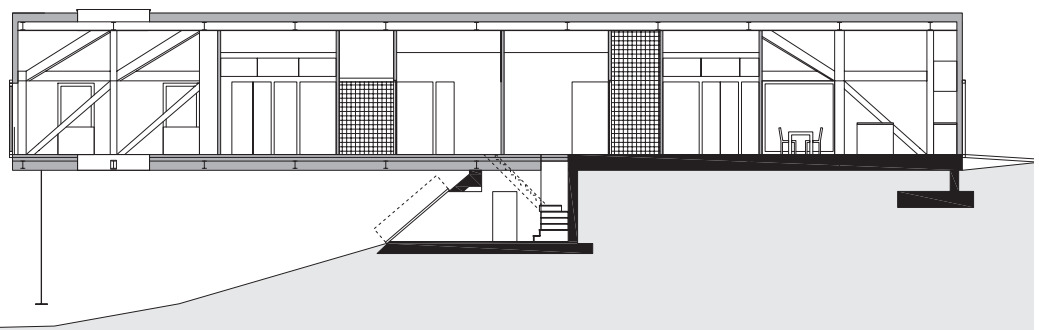

Longitudinal section, scale 1:250

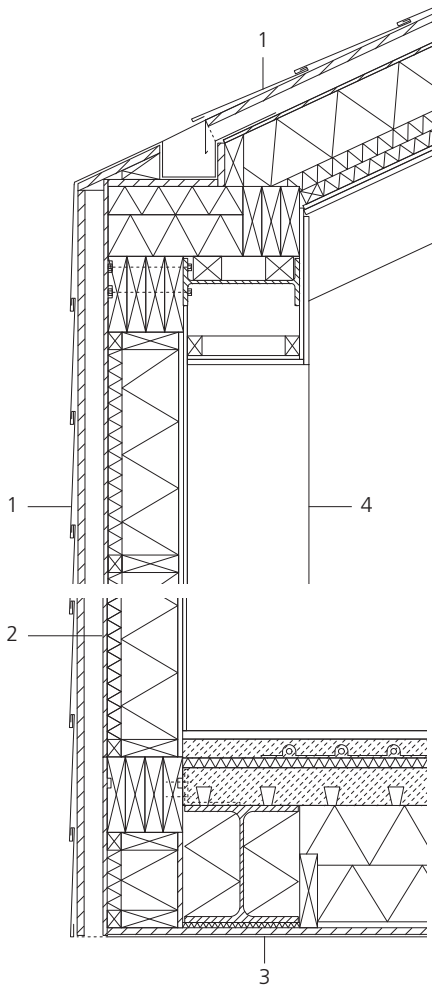

Photos: Edmund Sumner (top); Living Architecture (bottom)

Vertical section, scale 1:20

- 1 Facade/roof shingles,  
0.5 mm stainless steel, EN 1.4401,  
2R finish, on separating membrane and  
wood-based board
- 2 Timber studs with plywood lining
- 3 Soffit,  
0.6 mm stainless steel, EN 1.4401,  
mirror-polished,  
on weather-resistant wood-based board
- 4 Diagonal bracing, steel section

*The cantilevering  
portion of the building  
is counterbalanced by  
the weight of the solid  
ground slab below the  
other half.*





**Archive in Bure, France**

Client:  
EDF  
Architects:  
LAN Architecture, Paris  
Structural engineers:  
Batiserf Ingénierie, Fontaine

French energy group EDF now has a new building near Bure in the Lorraine region in order to store all its archives in one place. The five storeys, with a total floor area of nearly 4 000 m<sup>2</sup>, provide ample space for offices, laboratories and archives. Despite the size of this structure, its new type of facade design enables it to blend into the landscape.

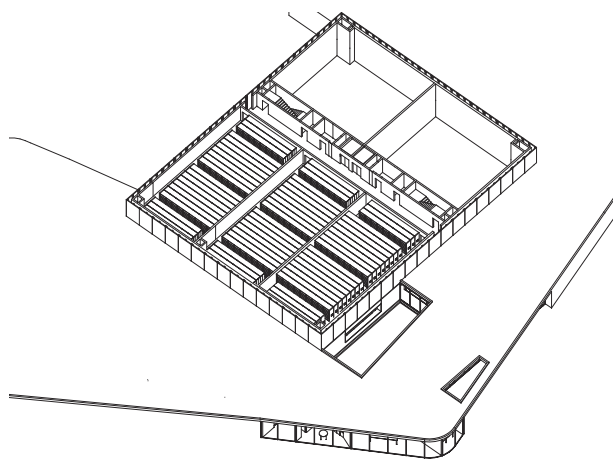

Isometric view of 1<sup>st</sup> floor

*Like a chameleon, the reflective stainless steel discs on the facade of the new archive building adapt to their surroundings.*



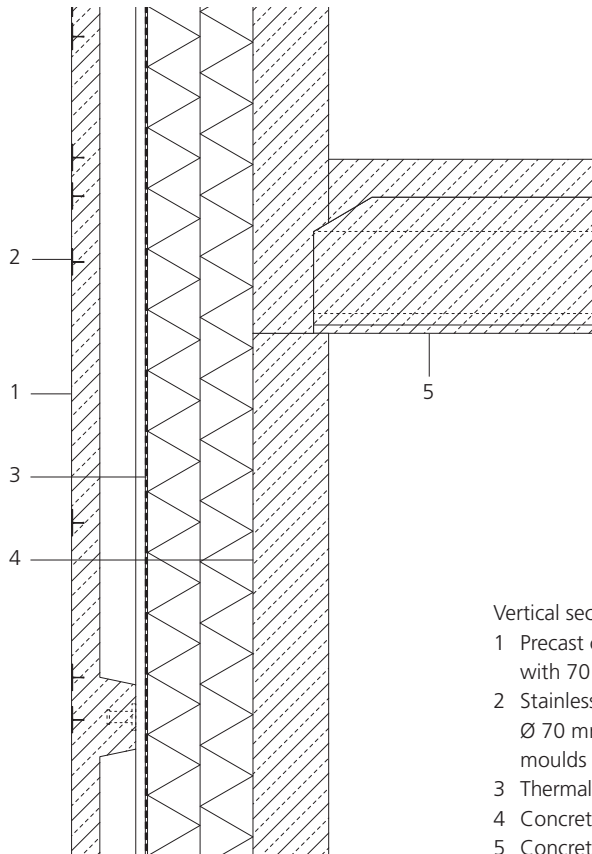

Vertical section, scale 1:20

- 1 Precast concrete element, 80 mm, with 70 mm reinforcing ribs, pigmented
- 2 Stainless steel, 1 mm, EN 1.4404, Ø 70 mm, mirror-polished, laid in the moulds for the precast concrete elements
- 3 Thermal insulation, 300 mm
- 4 Concrete wall, 200 mm
- 5 Concrete ground slab, prestressed



*Full-height glazing on the side facing the inner courtyard ensures plenty of daylight in the offices.*

The offices, on the ground floor and facing north-west, are embedded in the gentle slope and hardly visible from the outside. Above the offices, the window-less concrete cube contains the archives. The precast concrete elements (about 2.30 m wide and more than 15 m high) making up the suspended facade are adorned with more than 100 000 stainless steel discs to lend this solid-looking structure a certain lightness and vitality. The 1 mm thick discs were fixed inside the moulds prior to casting the earth-coloured elements. The mirror-polished surface reflects the colours and lighting of the surroundings, which results in a constantly changing picture.



*The pattern, which extends over all the facades, gradually disperses at the base of the building to create a transition from the earth-coloured concrete to the ground.*

Photos: Julien Lanoo





### Office building in Hamburg, Germany

Client:  
Vineta Erste Projektverwaltungsgesellschaft GmbH  
Architects:  
SEHW Architekten, Hamburg  
Structural engineers:  
Ingenieurbüro Dr. Binnewies, Hamburg

The definite horizontal lines of this new office building for a shipping company in Hamburg's historic port are a response to the slope of the site. On the side facing the River Elbe it abuts an existing building, on the sloping side it dovetails with a small area of planting. The large-format stainless steel facade panels take up the theme of the steel containers so ubiquitous in merchant shipping. They contrast with the existing building and complement it at the same time.

*The small-format historic building and the elegant, almost restrained, new building form a self-evident ensemble with exciting contrasts.*



Photos: Jan-Frederik Waller (top, bottom left); SEHW Architekten (bottom right)

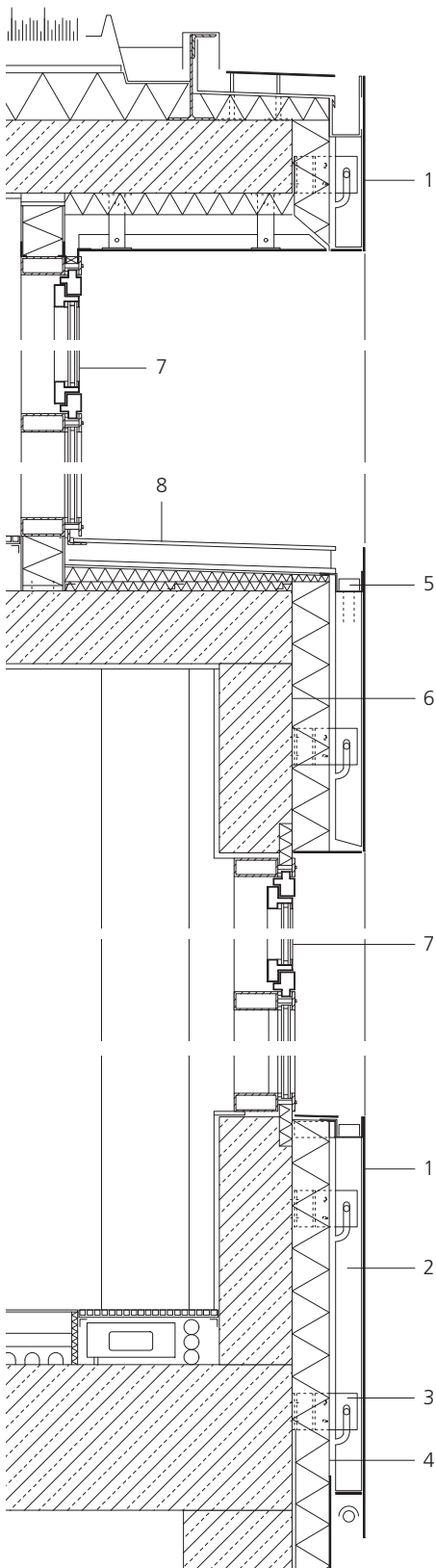

Photo: Jan-Frederik Waller

*The stainless steel panels break up the staggered structure right up to the set-back top storey, which provides a view over the Port of Hamburg and the River Elbe.*

Vertical loadbearing sections were welded to the back of each 3 mm thick, water-jet-cut panel so that they could be mounted on the supporting structure. The flat front faces of the panels, in formats up to 3.00 x 1.40 m, were blasted with ceramic beads. The satin-polished finish of the stainless steel contrasts with the reflective blue solar-control glass to lend the facade a subdued elegance.

Vertical section, scale 1:20

- |   |   |
|---|---|
| 1 Facade panel,<br>3 mm stainless steel, EN 1.4401,<br>ceramic bead-blasted | 4 Insulation, 100 mm                        |
| 2 Loadbearing channel section,<br>45 x 50 x 45 x 2 mm                       | 5 Rainwater gutter                          |
| 3 Support   | 6 Reinforced concrete, 200 mm               |
|   | 7 Glass facade,<br>post-and-rail design     |
|   | 8 Stainless steel sheet, 3 mm,<br>EN 1.4401 |



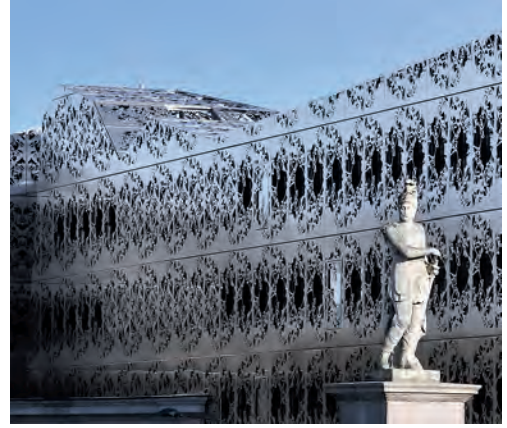

*The delicate ornamentation of and reflections in the stainless steel panels form a charming contrast to the heavyweight entrance structure and the other buildings in this area.*

**Government offices in Nantes, France**

Client:  
 Government of the Loire-Atlantique  
 Department  
 Architects:  
 forma6, Nantes  
 Beatrice Dacher (facade panels)  
 Structural engineers:  
 AREST, Nantes

A respectful co-existence between old and new characterises the new government offices for the Loire-Atlantique Department in Nantes. This long new structure incorporates an old

power station building dating from the 19th century. The solid stone arch forms the entrance zone and a central lobby linking the two wings of the new building. On the side facing the garden, the steel frames of old industrial structures shape the open area and serve as trellises for climbing plants. Two five-storey office wings lead off from both sides of the central stone entrance, following the line of the road.

The grid of the modular office layout is reflected in the striking stainless steel facade. Storey-high panels with laser-cut floral patterns, which allow daylight to penetrate through to the offices beyond, provide a shimmering silvery cloak to the building.

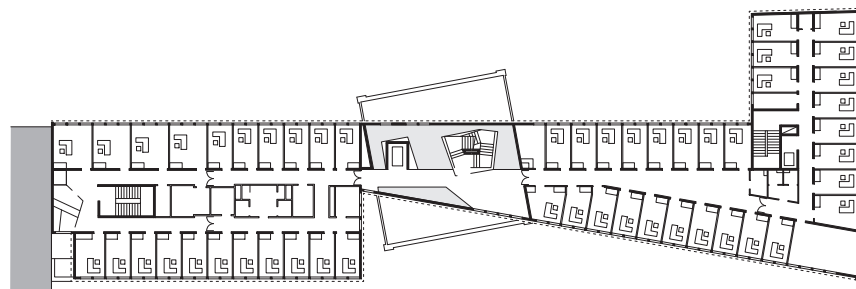

Plan of 3<sup>rd</sup> floor, scale 1:800

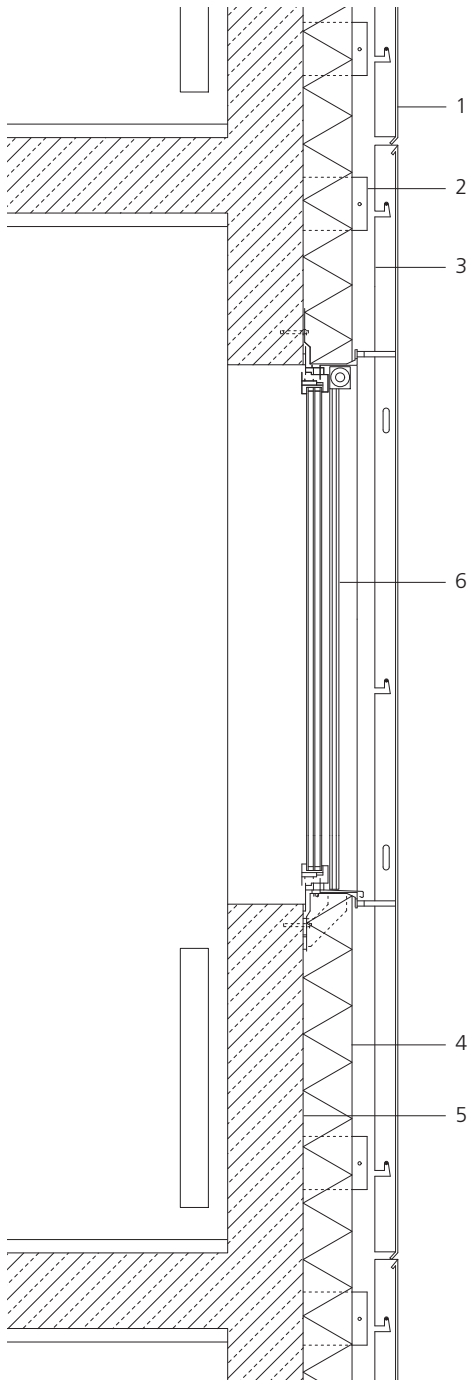

Vertical section, scale 1:20

1 Cladding,  
1,34 × 2,94 m panels,  
2 mm stainless steel, EN 1.4404,  
2K finish,  
with laser-cut perforations

2 Support, stainless steel  
3 Supporting framework  
4 Insulation, 130 mm  
5 Reinforced concrete, 200 mm  
6 Window element with insulating  
glass and external sunshade

Photos: Patrick Miara



*The return in the facade highlights the historic structure and forms a small forecourt in front of the entrance.*



### Computer centre in Garching, Germany

Client:  
Federal State of Bavaria  
Architects:  
Herzog + Partner, Munich  
Structural engineers:  
Herrschmann GmbH & Co. KG, Munich

teaching wing, the institute's offices and a block for high-performance computers and data archives. The latter, known as the "computer cube", is 27.50 m high and 35 m wide and constitutes the heart of this facility. This window-less building with concrete walls is covered on all sides from top to bottom with woven stainless steel. The main reason behind this translucent envelope, with openings amounting to 45 %, is to provide electromagnetic shielding for the building. But a further benefit is the high reflectance value of the fabric, which helps to minimise solar gains.

*Depending on the angle of the light, the chess-board pattern of the concrete wall behind shines through the diaphanous woven stainless steel.*

The Leibniz Supercomputing Centre belonging to the Bavarian Academy of Sciences and Humanities is divided into three parts: a

Photo: Oliver Raupach



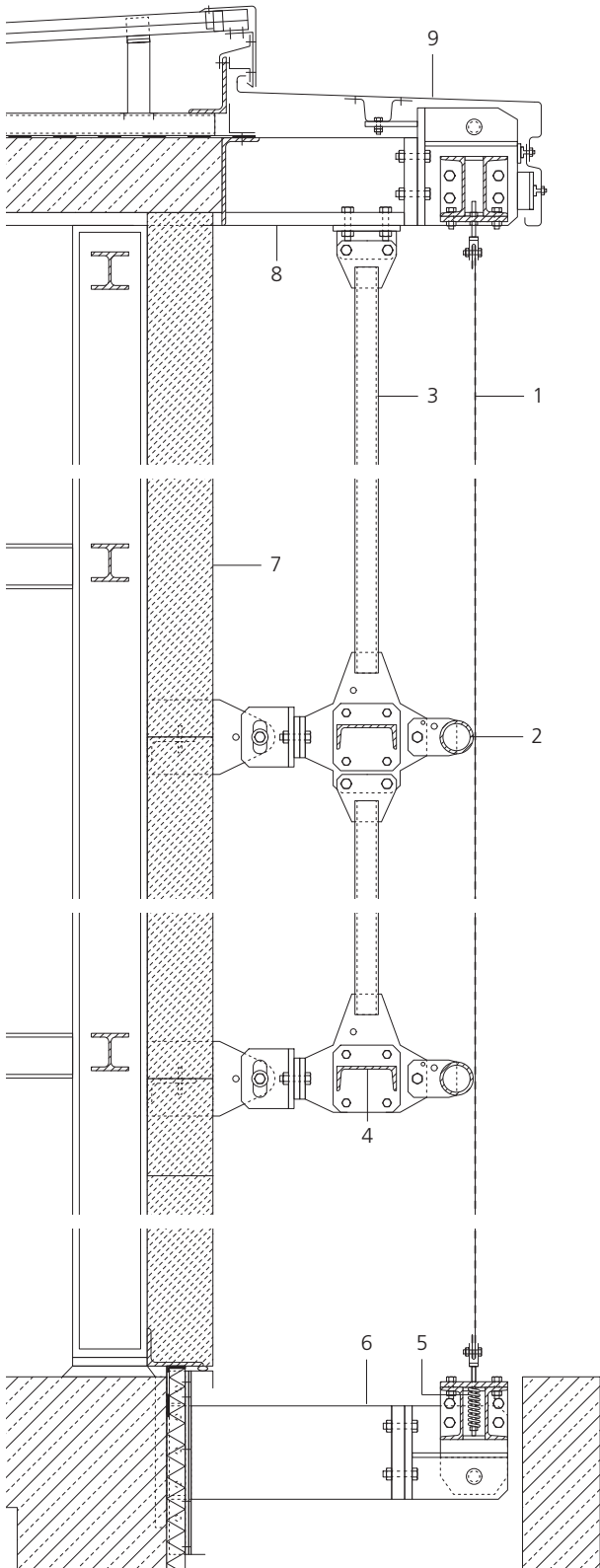

*Groups of vertical round wires in the weave are responsible for the conspicuous pinstripe looks of the facade.*

Vertical section, scale 1:20

- 1 Woven stainless steel, EN 1.4401, composed of flat wires horizontally and round wires vertically, approx. 45 % openings
- 2 Stainless steel tube,  $\varnothing$  88.9 mm
- 3 Stainless steel tube,  $\varnothing$  60.3 mm
- 4 Steel channel section, U 160
- 5 Springs for tensioning fabric
- 6 Steel plate, 250 x 35 mm
- 7 External wall, 175 mm aerated concrete
- 8 T-section welded from 250 x 5 mm steel flats
- 9 Capping, 4 mm stainless steel, EN 1.4571

Photos: Haver & Boecker



**University building in Lausanne,  
Switzerland**

Client:

Canton of Vaud

Architects:

Itten & Brechbühl AG, Lausanne

The campus of the University of Lausanne has been extended to cope with the constantly growing number of students. The Faculty of Geosciences and the Environment as well as the Faculty of Social Sciences and Politics are now housed in a new building on a former factory site which complies with strict sustainability criteria and offers good flexibility for future changes of use.

Four glazed atria in the 148 m long, 48 m wide building serve as communal spaces and ensure ample daylight in the interior. The exterior reveals nothing of the complex inner workings with their lecture theatres and seminar rooms, library, laboratories and offices. A facade of prefabricated glass and stainless steel elements surrounds the five-storey block.

All the storey-high facade elements were fully factory-produced, transported to the site and mounted on the loadbearing structure with the help of adjustable anchorages. The lively appearance of the facade is due to the irregular arrangement of two different types of element: glazed, 2.50 m wide elements with integral sunshades alternate with storey-high metal elements covering half the external wall.

*Silvery, reflective facade elements ensure a unique appearance for this long building.*



The mirror-polished stainless steel sheets have a three-dimensional shape, which results in fragmented reflections of the surroundings. At the same time, the embossed structure scatters the incoming light and reduces glare.



Photos: Thomas Jantscher

*The facade elements give rise to a changing play of light and colours.*

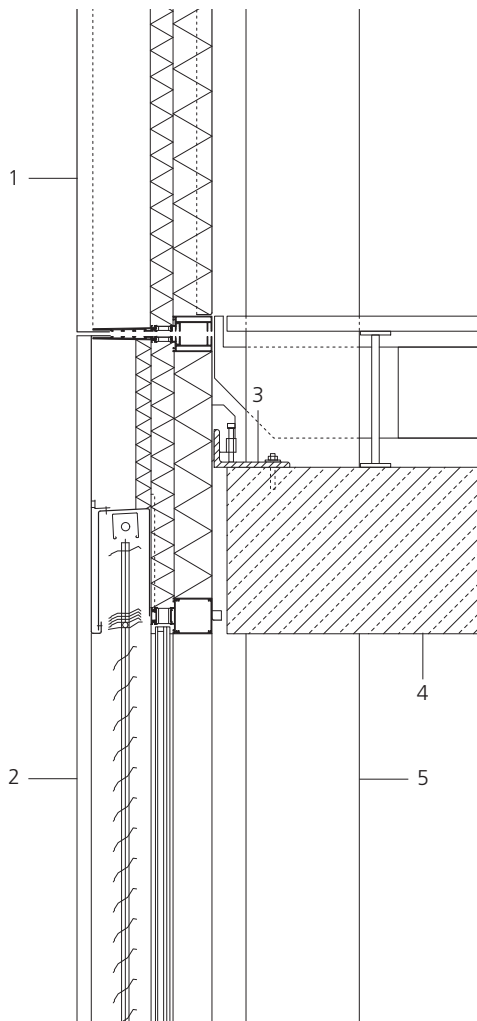

Vertical section, scale 1:20

- 1 Sheet metal facade element, 2 mm stainless steel, EN 1.4301, mirror-polished, embossed 190 mm cavity
- 2 Glazed facade element, external sunshade insulating glass, 6 mm toughened safety glass + 2 No. 8 mm laminated safety glass, sheet metal fascia at top
- 3 Steel angle, 220 × 110 mm
- 4 Reinforced concrete floor, 440 mm
- 5 Reinforced concrete column



*Random components in the computer-controlled pressing process result in every stainless steel sheet having a unique pattern.*



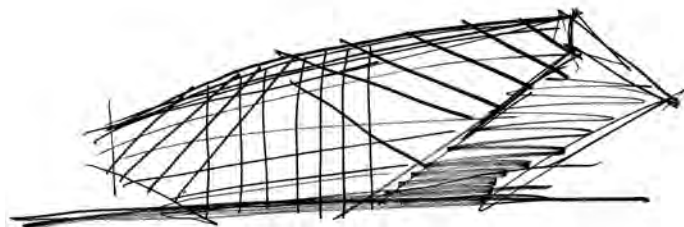

### Office building in Madrid, Spain

Client:

Bouygues Inmobiliaria, Madrid

Architect:

Rafael de La-Hoz Castanys, Madrid

Structural engineers:

PONDIO Ingenieros, Madrid

*The expressive design of this office building is prominent, even from a distance.*

An unusual office building stands out on the “Campo de las Naciones” in Madrid as part of the Cristalia Business Park. This is the prestigious headquarters of an insurance company, with 10 000 m<sup>2</sup> of space for offices spread over seven floors. In order to keep the “footprint” of the building as small as

possible, both gable facades are raised clear of the ground so the surrounding surface extends well below the building. The ensuing inclined surfaces within the building in the two lowest storeys are used for a large auditorium and a reception area for customers.





Photos: Duccio Malagamba



*The stainless steel-clad facade structure of horizontal, vertical and diagonal members is used on all sides of the glazed building.*

The constructional consequences of designing a building with this form are apparent in the broad diagonal “ties” in the facade. These diagonal members in reinforced concrete pass in front of the storey-high glazing between the cantilevering floor slabs and, like the rest of the facade, are clad in stainless steel panels. Reflections in the bright surface of the 1.5 mm thick sheets and the depth of the facade structure, with the ensuing shadows, emphasize the architect’s ideas and lend the facade a graphic character.

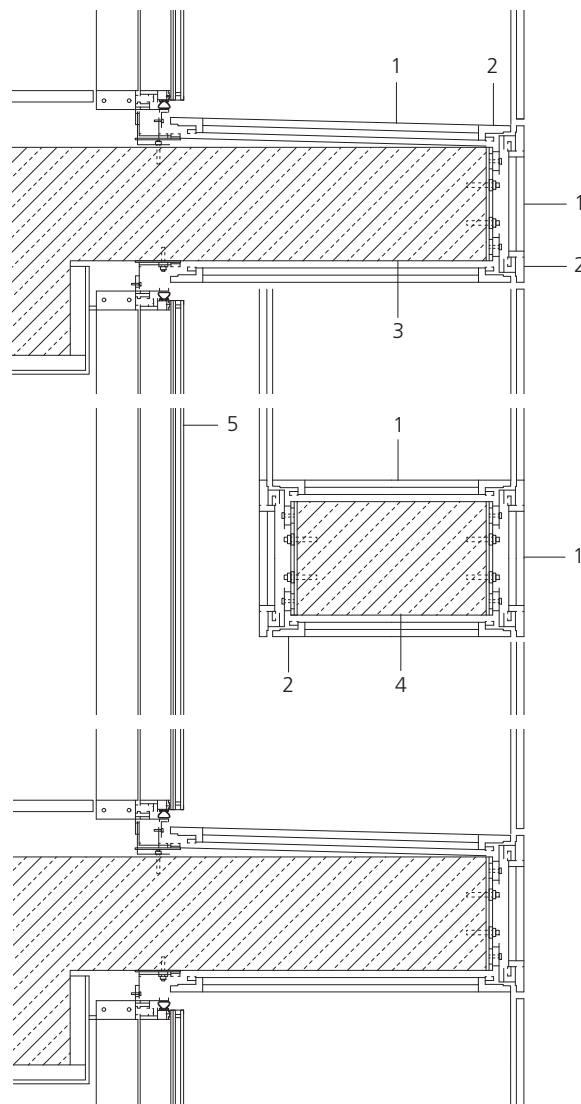

Vertical section, scale 1:20

- 1 Cladding,  
1.5 mm stainless steel, EN 1.4401,  
2B finish,  
on laminated backing board
- 2 Mounting rail
- 3 Cantilevering reinforced concrete  
floor slab
- 4 Diagonal reinforced concrete “tie”
- 5 Glazing





*The congress centre with its facade of stainless steel louvres rises majestically above road, rail and water.*

### Congress centre in Stockholm, Sweden

Client:

Jarl Asset Management, Stockholm

Architects:

White Arkitekter, Stockholm

Structural engineers:

ELU Konsult AB, Stockholm

A new congress centre has been built in the heart of Stockholm directly alongside the main railway station. The three-part “Stockholm Waterfront” complex consists of a congress building for about 3 000 delegates, an office building and a 400-room hotel linked directly to the congress centre. The multi-functional conference halls and the remarkable way the structure cantilevers over the railway station enabled the designers to implement the diverse facilities on a triangular site bounded on all sides by road, rail and water. This new development functions as a link between the historic centre and the aspiring business quarter between Vasagatan and Kungsholmen. Its spectacular stainless steel facade constitutes a new, highly visible landmark on the Riddarfjärden, an arm of Lake Mälaren.

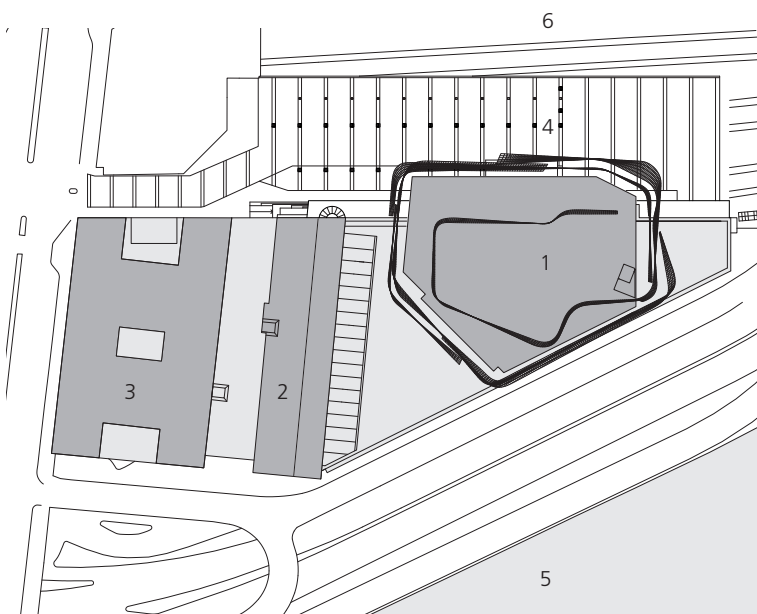

Block plan, scale 1:2000

- 1 Congress centre
- 2 Hotel
- 3 Office building
- 4 Forecourt
- 5 Riddarfjärden
- 6 Railway station

The suspended facade to the large congress hall is made up of more than 3 500 stainless steel louvres. These Z-sections of duplex steel, 3–16 m long, are attached clear of the building at different angles. The ensuing dynamic wave effect fulfils more than just an architectural vision. The positioning of these fixed louvres reduces solar gains in summer and during the winter allows sunlight to penetrate and provide passive heating, thus contributing to the building's comprehensive energy and sustainability concept.

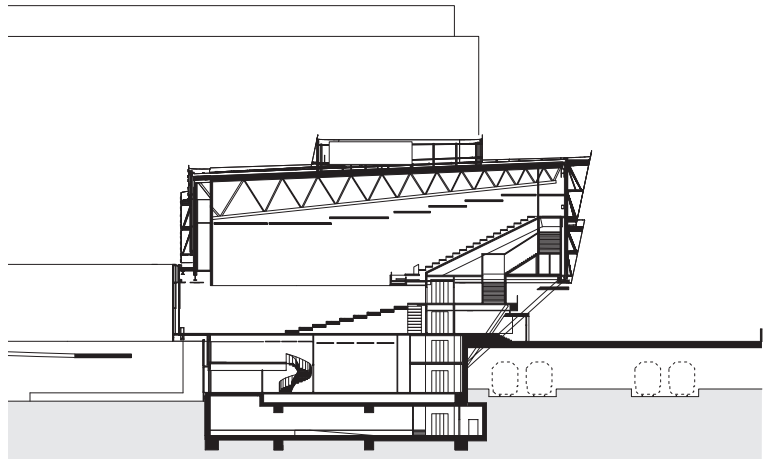

Section through congress building, scale 1:1 000

*The play of light and shadows on the shimmering satin stainless steel emphasizes the flowing forms of the cladding.*

Photos: Wojtek Gurak

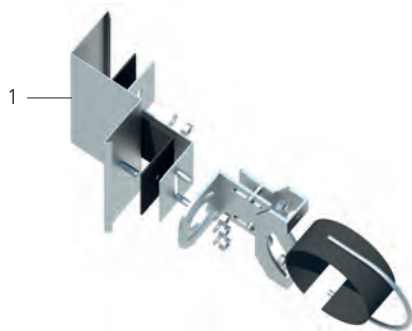
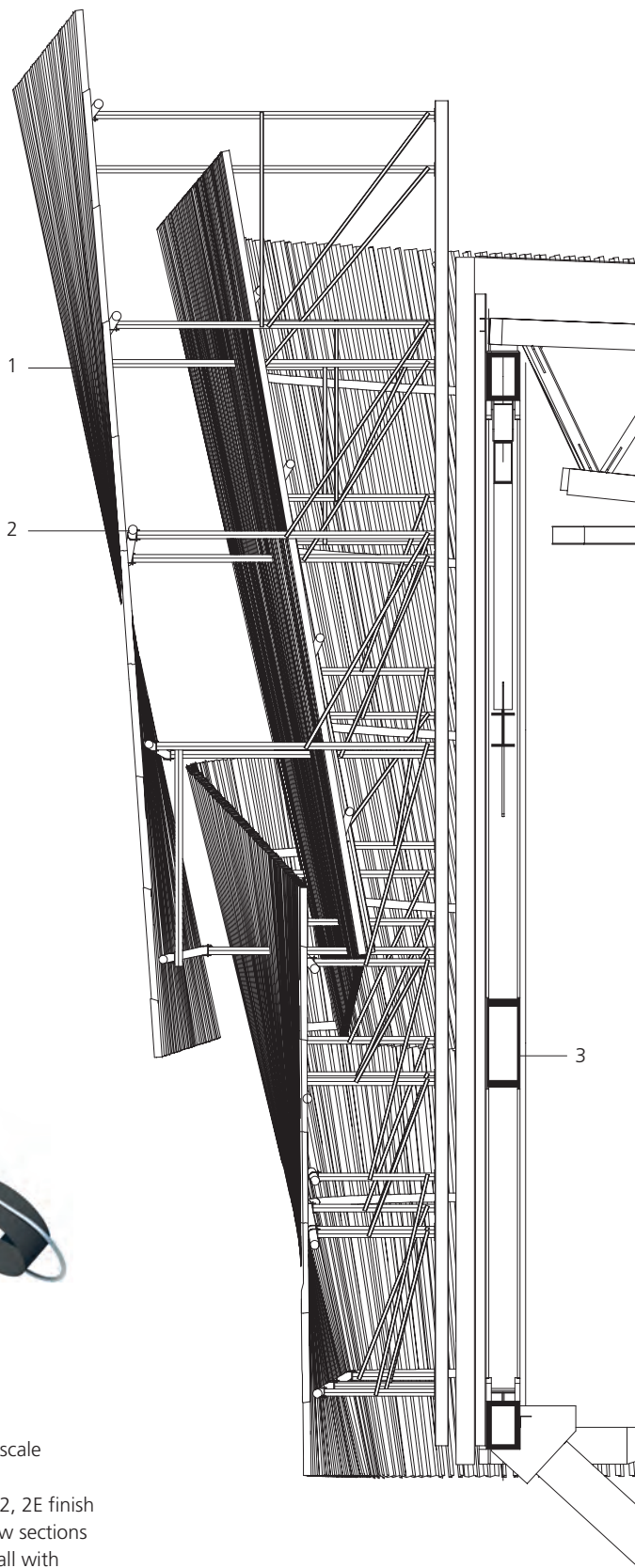





Photo: Wojtek Gurak

*Like a huge canopy, the congress hall cantilevers over the forecourt and main entrance to the congress centre.*



Section through facade, scale 1:100,  
isometric view of fixing detail, not to scale

- 1 Facade louvres,  
Z-section, stainless steel, EN 1.4462, 2E finish
- 2 Supporting structure of steel hollow sections
- 3 Structural steelwork to congress hall with suspended facade (enclosing walls)





ISBN 978-2-87997-372-2