

Building Envelopes in Stainless Steel

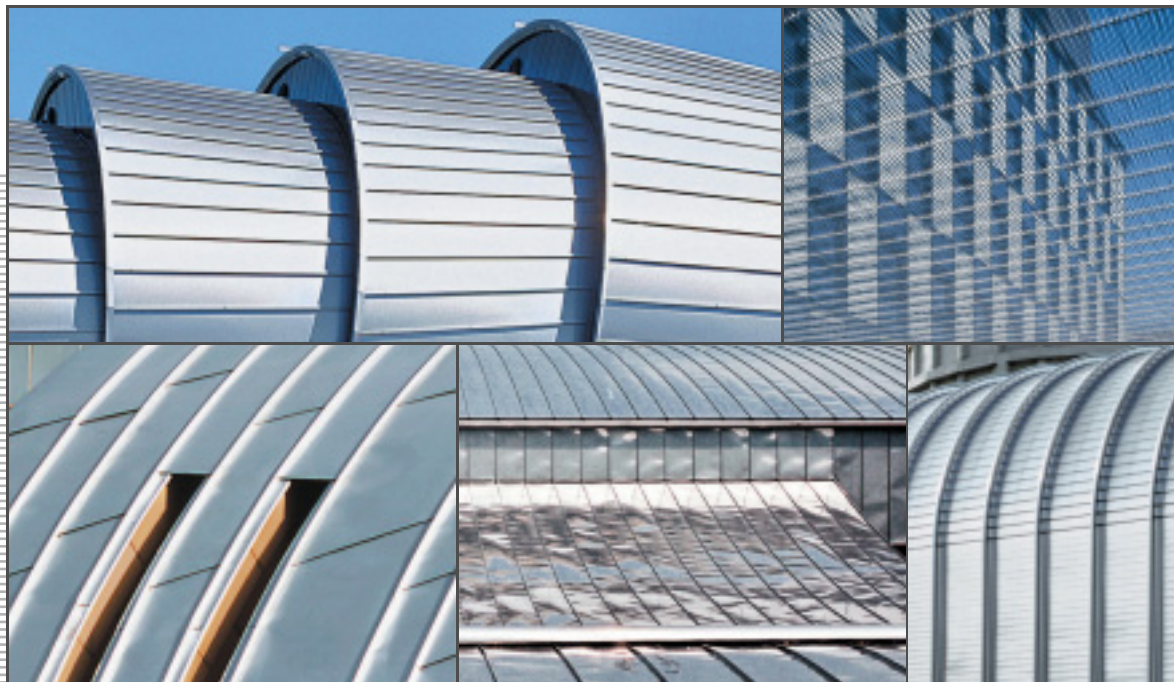

Euro Inox

Euro Inox is the European market development association for stainless steel.

The members of Euro Inox include:

- European stainless steel producers
- National stainless steel development associations
- Development associations of the alloying element industries.

A prime objective of Euro Inox is to create awareness of the unique properties of stainless steels and to further their use in existing applications and in new markets. To assist this purpose, Euro Inox organises conferences and seminars, and issues guidance in printed form and electronic format, to enable architects, designers, specifiers, fabricators, and end users, to become more familiar with the material. Euro Inox also supports technical and market research.

Full Members

Acerinox,

www.acerinox.es

Outokumpu,

www.outokumpu.com

ThyssenKrupp Acciai Speciali Terni,

www.acciaiterni.com

ThyssenKrupp Nirosta,

www.nirosta.de

Ugine & ALZ Belgium

Ugine & ALZ France

Groupe Arcelor, www.ugine-alz.com

Associate Members

Acroni,

www.acroni.si

British Stainless Steel Association (BSSA),

www.bssa.org.uk

Cedinox,

www.cedinox.es

Centro Inox,

www.centroinox.it

Informationsstelle Edelstahl Rostfrei,

www.edelstahl-rostfrei.de

Informationsstelle für nichtrostende Stähle

SWISS INOX, www.swissinox.ch

Institut de Développement de l'Inox (I.D.-Inox),

www.idinox.com

International Chromium Development Association

(ICDA), www.chromium-asoc.com

International Molybdenum Association (IMOA),

www.imoa.info

Nickel Institute,

www.nickelinstitute.org

Polska Unia Dystrybutorów Stali (PUDS),

www.puds.com.pl

Building Envelopes in Stainless Steel
 First edition 2004 (Building Series, Vol. 6)
 ISBN 2-87997-085-7
 © Euro Inox 2004

Dutch version	ISBN 2-87997-111-X
Finnish version	ISBN 2-87997-112-8
French version	ISBN 2-87997-107-1
German version	ISBN 2-87997-110-1
Italian version	ISBN 2-87997-108-X
Polish version	ISBN 2-87997-114-4
Spanish version	ISBN 2-87997-109-8
Swedish version	ISBN 2-87997-113-6

Editor

Euro Inox
 Registered office:
 241 route d'Arlon
 1150 Luxembourg, Grand Duchy of Luxembourg
 Phone +352 26 10 30 50 Fax +352 26 10 30 51
 Executive office:
 Diamant Building, Bd. A. Reyers 80,
 1030 Brussels, Belgium
 Phone +32 2 706 82 67 Fax +32 2 706 82 69
 E-mail info@euro-inox.org
 Internet www.euro-inox.org

Author

Martina Helzel, circa drei, Munich, Germany
 (content, layout, text)
 Ingrid Taylor, Munich, Germany (translation)

Content

Introduction	2
Residential	4
Research and Education	6
Administration and Commercial	12
Sports Facilities	20
Technical Installations	22

Disclaimer

Euro Inox has made every effort to ensure that the information presented in this document is technically correct. However, the reader is advised that the material contained herein is for general information purposes only. Euro Inox, its members, staff, and consultants, specifically disclaim any liability or responsibility for loss, damage, or injury, resulting from the use of the information contained in this publication.

Cover photos:

Rob 't Hart, Rotterdam (top left),
 Roland Halbe, Stuttgart (top right),
 Martine Hamilton Knight/BDP, Manchester (bottom left),
 Jean-Luc Deru, DAYLIGHT s.p.r.l., Liège (bottom middle),
 Fulvio Orsenigo, Venice (bottom right)

Introduction

The building envelope separates inside from outside and also acts as an interface between the building and the urban environment. Its most important functions are to protect against climatic influences (cold, heat, rain and wind), define volume and create a private sphere. As part of this envelope, the façade is both the public face of a building and also a component in the overall urban scene. Modernism called for the outer appearance of a structure to also reflect the building's function. This, coupled with the increasing autonomy of façade and support structure (curtain wall) and growing demands for flexibility, led to greater concentration on the outer surfaces. Correspondingly, the materials used and their properties have also gained greater significance. The colour and texture of the materials chosen play a critical role in a building's visual appearance.

Modern profile styles and connecting techniques facilitate the use of stainless steel sheet even when working with longer strip lengths and complex geometries.

Photos: Jean-Luc Deru, DAYLIGHT s.p.r.l., Liège (top), Andre Kiskan, Vienna (bottom)



Reflections of the surrounding environment and varying light moods change the visual appearance of the stainless steel envelope.

The examples presented in this brochure show stainless steel used in the building envelope, on both façades and roofs. They illustrate a range of construction types, in which stainless steel sheet is folded or welded together to form a watertight layer. In many cases, because of the high corrosion resistance of stainless steel, no ventilation zone is needed. Stainless steel gutters integrated into the surface of the roof carry away the rainwater without presenting any disturbance to the overall visual effect. In a building envelope composed of several layers, an outer skin of stainless steel in the form of perforated sheet or mesh has more than just a decorative role. Placed in front of extensively glazed walls, it can also play a part in solar shading and light deflection.





A range of alloys are available to meet the corrosion-resistance requirements of differing locations – the example here is of a coastal environment.

Although stainless steel has a modern, technical image, its visual appearance is in fact more neutral. Its surfaces, varying in smoothness according to the type of finish (mill finish, polished, blasted, patterned, electropolished, etc.), reflect light and colour, thus ensuring a harmony with the immediate environment.

Like other materials, metals that were once used mainly in the construction of industrial buildings have now found wider application in architecture and are being used even in very prestigious projects. Technology is advancing fast, and new possibilities are opening up all the time. Our expectations as regards visual appearance are being challenged. A spirit of architectural experimentation further underpins this trend. Stainless steel with its superb material characteristics is playing an important role here, and this is set to continue.

Stainless steel mesh or perforated sheet used to reduce solar gain. The visual link with the outside is maintained, but only diffuse light is allowed to penetrate into the interior.

Photos: Rob 't Hart, Rotterdam (top), Roland Halbe, Stuttgart (bottom left), Florian Holzherr, Munich (bottom right)



Residential



The south-facing stainless steel roofs and façades seem to fill like sails in the wind.

Apartment blocks in 's-Hertogenbosch, Netherlands

Client:
Credo Integrale Planontwikkeling B.V.,
Oosterbeek
Architect:
Building Design Partnership Ltd, Manchester

This distinctive complex is located at the heart of a new residential district, built on an old industrial site close to the historical centre of 's-Hertogenbosch. Spaced along one side of an artificial water course are two different styles of apartment block, their shape and orientation determined by the prevailing wind and light conditions.

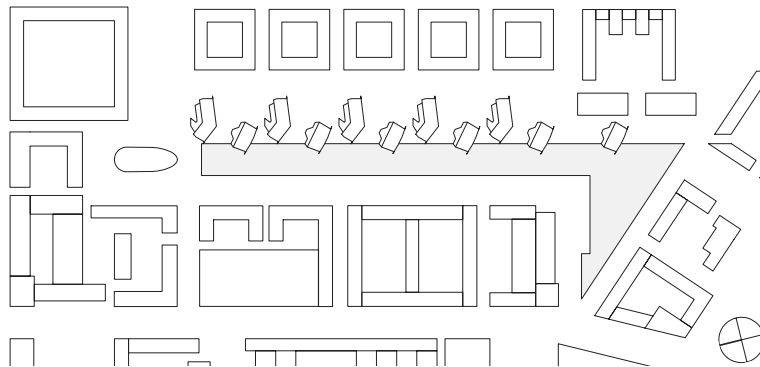

Site plan
scale 1:7500

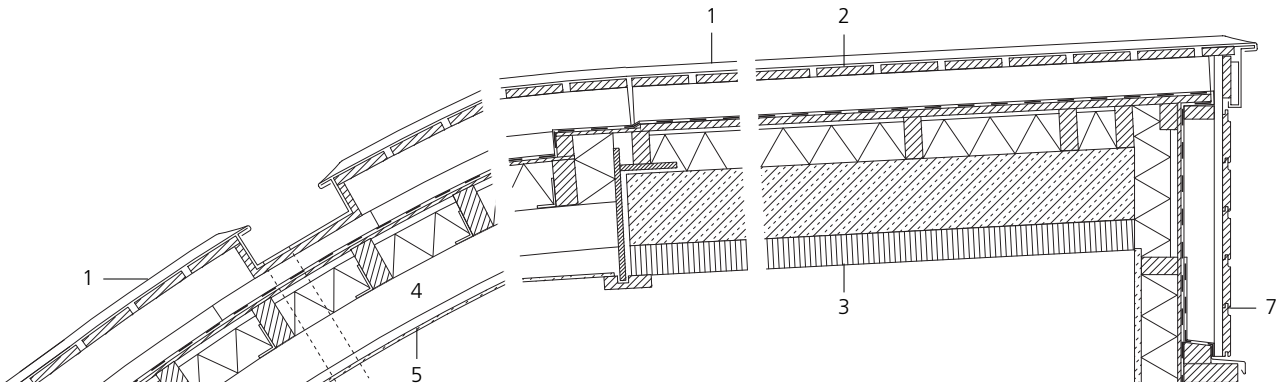

Section scale 1:20

- | | |
|---|--|
| 1 1 mm stainless steel sheet, grade 1.4401, 2B finish, 20 mm standing seam | 4 120 mm rafter |
| 2 22 mm timber decking
46/96 mm glued laminated girder
sealing layer
9 mm plywood
100 mm mineral wool | 5 9 mm gypsum fibreboard on 22 mm battens |
| 3 190 mm reinforced concrete
80 mm glued laminated timber | 6 15 mm gypsum fibreboard vapour barrier
46/121 mm post-and-beam construction
120 mm mineral wool thermal insulation
9 mm plywood |
| | 7 18 mm Oregon pine matchboard |



Glass-fronted winter gardens on the timber- or tile-clad north sides give sheltered access to the apartments. The large standing-seam roofs and façades face south and southeast, away from the prevailing winds. The curved shape reduces wind resistance – a feature that also minimises wind turbulence in the

gardens between the individual blocks. On warm days, the roof terraces and the balconies on the curved stainless steel fronts can be utilised as additional living space. Photovoltaic cells are mounted on wind deflectors near the roof ridge.

The rainwater gutters are integrated into the broad expanse of stainless steel that stretches from the roof down to the ground floor. Varying widths of stainless steel sheet are fitted together in this standing seam cladding.

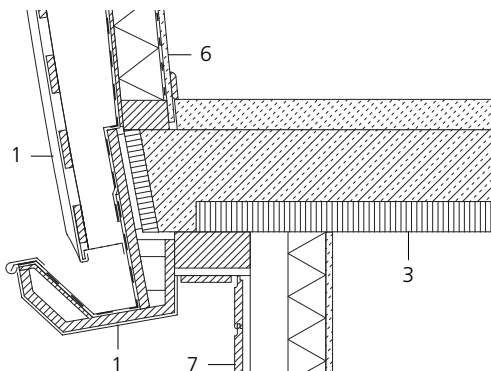

Photos:
Martine Hamilton Knight/
BDP, Manchester

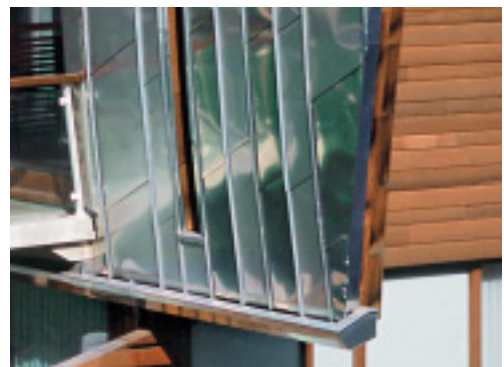

Research and Education

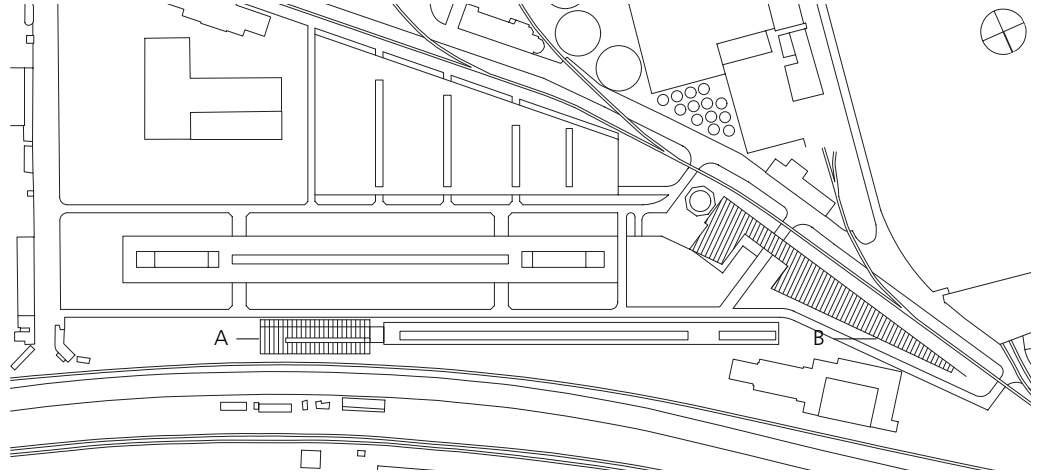

Site plan
scale 1:5000
A 'Incubatore'
B 'Auriga'

Technology park in Venice, Italy

Client:
VEGA, Venice
Architects:
Wilhelm Holzbauer, Vienna
Paolo Piva, Venice
Roberto Sordina, Venice

The decline in heavy industry left its mark on the commercial port of Venice. Now the local authorities have launched an initiative to reinvigorate the old port, which is located in the lagoon close to the city. Disused industrial sites are to be developed for new functions and high-tech firms attracted to the area.

Disused areas of the old commercial port of Venice, located close by the city centre, are being redeveloped as part of a general reinvigoration plan.

Photo: Fulvio Orsenigo, Venice





Photos: Fulvio Orsenigo, Venice

The 'Auriga' building, located at the tip of the triangular site, houses offices, laboratories, a reception area, bar and restaurant.

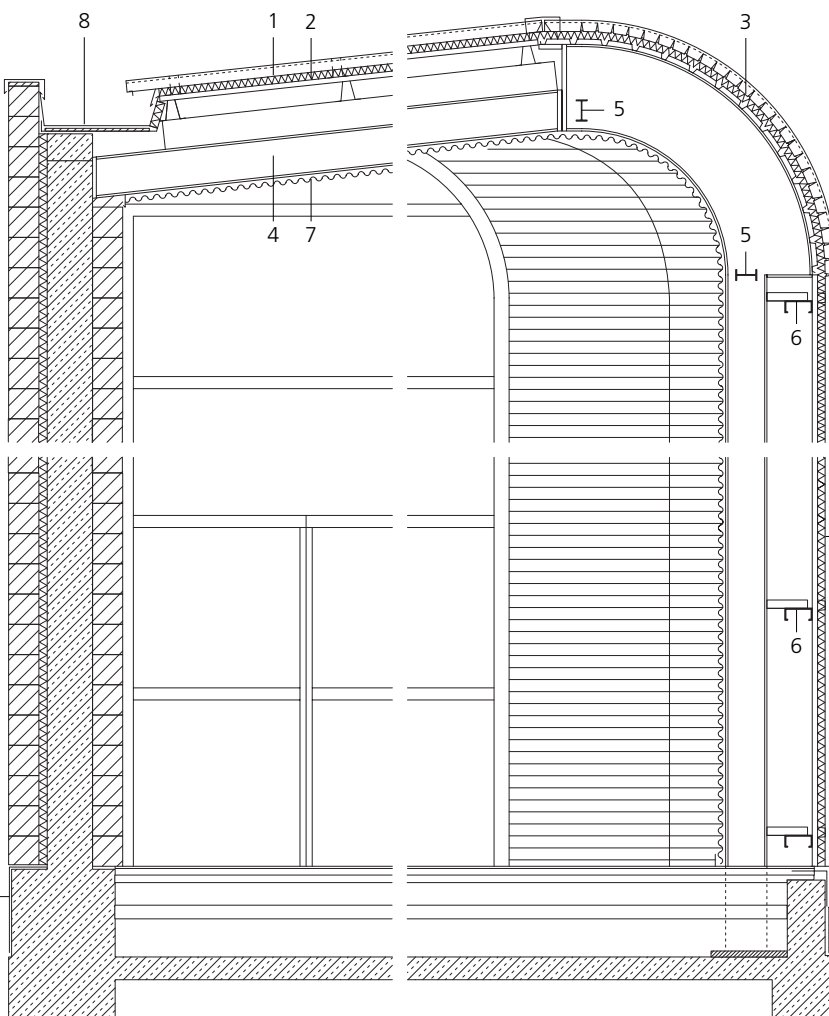

Section scale 1:50

- 1 0.6 mm stainless steel sheet, grade 1.4401, 75 mm standing seam
- 2 Deck:
50 mm glass wool thermal insulation
35 mm galvanised steel trapezoid sheet
omega-profile spacer sheet
steel I-beam 160 mm deep
- 3 Curved stainless steel sheet
r=1670 mm
- 4 Steel I-beam 240 mm deep
- 5 Steel I-beam 140 mm deep
- 6 80/180 mm steel channel section
- 7 Inner lining
40 mm corrugated sheet
- 8 Gutter, stainless steel sheet

A centre for research and technology is being built in four phases on a disused industrial site from the early 20th century. Rising up above the site is a previously renovated cooling tower, which both signposts and stands watch over the new development on this industrial heritage site. The extensive use of stainless steel on façades and roof surfaces underlines the modern image of the technology centre and fulfils the exacting requirements of the coastal location in terms of corrosion resistance. Erected on the tip of the triangular plot, on the foundations of

a former factory, is the ‘Auriga’ building. In one half of the two-part structure is the reception area with bar and restaurant, and in the other, the offices and laboratories. The stainless steel cladding curves round at the top to continue over the roof. It is made up of 50 cm wide, profiled sheets, which were cold-formed on site from strip steel using a mobile profiling machine. The finished strips are fixed unobtrusively onto the deck at the standing seams, thus avoiding the need to drill holes in the panels.

The stainless steel cladding enhances the modern, high-tech look of the building.





A former warehouse was converted into an exhibition and events venue.

Photos: Fulvio Orsenigo, Venice

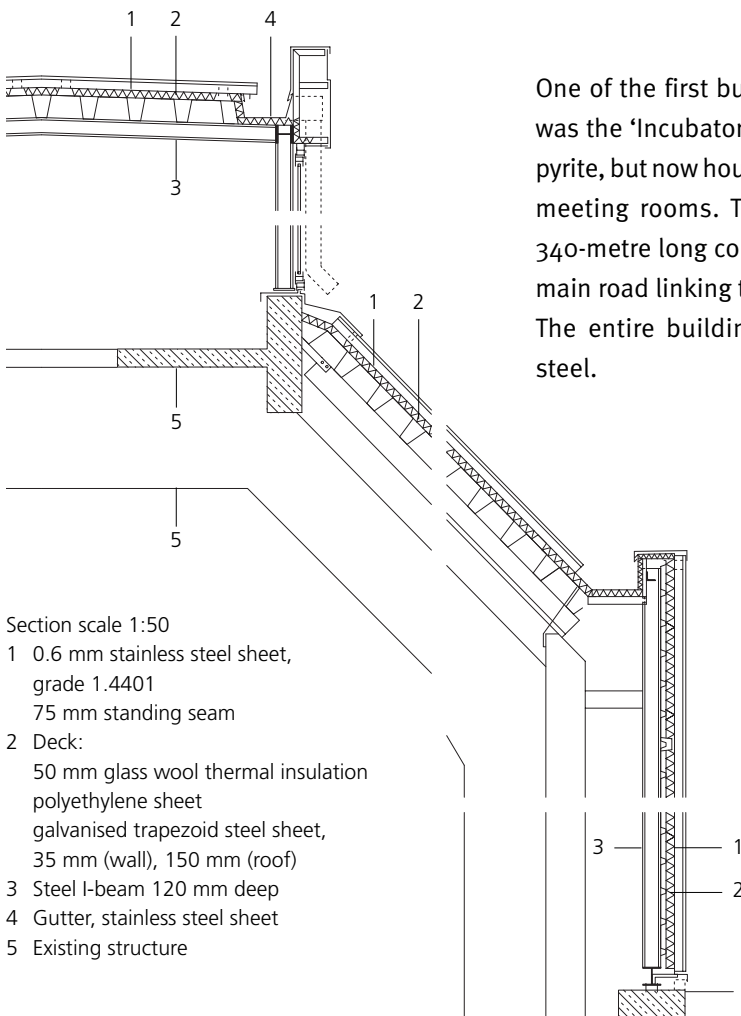

One of the first buildings to be refurbished was the 'Incubatore', formerly used to store pyrite, but now housing exhibition space and meeting rooms. The 'Incubatore' heads a 340-metre long complex of buildings on the main road linking the port to the city centre. The entire building is clad with stainless steel.

The stainless steel clad rooflight admits daylight into the largely windowless exhibition hall below.

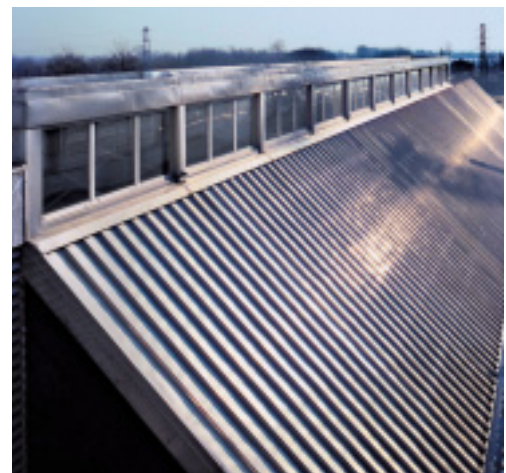

**Institute building at the University of Liège,
Belgium**

Client:
University of Liège
Architects:
Bureau d'études Greisch, Liège

The Institute of Engineering and Construction is located on a campus to the southwest of the town of Liège. The six new building sections are arranged either side of a campus road that slopes down through the hilly site. Care was taken to retain the mature trees.

The choice of a single material for roof and façade enhances the technical character of the building.



Photos: Jean-Luc Deru, DAYLIGHT s.p.r.l., Liège



Originally the roofs and façades of the new buildings were intended to be in copper, in line with the other buildings on campus. But in the end the choice fell on stainless steel because of its lower costs, longevity, corrosion-resistance and not least its high-tech look. The details already worked out for copper cladding were adopted almost unchanged for stainless steel.

The sheet metal strips, mill-finished and precisely 535 mm in width, to fit in with the building's design grid, continue from the façade up onto the roof. The long curving

roof sections are made of continuous strips of stainless steel overhanging slightly to cater for any temperature-related changes in length. On the façades the tensions generated when folding the standing seams gave rise to gentle undulations on the surface. The resulting, irregular light effects and reflections from the surroundings inject great vitality into the clear, ordered lines of the façade.

The 'Documentation Centre' with its glass façades forms the core of the complex, between the stainless steel clad offices and laboratories.

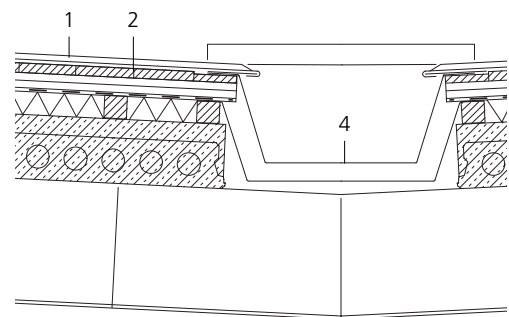
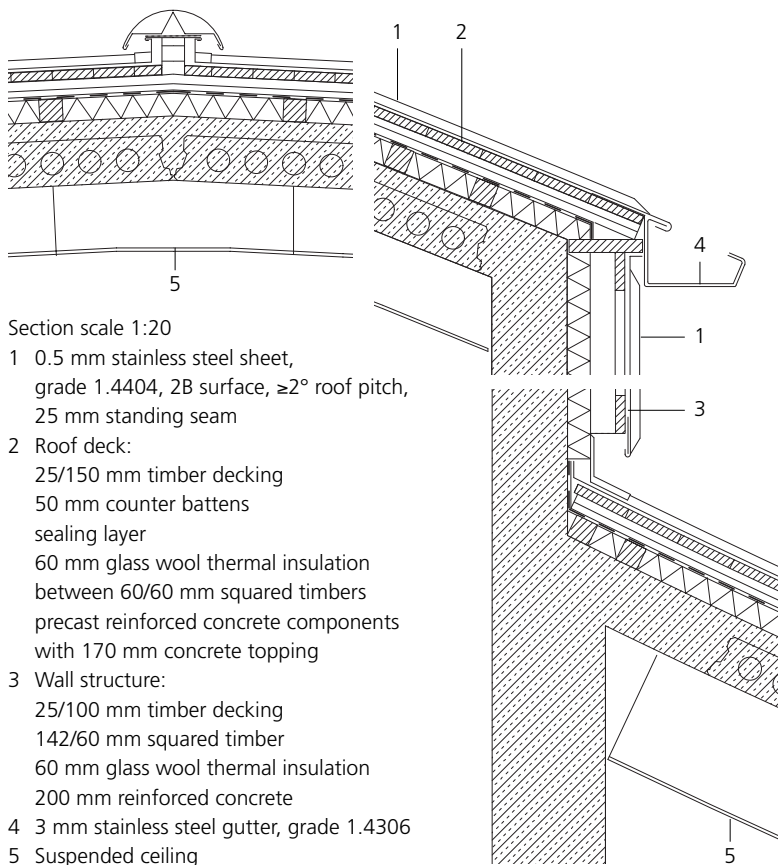

Administration and Commercial



Photo: Florian Holzherr, Munich

All external surfaces – ground, walls and roofs – are covered with a skin of stainless steel.

Administration building in Reutlingen, Germany

Client:
Verband der Metall- und Elektroindustrie
Baden Württemberg e.V., Stuttgart
Architects:
Allmann Sattler Wappner, Munich

The regional offices of Germany's metal and electrical industry association are housed in these three buildings close to the centre of Reutlingen. The immediate neighbourhood is dominated by late 19th-century buildings, up to 15 m wide, rendered or with fair-faced masonry, and with gable roofs. The three new buildings take up this scale and typology, but, with their stainless steel skin, completely reinterpret the theme of 'villa with garden'. Stainless steel panels with cut-out floral designs are used as paving all around the blocks, and continue up 3 m onto the façades at ground floor level. Above this base level, the roofs and façades are clad with bead-blasted stainless steel that gives a very homogeneous look.

Ground plan
scale 1:750

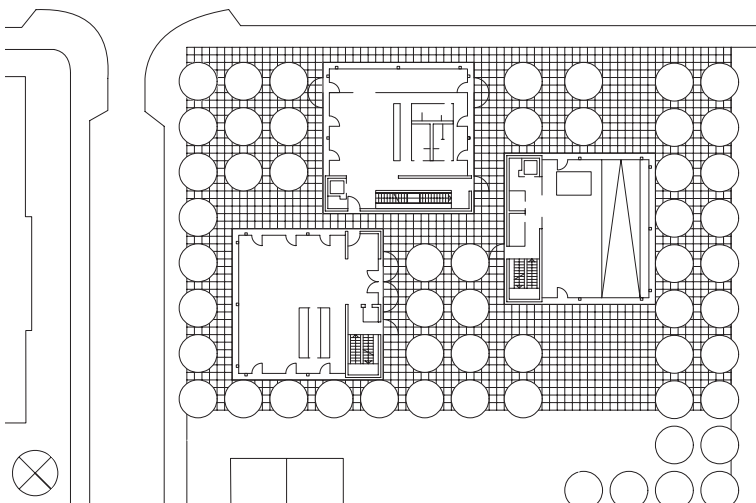

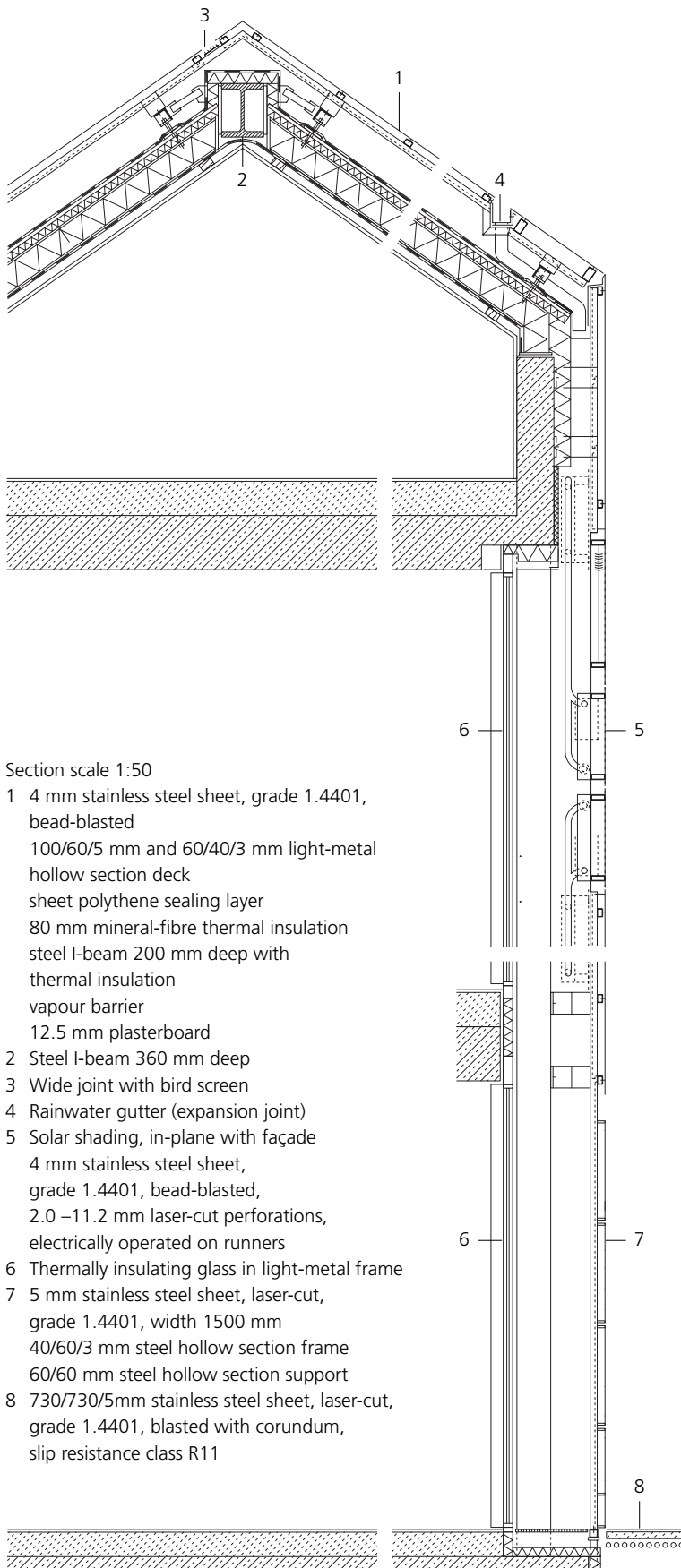

Section scale 1:50

- 1 4 mm stainless steel sheet, grade 1.4401, bead-blasted
100/60/5 mm and 60/40/3 mm light-metal hollow section deck
sheet polythene sealing layer
80 mm mineral-fibre thermal insulation
steel I-beam 200 mm deep with thermal insulation
vapour barrier
12.5 mm plasterboard
- 2 Steel I-beam 360 mm deep
- 3 Wide joint with bird screen
- 4 Rainwater gutter (expansion joint)
- 5 Solar shading, in-plane with façade
4 mm stainless steel sheet, grade 1.4401, bead-blasted, 2.0–11.2 mm laser-cut perforations, electrically operated on runners
- 6 Thermally insulating glass in light-metal frame
- 7 5 mm stainless steel sheet, laser-cut, grade 1.4401, width 1500 mm
40/60/3 mm steel hollow section frame
60/60 mm steel hollow section support
- 8 730/730/5 mm stainless steel sheet, laser-cut, grade 1.4401, blasted with corundum, slip resistance class R11

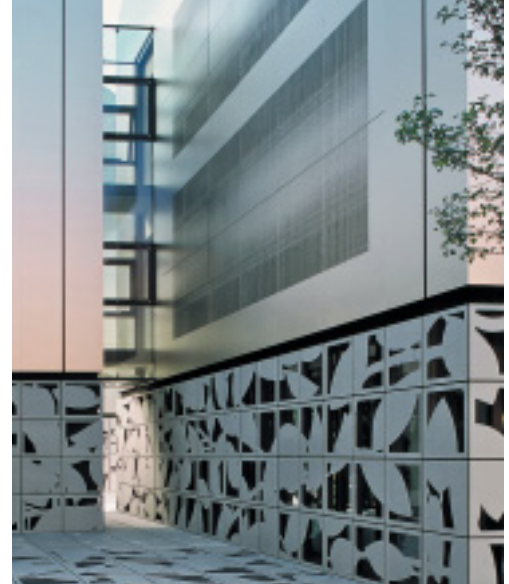

The areas open to the public are located on the ground floor behind the three-metre high decorative stainless steel cladding.

Photos: Jens Passoth, Berlin (top), Florian Holzherr, Munich (bottom)





Stainless steel blinds with laser-cut perforations act as a sun screen in front of the windows, fitting flush with the façade.

Photos: Bernhard Müller, Reutlingen (top)
Florian Holzherr, Munich (bottom)

The even stainless steel cladding of 4 mm thick sheets with a bead-blasted finish is fitted in front of the thermally insulated concrete wall and the windows with thermally insulating glass. The vertical edges of the panels are laser-cut, and designed to be fitted

to the frame beneath via non-expansion screw connections. All the corners of the building are mitre-cut to give the illusion of a jointless surface. A few larger joints are incorporated, to cater for any temperature-related length changes in the material.

The window openings are shaded by electrically operated stainless steel panels with laser-cut perforations of between 2.0 and 11.2 mm. When closed these panels fit flush with the façade; when opened they move upwards and downwards behind the façade.

The entrances are integrated in the continuously patterned, 5 mm thick stainless steel cladding decorating the ground floor level. Outside office hours these entrances are barely perceptible; only when the doors are opened, creating a gap in the pattern, are they recognised for what they are. On the ground outside, square stainless steel panels, 5 mm and 8 mm thick, are used as pavers. Each of the 3,164 panels is different, fitting together to form an overall pattern.



The electrically operated sun screens close smoothly to form a seamless stainless steel skin.



Advertising agency in Klaus, Austria

Client:
 Montfort Werbung Ges.m.b.H., Klaus
 Architect:
 Oskar Leo Kaufmann, Dornbirn

In this project to build an extensively glazed, elevated office facility on the edge of the town of Klaus, it was decided to provide additional storage space in the shape of a 'garden house'. As in the office interiors, stainless steel also features strongly in this structure. Its monolithic appearance is achieved through cladding the entire volume in the same material. The stainless steel cladding panels are fixed to aluminium sections on top of a box of veneered laminated timber panels giving the structural strength; this box is covered entirely with a bonded layer of waterproof seal. All the corners on the outer skin are finished with very small open joints.

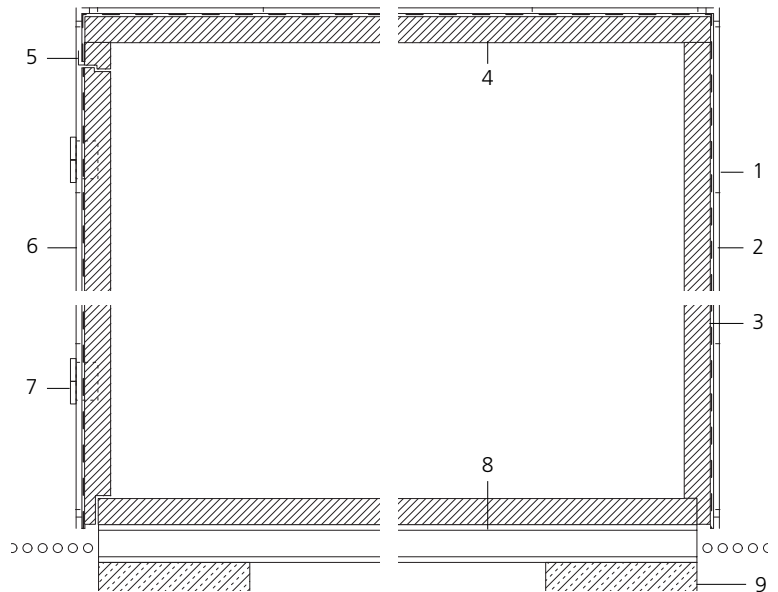

Section scale 1:20

- 1 1 mm stainless steel sheet, grade 1.4301, ground finish
- 2 15/40 mm aluminium hollow section
- 3 Sealing layer
- 4 69 mm veneered laminated timber
- 5 Channel-section aluminium gutter
- 6 Door leaf
- 7 Stainless steel door hinge
- 8 Galvanised steel I-beam, 100 mm deep
- 9 400/400/200 mm precast reinforced concrete foundation block

This prefabricated wooden box, clad entirely in stainless steel, extends the storage facilities of the main building.

Photo: Adolf Bereuter, Lauterach

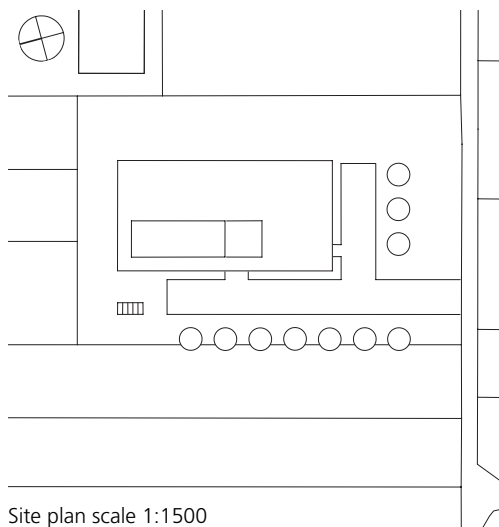

Site plan scale 1:1500

Office building in London, England

Client:
London Serviced Offices Ltd., London
Architect:
Satellite Design Workshop, London

The unusual shape of this building, erected on a gap site on King's Cross Road, is explained by the requirement not to block light to the west window of the adjacent Welsh Chapel. As a result the new building is designed like an extension to the adjacent

The gap site is bordered on one side by a Welsh Chapel and on the other by an old Victorian brick building.



office building, leaving a small courtyard and entrance on the side next to the church. The steel frame of the building is clad with a non-ventilated stainless steel skin that continues up over the façades onto the roof. Two types of seam are used to join the sheets: 25 mm high standing seams running diagonally across the roof and the street façade; and horizontal welded seams on the courtyard side. This skin is affixed to insulating panels that are attached directly to horizontal façade supports between the columns in the building's frame. Also affixed to these panels is the interior cladding. Prefabrication of the components shortened the build time on this narrow site. Horizontal bands of windows fitted flush with the façade maximise the level of natural daylight penetrating into the offices.

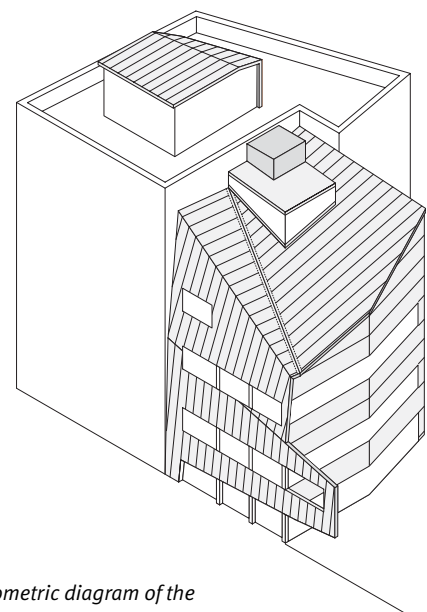

Isometric diagram of the stainless steel cladding.

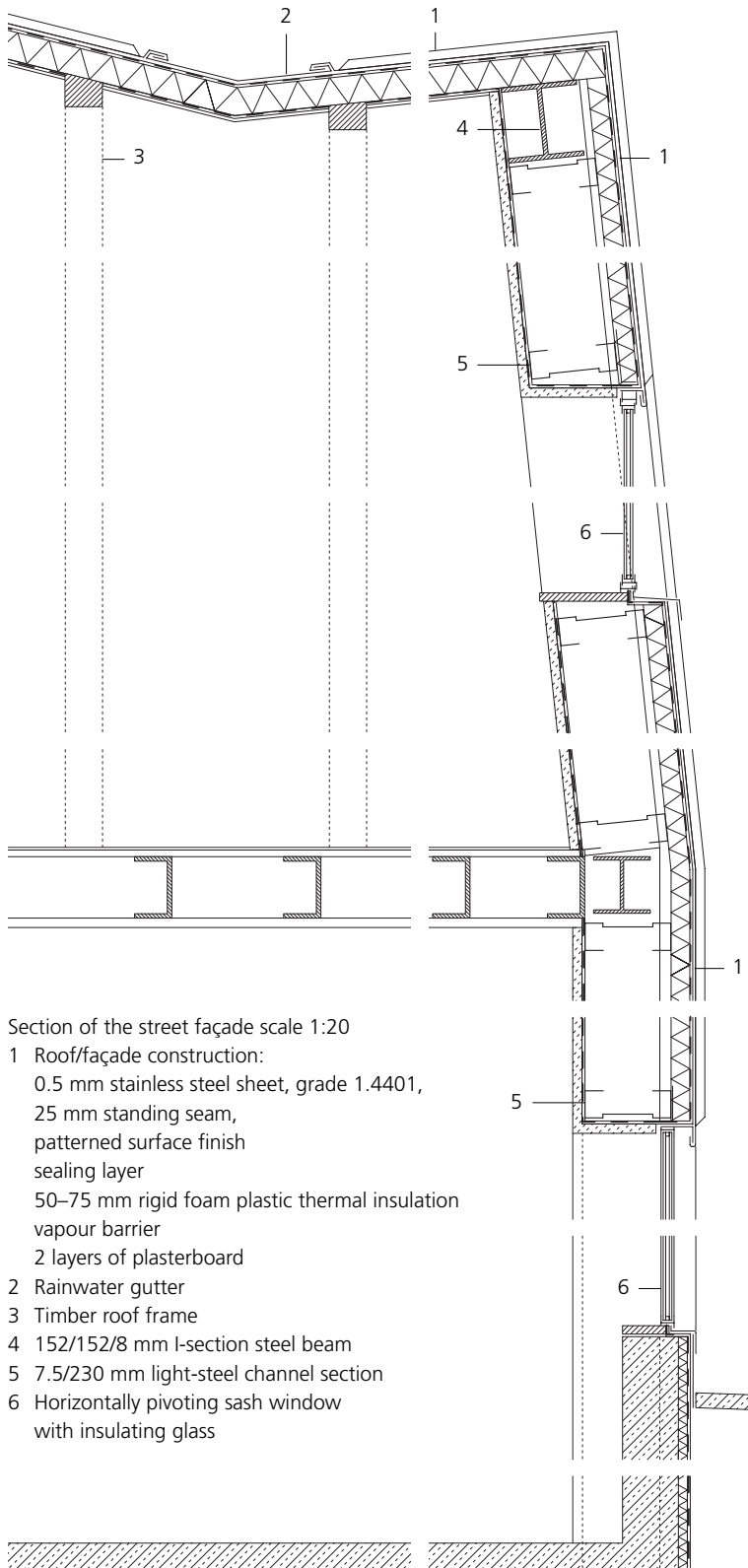

Section of the street façade scale 1:20

- 1 Roof/façade construction:
0.5 mm stainless steel sheet, grade 1.4401,
25 mm standing seam,
patterned surface finish
sealing layer
50–75 mm rigid foam plastic thermal insulation
vapour barrier
2 layers of plasterboard
- 2 Rainwater gutter
- 3 Timber roof frame
- 4 152/152/8 mm I-section steel beam
- 5 7.5/230 mm light-steel channel section
- 6 Horizontally pivoting sash window
with insulating glass



Photos: Nicholas Kane/Arcaid, Kingston upon Thames, England

On the street side, the standing seams run diagonally across the stainless steel façade.





The stainless steel mesh provides the desired solar shading without impairing the panoramic view. It also gives rise to interesting moiré effects.

'Rathausgalerie' in Innsbruck, Austria

Client:
Rathauspassage Ges.m.b.H., Innsbruck
Architects:
Dominique Perrault, Paris in cooperation
with RPM Rolf Reichert, Munich
Achammer, Tritthart & Partner, Innsbruck

The 'Rathausgalerie' is a new complex in the centre of Innsbruck, near the city hall. It comprises a hotel, a shopping arcade, restaurants and green spaces and forms a link between existing local authority facilities. A distinctive feature of the outer face of the complex is the use of stainless steel mesh. On the façade of the hotel, horizontally sliding panels of stainless steel mesh act as solar shading. Above the glass roofs of the shopping arcade and the council chamber is a superstructure covered with tensioned panels of mesh seamlessly continuing around the top of the façade onto the roof. Because of its own weight and the considerable snow and wind loading experienced in this region, the stainless steel skin is tightly pretensioned. Pressure springs at the lower fixing point keep the skin taut.

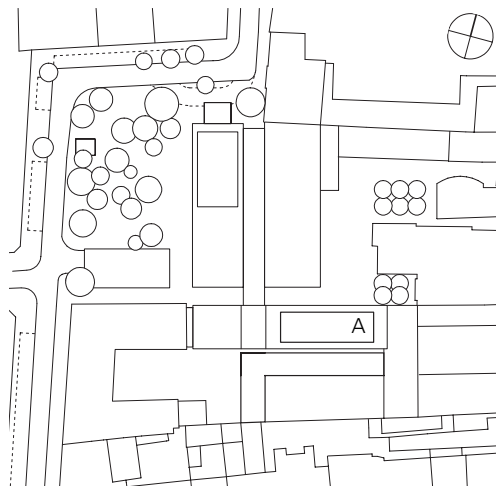

Site plan
scale 1:2500
A Council chamber

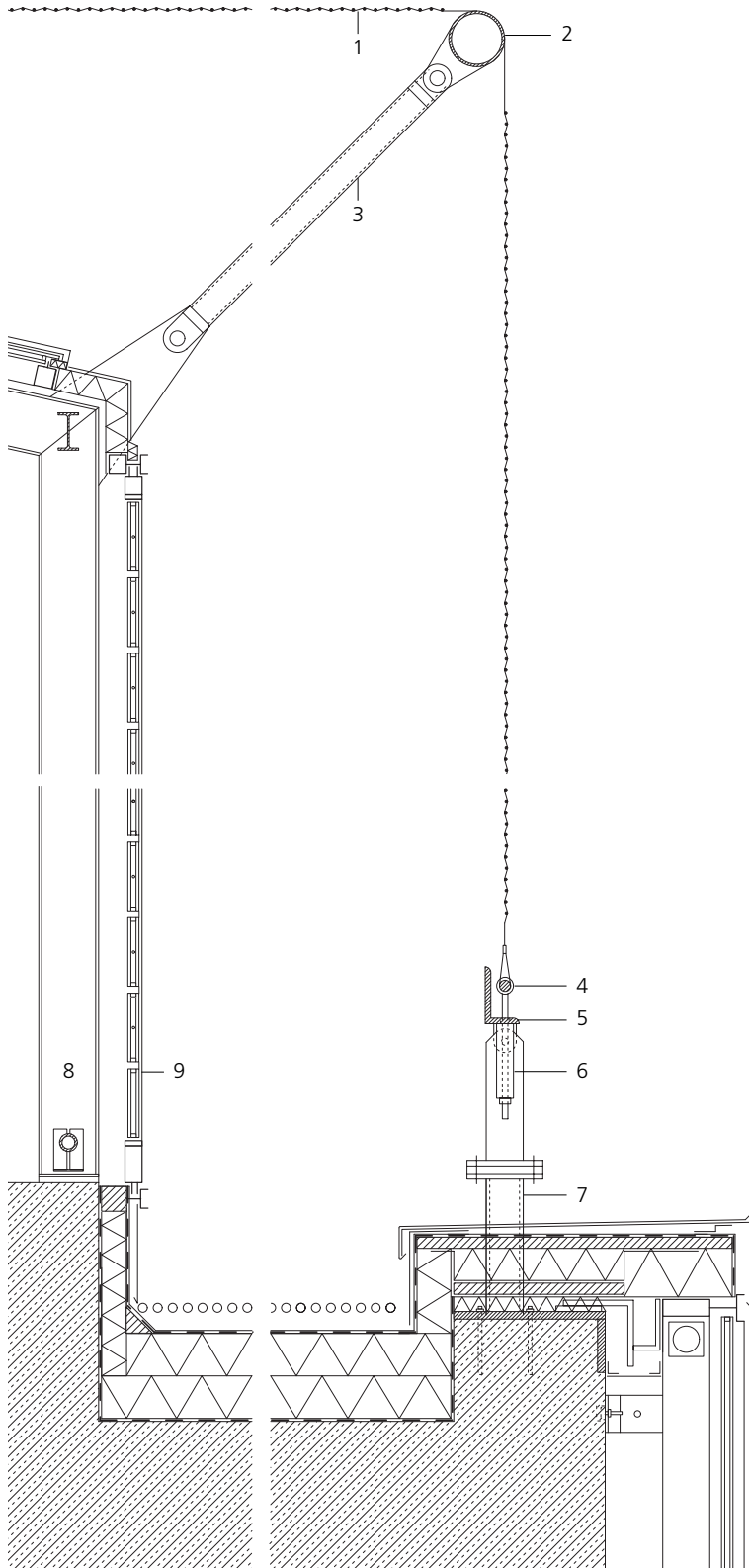

Section scale 1:20

- 1 Stainless steel mesh, $b=1330$ mm
- 2 115 mm dia. steel tube
- 3 80 mm dia. compression bar
- 4 Mesh fixing:
30 mm dia. stainless steel bar,
wound in to lower edge of mesh
stainless steel eye bolts
- 5 Longitudinal girder, 150/90 mm steel angle section
- 6 Pressure spring
- 7 Steel hollow section 100/100/10 mm
- 8 Steel I-beam 160 mm deep
- 9 Aluminium window frame with insulating glass

Strong pressure springs on the lower edge hold the mesh constantly taut, to counteract the self weight of the steel and heavy snow and wind loading.

Photos:
Roland Halbe, Stuttgart



Sports Facilities

Bergisel ski jump, Innsbruck, Austria

Client:
Bergisel Betriebsgesellschaft, Innsbruck
Architects:
Zaha Hadid Architects, London

The ski jump on Bergisel, a mountain overlooking Innsbruck on the south side, consists of two parts, each different in form and

material: a tower of reinforced concrete and the jump itself with a curving, steel-framed structure at the top of tower, clad with stainless steel. This top section, which is a prominent feature for miles around, houses a café and viewing platform. Designed as a steel space frame, it wraps itself around the exposed concrete tower and merges into the suspended approach ramp. The façade of the tower head is clad with stainless steel sheet with a cold-rolled finish that reduces the inherent stresses in the material and

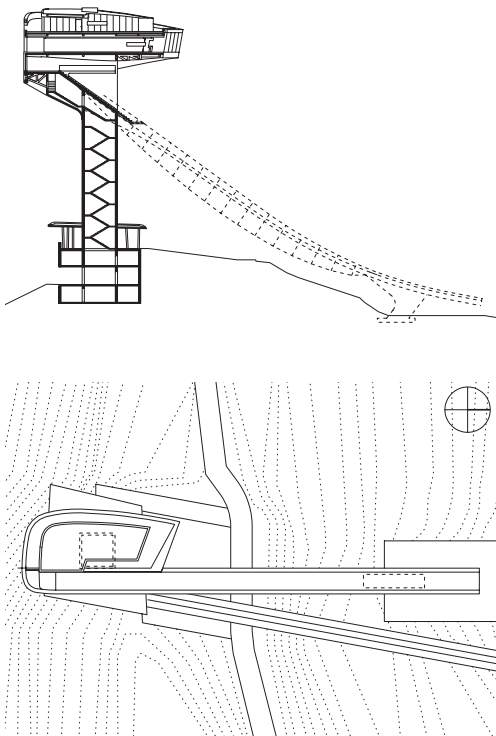

Section · Site plan
scale 1:1500



Photos:
Roland Halbe, Stuttgart

thus enables optimum adaptation to the complex geometry of the building volume. Furthermore its fine surface structure gives enhanced resistance to dents and scratches and contributes to the smooth visual impression. The surface reacts to changing light moods, reflecting the changing colours of the surroundings.

The café and viewing platform on Bergisel ski jump add to the functionality of this sporting facility and also make it a popular tourist attraction.

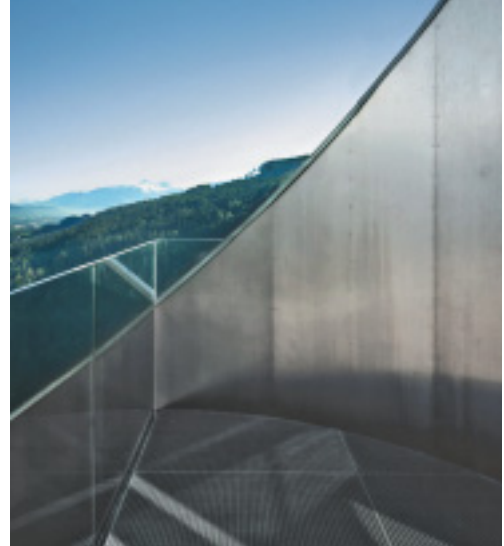

Section scale 1:20

- 1 1 mm stainless steel sheet, grade 1.4301
patterned surface finish
stainless steel rivets a=150 mm
- 2 40 mm trapezoid sheet
- 3 60/60/3 mm steel hollow section
- 4 3 mm steel sheet, double folded
- 5 80/40/5 mm steel angle
- 6 60/60/5 mm steel angle
- 7 10 mm dia. threaded rod for assembly
- 8 120/60/10 mm steel angle section
- 9 35/35/2 mm steel hollow section
- 10 30/60/30/4 mm steel channel section
- 11 200/300/15 mm steel RHS

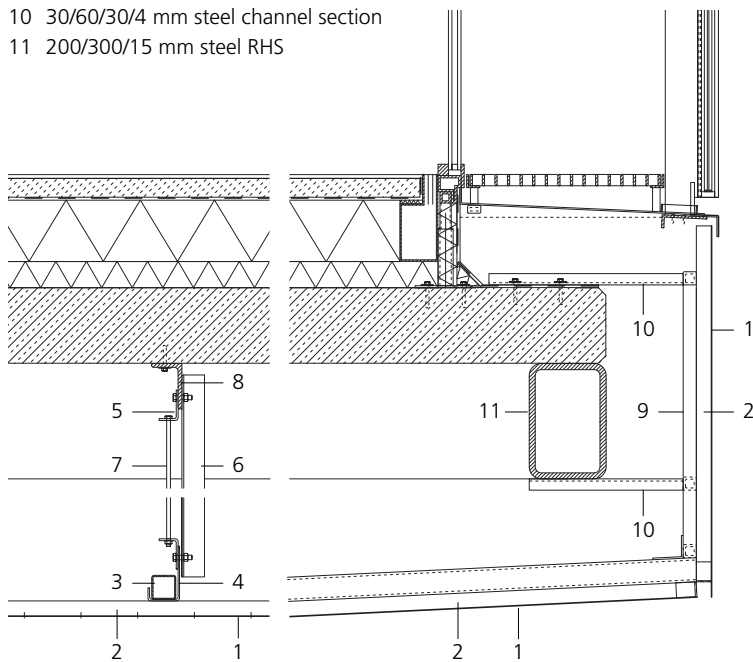

The 1 mm thick stainless steel panels are blind-riveted to the support frame below.

Technical Installations



The linear structure of the inflated barrier is visible in the water between the two control centres.

Photos: Vincent Jannink ANP/dpa (top), Rob 't Hart, Rotterdam (bottom)

Control centres for a flood barrier, Kampen, Netherlands

Client:

HBW Gouda

Architects:

Zwarts & Jansma Architecten, Amsterdam

The flood barrier at Ramspol near Kampen is part of a series of measures designed to give protection against high tides in the IJsselmeer. Instead of just raising the height of existing dikes, a new concept was developed.

This involves the use of inflatable plastic cushions in the barrier system; when water levels rise, the cushions are filled with air and water. The construction is divided into three 80-metre long sections that lie out of sight on the river bed when water levels are normal. At high tide the cushions can be filled to a height of 8 m and a depth of 13 m. The entire installation forms a straight line in the landscape. Identical buildings at either end of the line house control systems for the pump mechanism. Sitting on a concrete base, these structures unfold in five ellipti-

Site plan
scale 1:10000

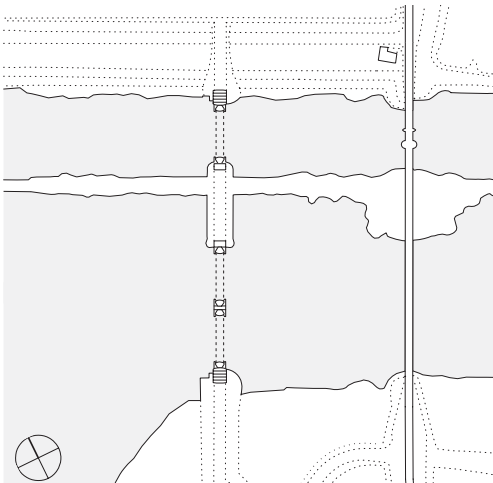



cally shaped, steel-clad shells that increase in diameter towards the water.

Because of the coastal location, the roofs of the two buildings are designed for high wind loads. Elliptically shaped steel sections support a deck of trapezoid sheet. The building skin consists of 60 cm wide sheets of stainless steel with a cold-rolled matt surface finish. Diffuse reflections of light and of the surroundings turn the buildings into an integral part of the landscape.

Photos: Rob 't Hart, Rotterdam

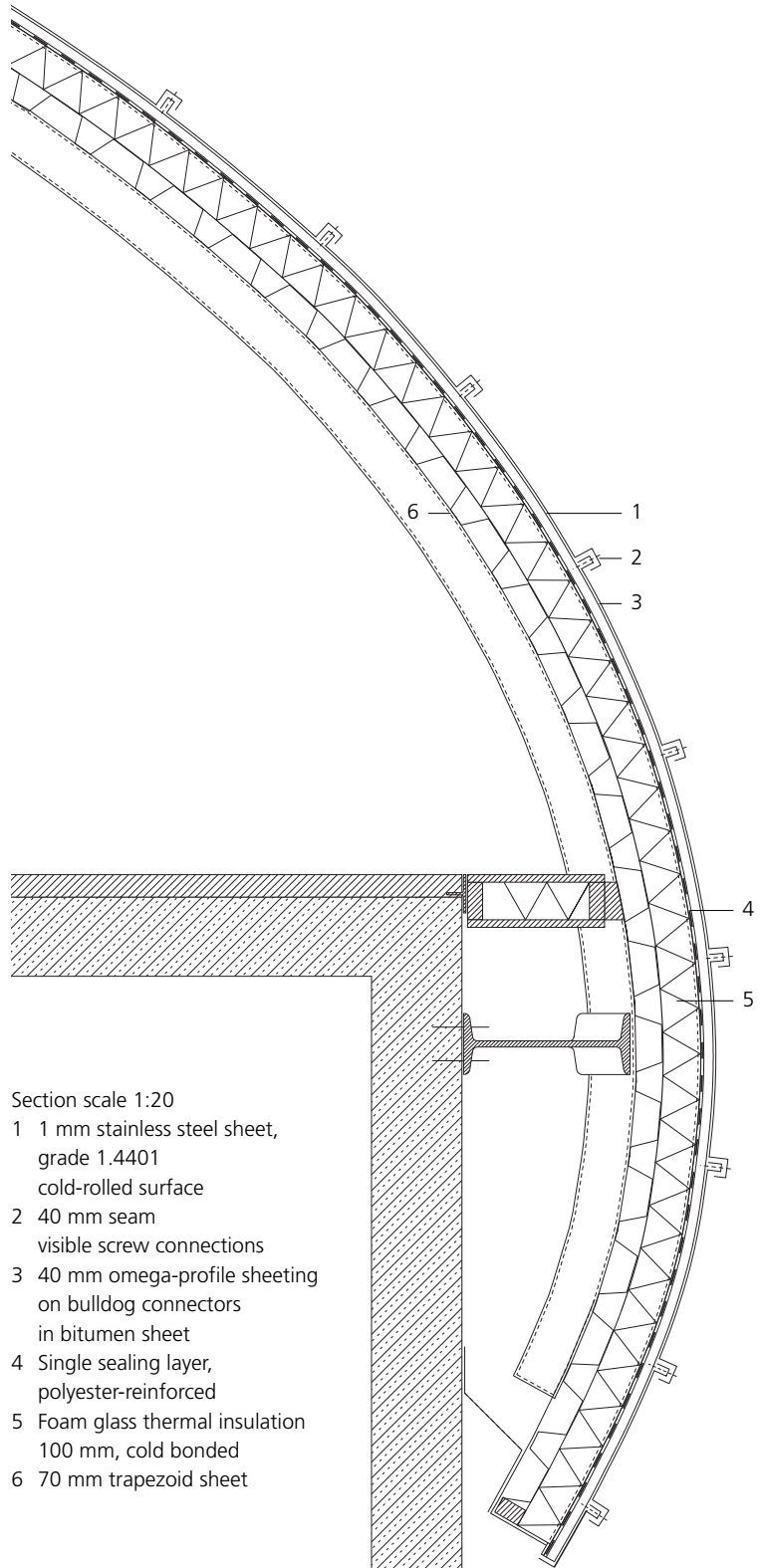
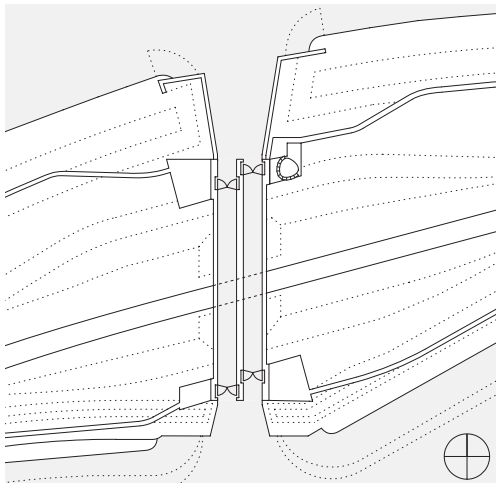



Photo: Zwarts & Jansma
Architecten, Amsterdam

**Control tower for a lock, Enkhuizen,
Netherlands**

Client:
Bouwdienst Rijkswaterstaat, Utrecht
Architects:
Zwarts & Jansma Architecten, Amsterdam



Site plan
scale 1:5000

A new lock was built on the west side of Houtrib Dike, replacing a bascule bridge which could no longer cope with the volume of traffic passing over it. Serious delays had resulted for road and water traffic. The motorway between Enkhuizen and Lelystad now runs unhindered below the new aqueduct. The lock's control tower, easily visible from afar, rises up above the two parallel, 120-m long lock chambers made of concrete. It consists of a concrete base section, housing all ancillary rooms, and a separate control room above, reached via a glazed staircase. The free form of this control room seems to float above the solid structure of the bridge, its glossy surfaces further enhancing the impression. Flat, polygonal panels of stainless steel form the façade, while rounded panels continue the cladding on the visible underside. The panels are fixed along the vertical joints via pressed battens screwed to the frame beneath.

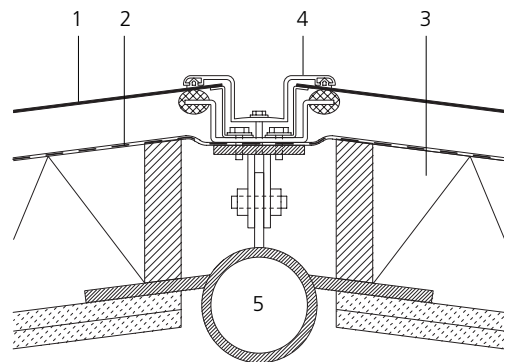

Section vertical joint scale 1:5

- 1 1.5 mm stainless steel sheet, grade 1.4401
- 2 Sealing layer
- 3 100 mm insulation
- 4 Aluminium cover strip
- 5 76.1 dia./5 mm tubular steel

ISBN 2-87997-085-7